

Gold Twitter Digital Servo Drive Installation Guide CAN and EtherCAT

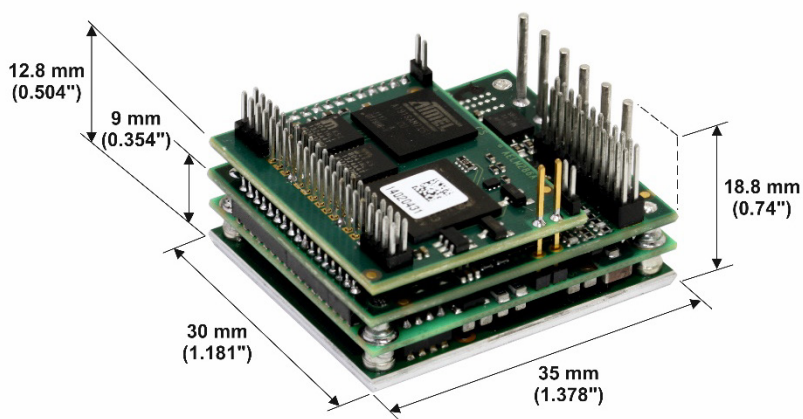
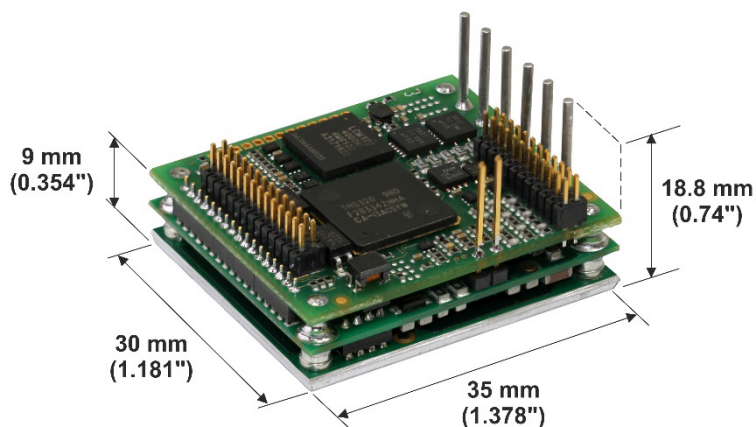

Notice

This guide is delivered subject to the following conditions and restrictions:

- This guide contains proprietary information belonging to Elmo Motion Control Ltd. Such information is supplied solely for the purpose of assisting users of the Gold Twitter servo drive in its installation.
- The text and graphics included in this manual are for the purpose of illustration and reference only. The specifications on which they are based are subject to change without notice.
- Information in this document is subject to change without notice.

Document no. MAN-G-TWI (Ver. 2.011)
 Copyright © 2023
 Elmo Motion Control Ltd.
 All rights reserved.

Catalog Number

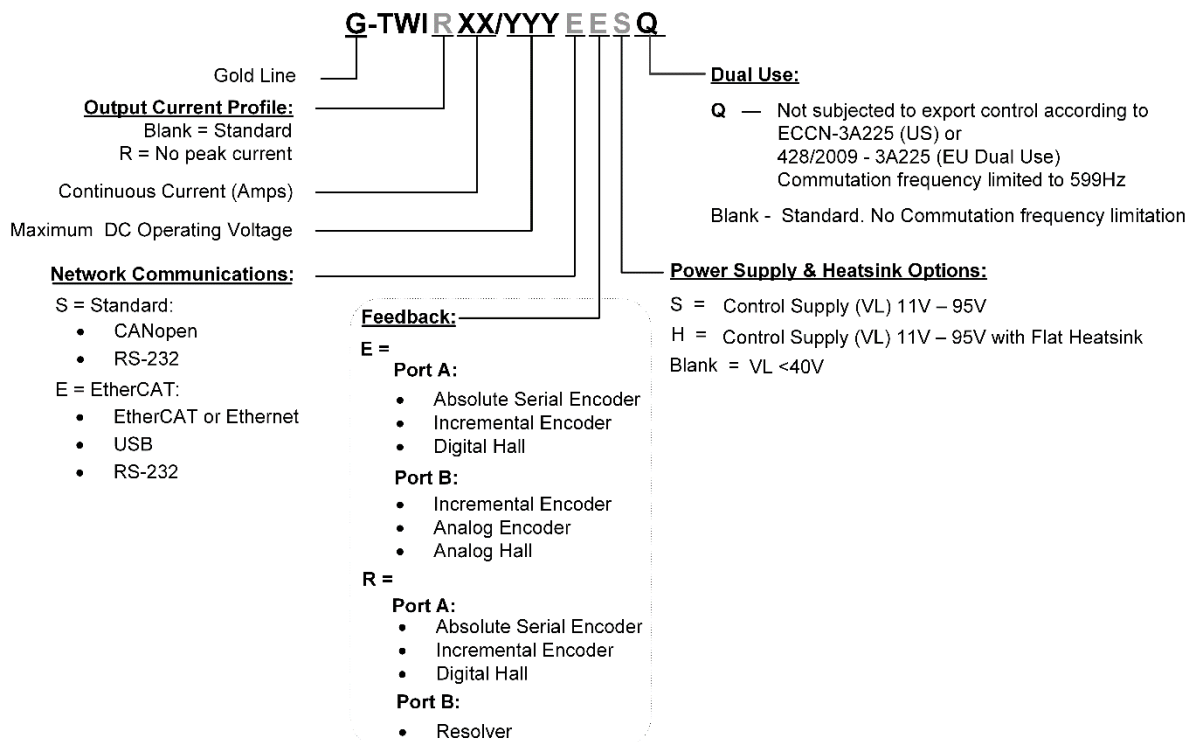

To order the accessories refer to the Chapter 13: Accessories.

Revision History

| Version | Date |
|----------------|-------------|
| Ver. 1.004 | Oct 2014 |
| Ver. 1.005 | Nov 2014 |
| Ver. 1.006 | Nov 2014 |
| Ver. 1.007 | Dec 2014 |
| Ver. 1.008 | Jan 2015 |
| Ver. 1.009 | Jan 2015 |
| Ver. 1.010 | Feb 2015 |
| Ver. 1.011 | Mar 2015 |
| Ver. 1.012 | Mar 2015 |
| Ver. 1.013 | May 2015 |
| Ver. 1.014 | June 2015 |
| Ver. 1.015 | Dec 2015 |
| Ver. 1.016 | Mar 2016 |
| Ver. 1.017 | Sep 2016 |
| Ver. 1.018 | Oct 2016 |
| Ver. 1.019 | Jan 2017 |
| Ver. 1.020 | Apr 2017 |
| Ver. 1.021 | Apr 2017 |
| Ver. 1.022 | Aug 2017 |
| Ver. 1.023 | Aug 2017 |
| Ver. 1.024 | Oct 2018 |
| Ver. 2.000 | Nov 2018 |
| Ver. 2.002 | Oct 2019 |
| Ver. 2.003 | Jan 2020 |
| Ver. 2.004 | Apr 2020 |
| Ver. 2.005 | Dec 2020 |
| Ver. 2.006 | Sept 2021 |
| Ver. 2.007 | Oct 2021 |
| Ver. 2.008 | Nov 2021 |
| Ver. 2.009 | Apr 2022 |
| Ver. 2.010 | Sept 2022 |
| Ver. 2.011 | Jan 2023 |

| | |
|--|-----------|
| Chapter 1: This Installation Guide | 7 |
| Chapter 2: Safety Information | 7 |
| 2.1. Warnings | 8 |
| 2.2. Cautions..... | 8 |
| 2.3. Warranty Information | 8 |
| Chapter 3: Product Description | 9 |
| Chapter 4: Technical Information | 10 |
| 4.1. Physical Specifications..... | 10 |
| 4.2. 60V and 100V Models Technical Data..... | 11 |
| 4.3. 200V Models Technical Data..... | 11 |
| 4.4. R Type Technical Data | 12 |
| 4.5. Control Supply Input Voltage (VL)..... | 13 |
| 4.6. Product Features | 13 |
| 4.7. Environmental Conditions..... | 14 |
| Chapter 5: Standards and Certifications | 15 |
| 5.1. Functional Safety..... | 15 |
| 5.2. Electrical Safety | 15 |
| 5.3. Electromagnetic Compatibility..... | 15 |
| 5.4. Environmental | 16 |
| 5.5. Other Compliant Standards..... | 16 |
| 5.6. CE Declaration | 16 |
| 5.7. Dual Use | 16 |
| Chapter 6: Unpacking the Drive Components | 17 |
| Chapter 7: Mounting the Gold Twitter | 18 |
| 7.1. Mounting the Optional Accessories Heat Sinks | 20 |
| 7.2. Mounting Gold Twitter to an External Heatsink | 22 |
| Chapter 8: Integrating the Gold Twitter on a PCB | 23 |
| 8.1. Power Returns (PR) | 23 |
| 8.2. COMRET..... | 23 |
| 8.3. Earth Connection (PE) | 23 |
| 8.4. Power Return (PR), Common Return (COMRET) and Earth Connections (PE)..... | 24 |
| 8.5. Logic and Control Cabling and Wiring | 25 |
| 8.5.1. Feedback ports, VL, RS232, USB, Analog Input | 25 |

| | | |
|--------------------|---|-----------|
| 8.5.2. | Digital Inputs/Outputs, STO | 25 |
| 8.5.3. | EtherCAT or CAN Communication..... | 25 |
| 8.5.4. | COMRET to PE Connection | 25 |
| 8.6. | Power Conductors PCB layout..... | 26 |
| Chapter 9: | Wiring | 27 |
| 9.1. | Wiring Legend | 27 |
| 9.2. | The Gold Twitter Connection Diagram..... | 28 |
| Chapter 10: | Connections | 30 |
| 10.1. | Motor Power | 33 |
| 10.1.1. | Motor Power Connections | 34 |
| 10.2. | Main Power and Control Connector | 35 |
| 10.2.1. | Main Power | 35 |
| 10.2.2. | Control Supply | 36 |
| 10.2.3. | Control Supply Connections for G-TWIXXX/YYYYZ(Blank)..... | 37 |
| 10.2.3.1. | Dual Power Supply Topology..... | 37 |
| 10.2.3.2. | Single Power Supply Topology (VP+ < 40VDC) | 39 |
| 10.2.4. | Control Supply Connections for G-TWIXXX/YYYYZS or H | 42 |
| 10.2.4.1. | Dual Power Supply Topology..... | 42 |
| 10.2.4.2. | Single Power Supply Topology (VP+ < 95VDC) | 44 |
| 10.3. | Feedback Connector FDB | 47 |
| 10.3.1. | Port A..... | 49 |
| 10.3.1.1. | Incremental Encoder | 49 |
| 10.3.1.2. | Absolute Serial Encoder | 50 |
| 10.3.1.3. | Hall Sensors | 52 |
| 10.3.2. | Port B..... | 53 |
| 10.3.2.1. | Incremental Encoder | 53 |
| 10.3.2.2. | Interpolated Analog Encoder | 54 |
| 10.3.2.3. | Resolver | 55 |
| 10.3.3. | Port C – Emulated Encoder Output (FDB) | 56 |
| 10.4. | Main Connector (MAIN) | 57 |
| 10.4.1. | Digital Inputs | 60 |
| 10.4.2. | Digital Outputs..... | 62 |
| 10.4.3. | STO (Safe Torque Off)..... | 65 |
| 10.4.4. | Analog Input | 66 |
| 10.4.5. | CAN Option..... | 67 |
| 10.4.5.1. | Interface | 67 |

| | | |
|--------------------|--|-----------|
| 10.4.5.2. | CAN Layout | 68 |
| 10.4.6. | RS232 | 69 |
| 10.5. | EtherCAT Module | 71 |
| 10.5.1. | EtherCAT Module Connectors | 71 |
| 10.5.1.1. | ECT2 connector..... | 71 |
| 10.5.1.2. | ECT1 connector..... | 72 |
| 10.5.1.3. | ECT3 Connector | 72 |
| 10.5.1.4. | 3.3V Connector..... | 72 |
| 10.5.2. | EtherCAT Communication | 73 |
| 10.5.3. | USB 2.0 Communication (for EtherCAT model only)..... | 74 |
| Chapter 11: | Powering Up..... | 75 |
| 11.1. | Initializing the System | 75 |
| 11.2. | Heat Dissipation | 75 |
| 11.2.1. | Heat Dissipation Data | 75 |
| 11.2.2. | How to Use the Chart | 78 |
| Chapter 12: | Dimensions | 79 |
| 12.1. | EtherCAT without Heatsink..... | 79 |
| 12.2. | EtherCAT with Heatsink..... | 80 |
| 12.3. | CAN without Heatsink | 81 |
| 12.4. | CAN with Heatsink..... | 82 |
| Chapter 13: | Accessories..... | 83 |
| 13.1. | Accessories Heat Sink Dimensions | 84 |



Chapter 1: This Installation Guide

This installation Guide details the technical data, pinouts, and power connectivity of the Gold Twitter. For a comprehensive detailed description of the functions and connections of the drive, refer to the Gold Board Level Module Hardware Manual.

Chapter 2: Safety Information

In order to achieve the optimum, safe operation of the Gold Twitter, it is imperative that you implement the safety procedures included in this installation guide. This information is provided to protect you and to keep your work area safe when operating the Gold Twitter and accompanying equipment.

Please read this chapter carefully before you begin the installation process.

Before you start, ensure that all system components are connected to earth ground. Electrical safety is provided through a low-resistance earth connection.

Only qualified personnel may install, adjust, maintain and repair the servo drive. A qualified person has the knowledge and authorization to perform tasks such as transporting, assembling, installing, commissioning and operating motors.

The Gold Twitter contains electrostatic-sensitive components that can be damaged if handled incorrectly. To prevent any electrostatic damage, avoid contact with highly insulating materials, such as plastic film and synthetic fabrics. Place the product on a conductive surface and ground yourself in order to discharge any possible static electricity build-up.

To avoid any potential hazards that may cause severe personal injury or damage to the product during operation, keep all covers and cabinet doors shut.

The following safety symbols are used in this and all Elmo Motion Control manuals:



Warning:

This information is needed to avoid a safety hazard, which might cause bodily injury or death as a result of incorrect operation.



Caution:

This information is necessary to prevent bodily injury, damage to the product or to other equipment.



Important:

Identifies information that is critical for successful application and understanding of the product.



2.1. Warnings

- To avoid electric arcing and hazards to personnel and electrical contacts, never connect/disconnect the servo drive while the power source is on.
- Power cables can carry a high voltage, even when the motor is not in motion. Disconnect the Gold Twitter from all voltage sources before servicing.
- The high voltage products within the Gold Line range contain grounding conduits for electric current protection. Any disruption to these conduits may cause the instrument to become hot (live) and dangerous.
- After shutting off the power and removing the power source from your equipment, wait at least 3 minutes before touching or disconnecting parts of the equipment that are normally loaded with electrical charges (such as capacitors or contacts). Measuring the electrical contact points with a meter, before touching the equipment, is recommended.



2.2. Cautions

- The maximum DC power supply connected to the instrument must comply with the parameters outlined in this guide.
- When connecting the Gold Twitter to an approved control supply, connect it through a line that is separated from hazardous live voltages using reinforced or double insulation in accordance with approved safety standards.
- Before switching on the Gold Twitter, verify that all safety precautions have been observed and that the installation procedures in this manual have been followed.
- Make sure that the Safe Torque Off is operational

2.3. Warranty Information

The products covered in this manual are warranted to be free of defects in material and workmanship and conform to the specifications stated either within this document or in the product catalog description. All Elmo drives are warranted for a period of 12 months from the date of shipment. No other warranties, expressed or implied — and including a warranty of merchantability and fitness for a particular purpose — extend beyond this warranty.



Chapter 3: Product Description

The Gold Twitter is an advanced high power density servo drive, delivering up to **5.6 kW power** in a 12.6 cm³ (0.769 in³) compact package (35 x 30 x 11.5 mm or 1.38" x 1.18" x 0.45"). The Gold Twitter is designed to be mounted on a PCB by soldering its pins directly to the PCB.

This advanced, high power density servo drive provides top performance, advanced networking and built-in safety, as well as a fully featured motion controller and local intelligence. Power to the Gold Twitter is provided by a DC power source which is isolated from the Mains. The Gold Twitter can operate with single or dual power supplies. If separation between the main DC power source and a control supply is required, then a control supply (isolated from the Mains) is required.

The drive can operate as a stand-alone device or as part of a multi-axis system in a distributed configuration on a real-time network.

The Gold Twitter drive is easily set up and tuned using the Elmo Application Studio (EASII) software tools. As part of the Gold product line, it is fully programmable with the Elmo motion control language. For more information about software tools refer to the Elmo Application Studio (EASII) User Guide.

The Gold Twitter is available in a variety of models. There are a number of possible options; multiple power rating, various communications, and feedback.

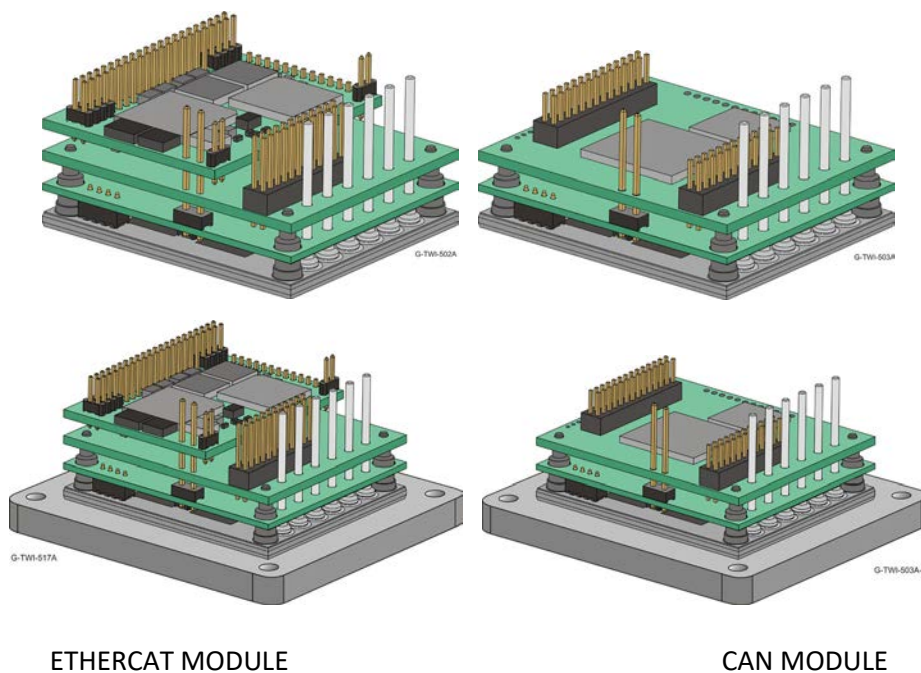

Figure 1: Difference between 3-Tier CAN and 4-Tier EtherCAT modules with/without Heatsink

Within the variety of models offered, the CAN and EtherCAT versions are physically different in that the CAN version has three tiers, whereas the EtherCAT version has four tiers, as shown in Figure 1.

Optionally, where necessary, Elmo offers two external heat sinks (Catalog number: G-TWIHSFINS01, and G-TWIHSFLAT01) which should be ordered separately. Refer to the section 7.1 Mounting the Optional Accessories Heat Sinks for details of installing the heat sinks.



Chapter 4: Technical Information

Note: It should be noted that for all models, the Max Output current is guaranteed for $T_{\text{Heat-Sink}} < 85^{\circ}\text{C}$

4.1. Physical Specifications

| Feature | Units | All Types |
|---|---------|---|
| Weight without Heatsink | g (oz) | EtherCAT Version: 22.2 g (0.78 oz) CAN Version: 18.6 g (0.66 oz) |
| Weight with Heatsink | g (oz) | EtherCAT Version: 43.2 g (1.52 oz) CAN Version: 39.6 g (1.40 oz) |
| EtherCAT Version Dimension without Heatsink | mm (in) | 35 x 30 x 14.4 mm (1.38" x 1.18" x 0.57") |
| CAN Version Dimension without Heatsink | | 35 x 30 x 11.5 mm (1.38" x 1.18" x 0.45") |
| EtherCAT Version Dimension with Heatsink | | 47 x 41.3 x 18.4 mm (1.85" x 1.63" x 0.72") |
| CAN Version Dimension with Heatsink | | 47 x 41.3 x 15.5 mm (1.85" x 1.63" x 0.61") |
| Mounting method | | PCB mount |
| IP | | IP00 |



4.2. 60V and 100V Models Technical Data

| Feature | Units | 30/60 | 1/100 | 3/100 | 6/100 | 10/100 | 15/100 | 25/100 |
|---|-------|-----------------------------|-------|-------|-------|--------|--------|--------|
| Minimum supply voltage | VDC | 8 | 10 | | | | | |
| Nominal supply voltage | VDC | 48 | 85 | | | | | |
| Maximum supply voltage | VDC | 55 | 95 | | | | | |
| Maximum continuous power output | W | 1370 | 80 | 235 | 470 | 800 | 1125 | 2000 |
| Efficiency at rated power (at nominal conditions) | % | > 99 | | | | | | |
| Maximum output voltage | | Up to 96% of DC bus voltage | | | | | | |
| Ic, Amplitude sinusoidal/DC continuous current | A | 30 | 1 | 3 | 6 | 10 | 15 | 25 |
| Sinusoidal continuous RMS current limit (Ic) | A | 21 | 0.7 | 2.1 | 4.2 | 7.1 | 10 | 17.7 |
| Peak current limit | A | 2 x Ic | | | | | | |

Table 1: 60V and 100V Models Technical Data

4.3. 200V Models Technical Data

| Feature | Units | 3/200 | 6/200 | 10/200 |
|---|-------|-----------------------------|-------|--------|
| Minimum supply voltage | VDC | 20 | | |
| Nominal supply voltage | VDC | 170 | | |
| Maximum supply voltage | VDC | 195 | | |
| Maximum continuous power output | W | 485 | 975 | 1650 |
| Efficiency at rated power (at nominal conditions) | % | > 99 | | |
| Maximum output voltage | | Up to 96% of DC bus voltage | | |
| Ic, Amplitude sinusoidal/DC continuous current | A | 3 | 6 | 10 |
| Sinusoidal continuous RMS current limit (Ic) | A | 2.1 | 4.2 | 7.1 |
| Peak current limit | A | 2 x Ic | | |

Table 2: 200V Models Technical Data



4.4. R Type Technical Data

| Feature | Units | R50/60 | R80/80 | R50/100 | R70/100 | R45/150 | R15/200 | R35/200 |
|---|-------|-----------------------------|--------|---------|---------|---------|---------|---------|
| Minimum supply voltage | VDC | 8 | 10 | 10 | 10 | 12 | 20 | 20 |
| Nominal supply voltage | VDC | 48 | 65 | 85 | 85 | 115 | 170 | 170 |
| Maximum supply voltage | VDC | 55 | 75 | 95 | 95 | 135 | 195 | 195 |
| Maximum continuous Electrical power output | kW | 2.3 | 5 | 4.0 | 5.6 | 5 | 2.5 | 5.6 |
| Efficiency at rated power (at nominal conditions) | % | > 99 | | | | | | |
| Maximum output voltage | | Up to 96% of DC bus voltage | | | | | | |
| Amplitude sinusoidal/DC continuous current | A | 50 | 80 | 50 | 70 | 45 | 15 | 35 |
| Sinusoidal continuous RMS current limit (Ic) | A | 35.3 | 56.5 | 35.3 | 49.5 | 32 | 10.6 | 24.7 |

Table 3: R Type Models Technical Data



4.5. Control Supply Input Voltage (VL)

The Control Supply input voltage (VL) must be either SELV or PELV rated.

| Feature | Unit | Details |
|--|------|---------|
| Standard CAN | | |
| Input range for G-TWIXXX/YYYSZ(Blank) | V | 12 – 40 |
| Input range for G-TWIXXX/YYYSZS or H | V | 12 – 95 |
| 24V Control supply input power consumption with encoder up to 200mA@5V | W | <2.5 |
| ETHERCAT | | |
| Input range for G-TWIXXX/YYEYZ(Blank) | V | 14 – 40 |
| Input range for G-TWIXXX/YYEYZS or H | V | 12 – 95 |
| 24V Control supply input power consumption with encoder up to 200mA@5V | W | <4 |

4.6. Product Features

| Main Feature | Details | Presence / No. |
|------------------------------|--|----------------|
| STO | 5V Logic Level, Opto isolated from the Control section | ✓ |
| Digital Input Option | 5V Logic Level (Internally connected to COMRET) | 6 |
| Digital Output Option | 5V logic (Internally connected to COMRET) | 2 |
| | 3.3V logic (Internally connected to COMRET) | 2 |
| Analog Input | Differential ±10V | 1 |
| | Single Ended | 1 |
| Feedback | Standard Port A, B, & C | ✓ |
| Communication Option | USB (only for EtherCAT version) | ✓ |
| | EtherCAT <i>or</i> | ✓ |
| | CAN | ✓ |
| | RS232 TTL level | ✓ |
| | Standard RS232 | ✓ |



4.7. Environmental Conditions

You can guarantee the safe operation of the Gold Twitter by ensuring that it is installed in an appropriate environment. The following table describes the certified environmental conditions for STO of the Gold series servo drives.



Warning: During operation the Gold Twitter becomes hot to the touch (the heatsink and wires may heat up to 92 °C). Care should be taken when handling it.



Caution:

The Gold Twitter dissipates its heat by convection or by conduction. The maximum ambient operating temperature of 50 °C (122°F) must not be exceeded.

| Feature | Details |
|---|---|
| Operating ambient temperature | 0 °C to +50 °C (32 °F to +122 °F) |
| Storage temperature | -40 °C to +85 °C (-40 °F to +185 °F) |
| Maximum non-condensing humidity according to IEC60068-2-78 | 95% |
| Maximum Operating Altitude | 2,000 m (6562 feet) It should be noted that servo drives capable of higher operating altitudes are available on request. |
| Mechanical Shock according to IEC60068-2-27 | 15g / 11ms Half Sine |
| Vibration according to IEC60068-2-6 | 5 Hz ≤ f ≤ 10 Hz: ±10mm 10 Hz ≤ f ≤ 57 Hz: 4G 57 Hz ≤ f ≤ 500 Hz: 5G |



Chapter 5: Standards and Certifications

5.1. Functional Safety

| Standard | Item |
|----------------------------|---|
| IEC 61800-5-2:2017 | Adjustable speed electrical power drive systems – Safety requirements – Functional |
| EN ISO 13849-1:2015 | Safety of machinery — Safety-related parts of control systems. |
| EN 61508-1:2010 | Functional safety of electrical/electronic/programmable electronic safety-related systems |
| EN 61508-2:2010 | Functional safety of electrical/electronic/programmable electronic safety-related systems |
| EN 61508-3:2010 | Functional safety of electrical/electronic/programmable electronic safety-related systems |

5.2. Electrical Safety

| Specification | Details |
|--------------------------------|---|
| Recognized UL 61800-5-1 | Adjustable speed electrical power drive systems: Safety requirements – Electrical, thermal and energy |
| CSA C22.2 NO. 274-17 | Adjustable speed drives |

5.3. Electromagnetic Compatibility

| Specification | Details |
|---------------------------------------|---|
| EN 61800-3:2004/A1:2011 | Adjustable speed electrical power drive systems Part 3: EMC requirements and specific test methods |
| EN 61800-5-2: 2017 Annex E | Adjustable speed electrical power drive systems Part 5-2: Safety requirements – Functional |



5.4. Environmental

| Specification | Details |
|---------------|-------------------------|
| IEC60068-2-78 | Damp heat, steady state |
| IEC60068-2-6 | Vibration (sinusoidal) |
| IEC60068-2-2 | Dry heat |
| IEC60068-2-27 | Shock |

5.5. Other Compliant Standards

For other compliant standards refer to the

[MAN-G-Board Level Modules Hardware Manual section 17.7](#) or refer to the Elmo website:

<https://www.elmomc.com/capabilities/standards-compliance/gold-family/>

5.6. CE Declaration

Refer to the complete EC Declaration of Conformity available on the internet at:

https://www.elmomc.com/wp-content/uploads/dlm_uploads/2018/05/Gold-Line-CE-Declaration-of-Conformity.pdf.

5.7. Dual Use

No export license is required for the Gold Line products signified with the suffix Q in the Part Number.

The operating frequency of the Gold Line products is “factory limited” to ≤ 599 Hz, and therefore complies with the EU Dual Use Regulation 428/2009, 3A225, and the US Dual Use regulation EAR ECCN# 3A225.

This statement applies to all identical specimens and will become invalid if a change is made in the firmware.



Chapter 6: Unpacking the Drive Components

Before you begin working with the Gold Twitter, verify that you have all of its components, as follows:

- The Gold Twitter servo drive
- The Elmo Application Studio (EASII) software and software manual

The Gold Twitter is shipped in a cardboard box with Styrofoam protection.

To unpack the Gold Twitter:

1. Carefully remove the servo drive from the box and the Styrofoam.
2. Check the drive to ensure that there is no visible damage to the instrument. If any damage has occurred, report it immediately to the carrier that delivered your drive.
3. To ensure that the Gold Twitter you have unpacked is the appropriate type for your requirements, locate the part number sticker on the side of the Gold Twitter. It looks like this:



4. Verify that the Gold Twitter type is the one that you ordered, and ensure that the voltage meets your specific requirements. The part number at the top provides the type designation. Refer to the appropriate part number in the section Catalog Number at the beginning of the installation guide.



Chapter 7: Mounting the Gold Twitter

The Gold Twitter was designed for mounting on a printed circuit board (PCB) via 1.27 mm pitch 0.40 mm square pins, 2 mm pitch 0.51 mm square pins and 3.65 mm pitch 1.02 mm round pins. When integrating the Gold Twitter into a device, be sure to leave about 1 cm (0.4") outward from the heat-sink to enable free air convection around the drive. We recommend that the Gold Twitter be soldered directly to the board. If the PCB is enclosed in a metal chassis, we recommend that the Gold Twitter be screw-mounted to it as well to help with heat dissipation. The Gold Twitter has screw-mount holes on each corner of the heat-sink for this purpose – see below

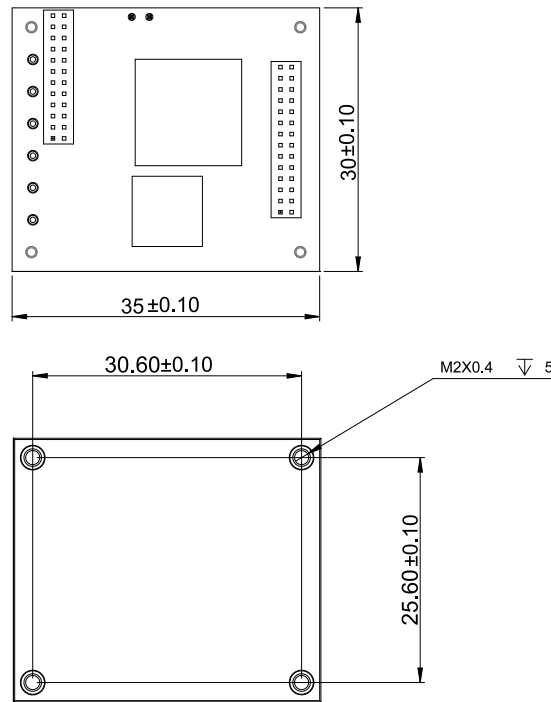

G-TWI001E

Figure 2: Gold Twitter CAN Version Dimensions1

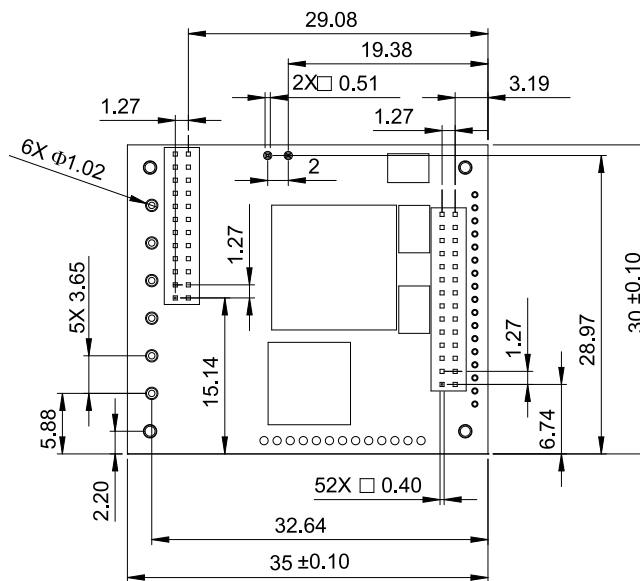

Figure 3: Gold Twitter CAN Version Dimensions2

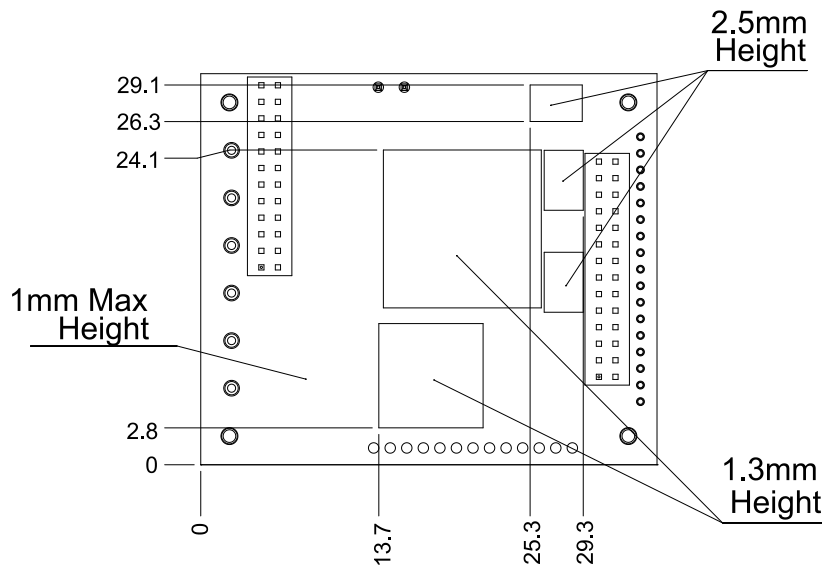

Figure 4: Gold Twitter CAN Version Dimensions3

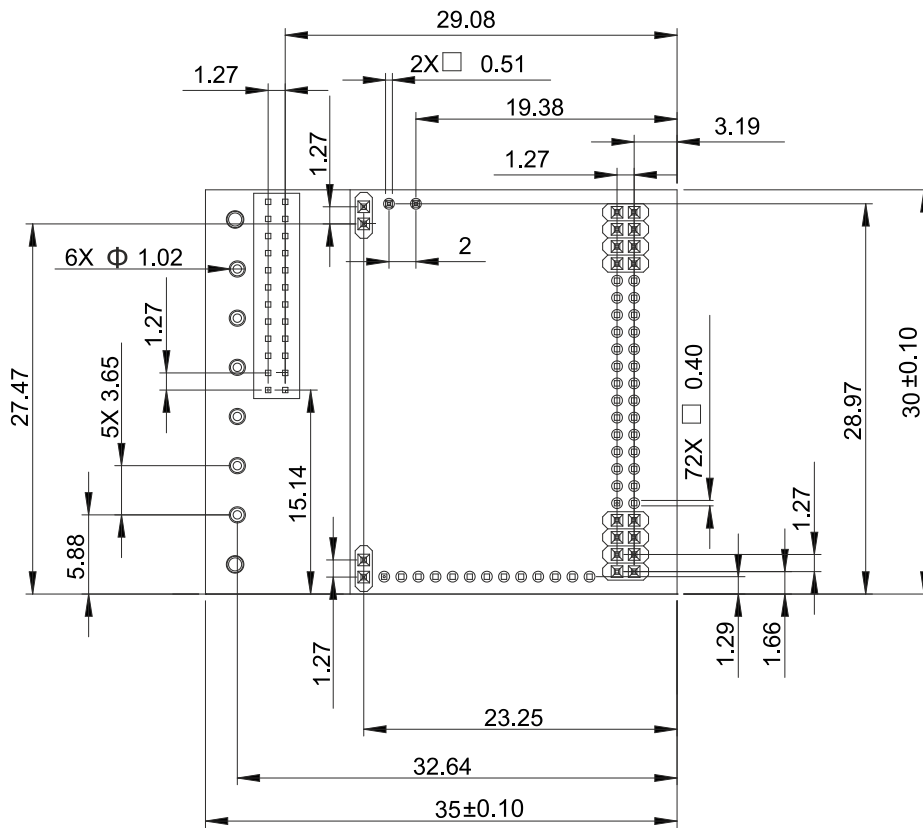
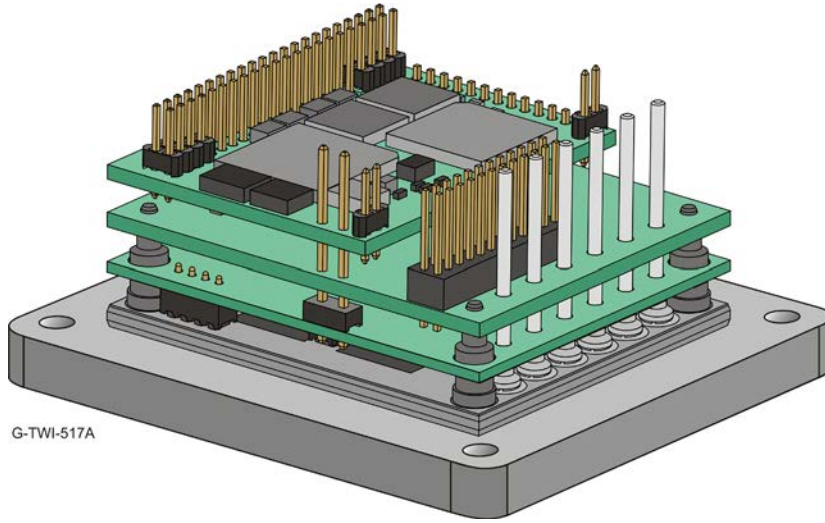

Figure 5: Gold Twitter EtherCAT Version Dimensions



7.1. Mounting the Optional Accessories Heat Sinks

There are two optional heat sinks, available as accessory kits (the model **G-TWIXXX/YYZZH** is integrated with the Flat Heatsink P/N G-TWIHSFLAT01):



G-TWI-517A

Flat Heat Sink (P/N G-TWIHSFLAT01)

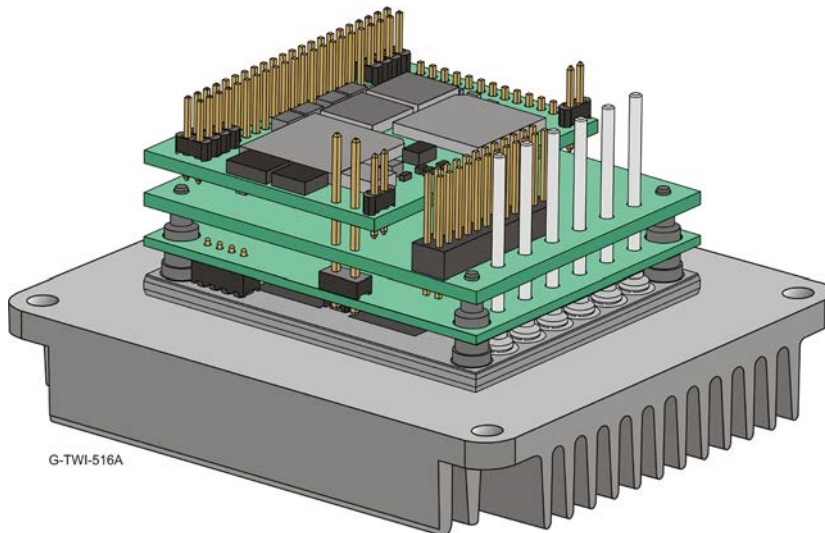

G-TWI-516A

Fins Heat Sink (P/N G-TWIHSFINS01)



The optional heat sink must be screwed to the lower surface of the Gold Twitter.

To mount the accessory heatsink (Not available for the option G-TWIXXX/YYZZH):

1. Mount the heat sink under the base of the Gold Twitter.
2. Place the Thermal foil (enclosed in the heat sink accessories kit) between the lower surface of the servo drive, and the upper surface of the heat sink.
3. Use four M2 screws (enclosed in the heat sink accessories kit) to secure the heat sink under the servo drive.
4. Tighten the screws to the relevant torque force applicable to an M2 stainless steel A2 screw.

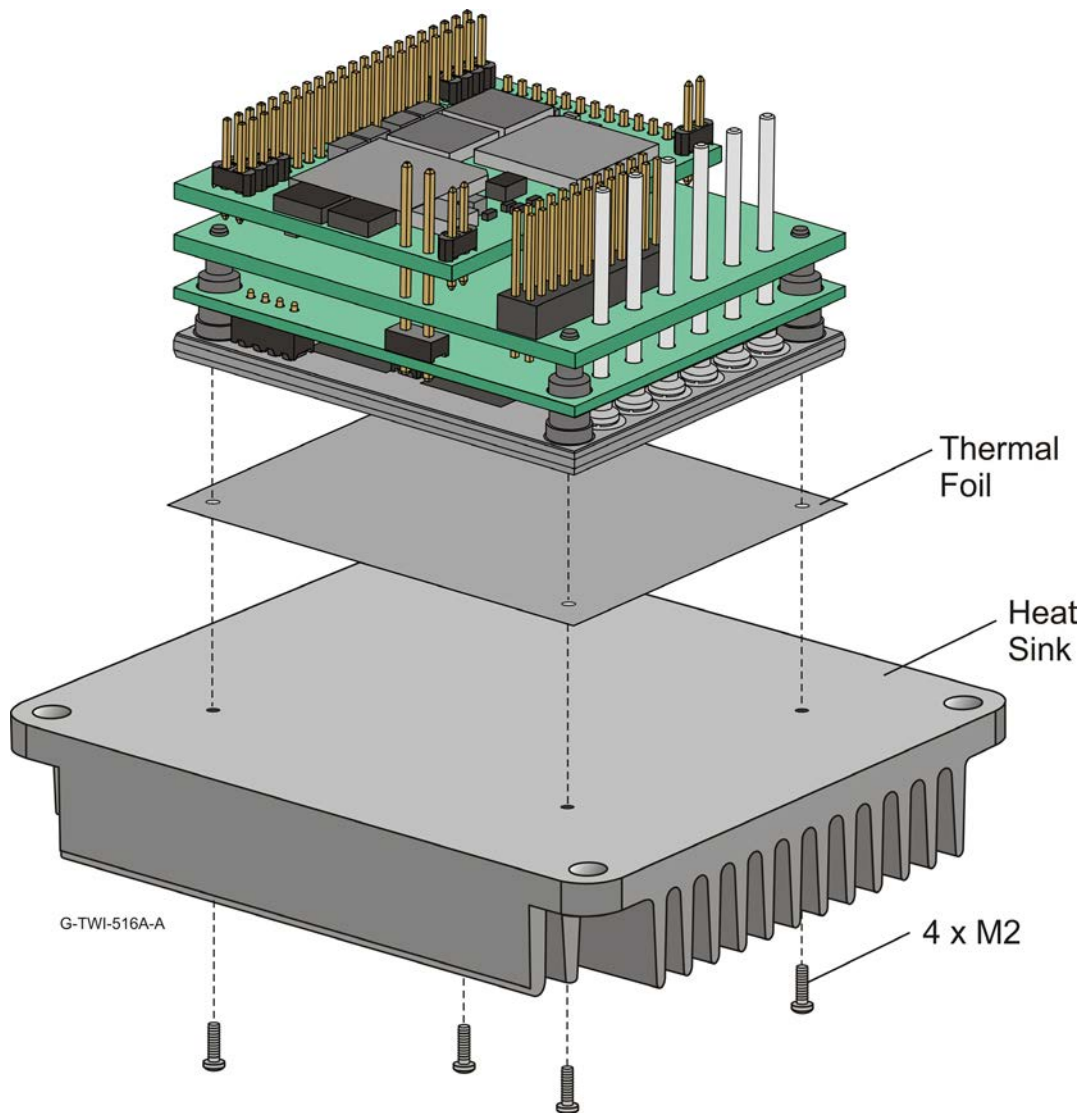

Figure 6: Mount the Heat Sink and Thermal Foil to the Gold Twitter



7.2. Mounting Gold Twitter to an External Heatsink

This option is only available for G-TWIXXX/YYZZH.

The selected heat sink must be screwed to the lower surface of the Gold Twitter.

To mount the Gold Twitter to an external heat sink:

1. Mount the heat sink under the base of the Gold Twitter.
2. Place the Thermal foil (PN IMT-GTWIALHFLAT purchased from Elmo) between the lower surface of the servo drive, and the upper surface of the heat sink.
3. Use four M2.5 head cup Allen screws to secure the heat sink under the servo drive.
4. Tighten the screws to the relevant torque force applicable to an M2.5 stainless steel A2 screw.

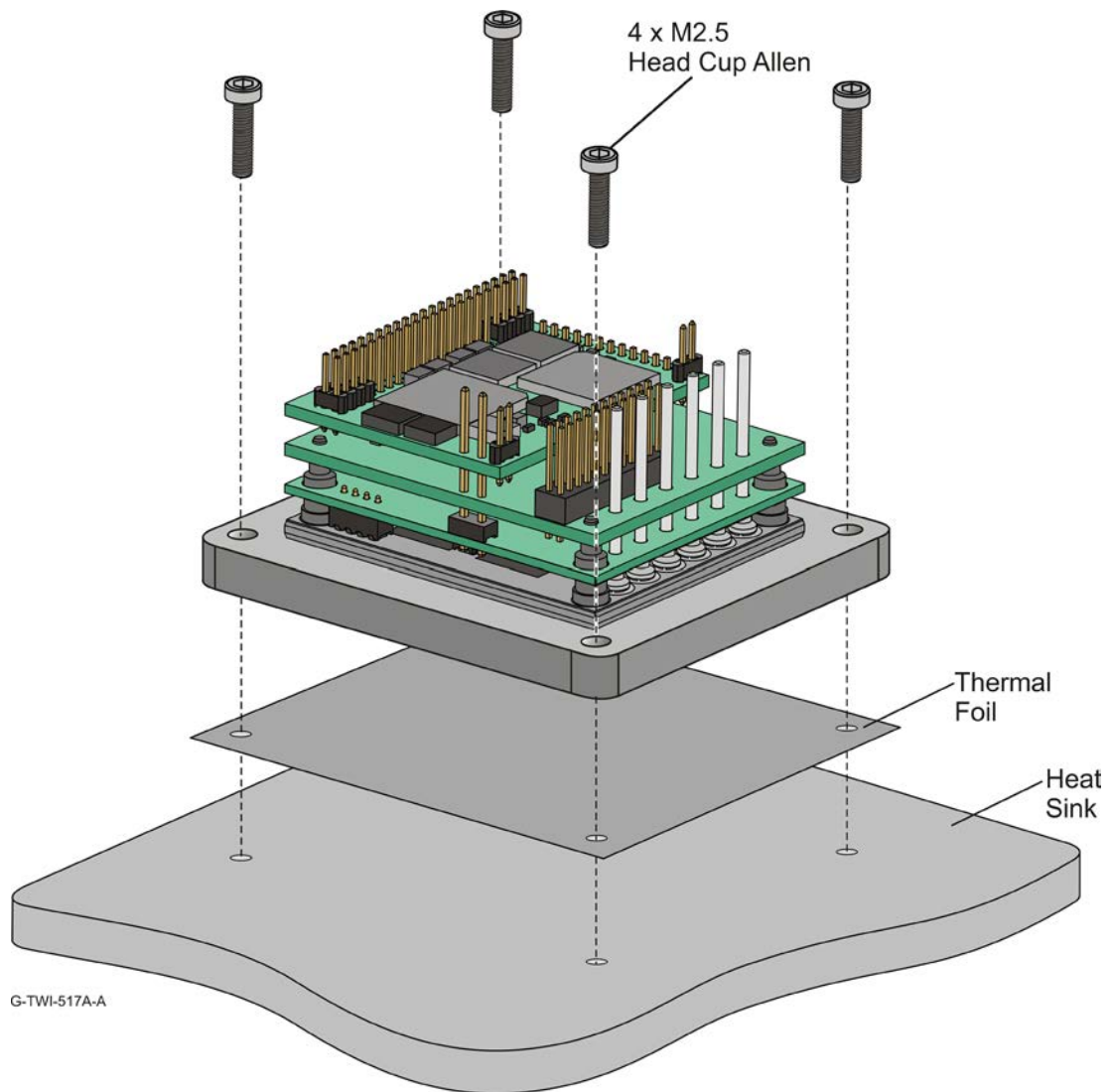

Figure 7: Mounting the Heat Sink and Thermal Foil to the Gold Twitter



Chapter 8: Integrating the Gold Twitter on a PCB

The Gold Twitter is designed to be mounted on a PCB by soldering its pins directly to the PCB. Refer to Chapter 5 in the MAN-G-Board Level Modules Hardware Manual for further information.

8.1. Power Returns (PR)

In the Gold Twitter, the power stage and control stage are internally connected, and the negative node of the DC power bus is designated as PR

The maximum realistic Power Return is achieved using a plane, which connects between the Gold Drive and the power source. The impedance on this plane must be as low as possible to reduce the impedance between the “Grounds”. This effectively reduces the levels of common mode differences, interferences, EMI etc.

8.2. COMRET

For details of the COMRET, refer to the section 5.4 in the MAN-G-Board Level Modules Hardware Manual.

8.3. Earth Connection (PE)

The PE (Earth connection) terminal is connected internally in the drive to the Gold Twitter’s chassis (heat-sink) which serves as an EMI common plane. Any other assembly metallic parts (such as the chassis) should also be connected to the PE.

Under normal operating conditions, the PE trace carries no current. The only time these traces carry current is under unusual conditions (such as when the device has become a potential shock or fire hazard while conducting external EMI interferences directly to ground). When connected properly the PE trace prevents these hazards from affecting the drive.



8.4. Power Return (PR), Common Return (COMRET) and Earth Connections (PE)

Safety regulations (UL61800-5-1, IEC61800-5-1, and UL508C) require that the servo drive, as a “stand alone”, must withstand breakdown voltages of 2KV for the 200V models, and 1.7KV for the 100V models, between PE to PR. However, the connections between PE to PR and the COMRET are essential for the safe operation of the servo drive. Therefore the following topology must be used:

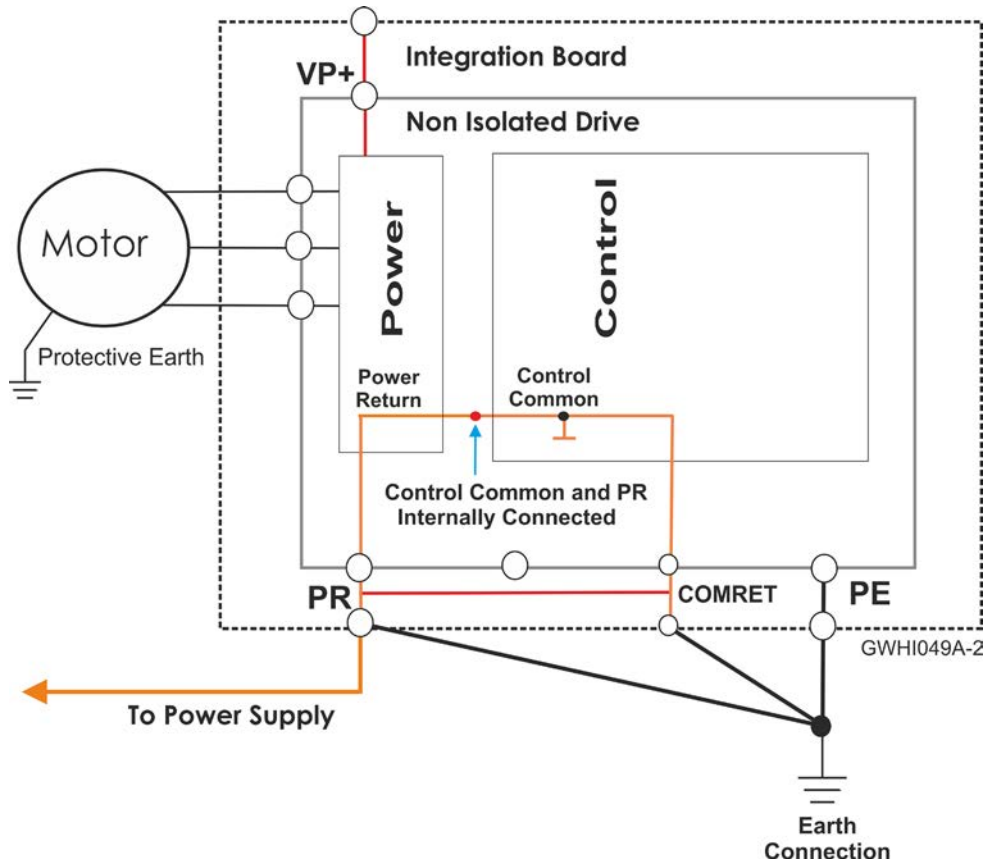

Figure 8: Gold Twitter Earth Connections

The connections to PE are essential, but must be done externally to the integration board. The COMRET should be connected to the PR in the Integration Board.



8.5. Logic and Control Cabling and Wiring

8.5.1. Feedback ports, VL, RS232, USB, Analog Input

For short distances between the drive and control, 0.5 to 1.0 m wires can be used and shielding is not required. For longer distances than 1.0 m and/or high EMI environment, shielded and twisted wires should be used. Drain wires should be connected to Elmo COMRET.

8.5.2. Digital Inputs/Outputs, STO

Wires can be always used, no need for twisting, no need for shielding.

8.5.3. EtherCAT or CAN Communication

Always use CAT5e cables.

8.5.4. COMRET to PE Connection

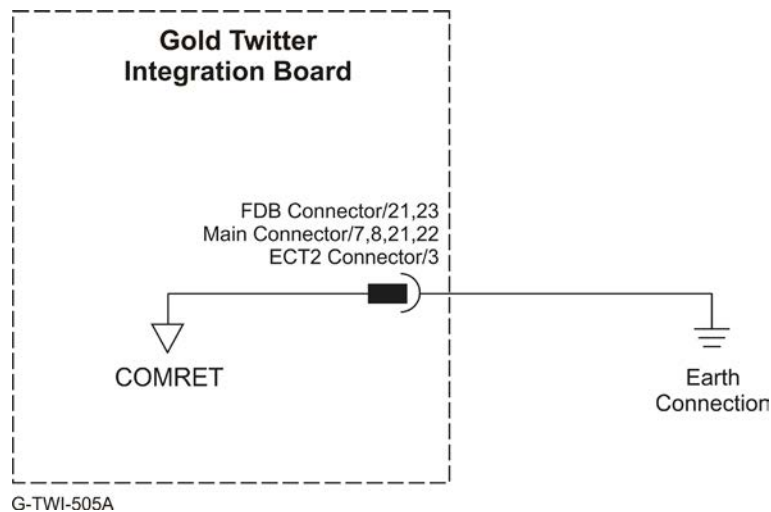

Figure 9: COMRET Connection to the PE

At least one COMRET pin (Figure 9) must be connected to the Protective Earth (PE).

Earthing the COMRET by connecting the Earth (PE) to the drive COMRET is mandatory to insure reliable operation, high noise immunity and rejection of voltage common mode interferences.



8.6. Power Conductors PCB layout

The PCB virtually divided into two zones; Power Zone, and Control & Communication Zone.

- **Power Zone**
This area is dedicated to Power conductors only: VP+, PR, PE, VL+, VL-, and motor leads.
- **Control and Communication Zone**
This area of the PCB is dedicated to Control low level signals

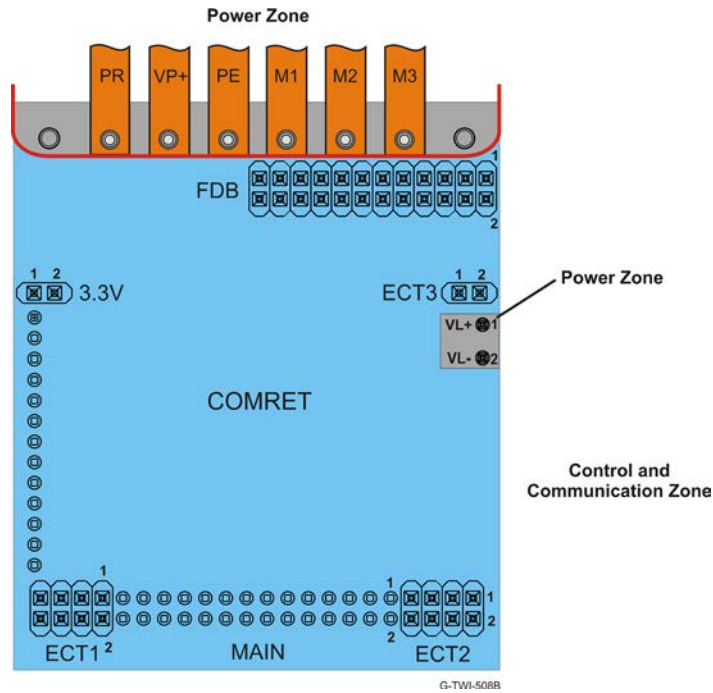

Figure 10: Gold Twitter EtherCAT Power Conductors PCB layout

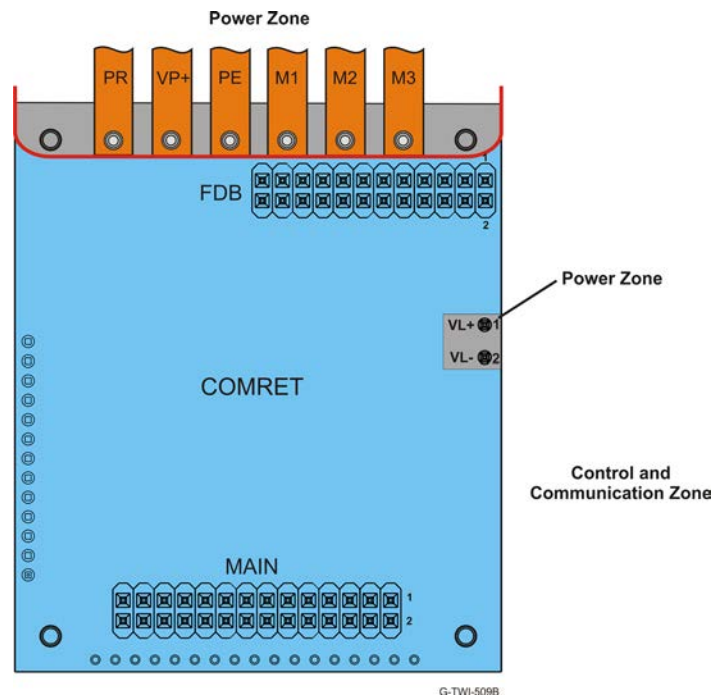

Figure 11: Gold Twitter CAN Power Conductors PCB layout

For more details, refer to the section 5.4 in the MAN-G-Board Level Modules Hardware Manual.



Chapter 9: Wiring

9.1. Wiring Legend

The following table legend describes the wiring symbols detailed in all installation guides. All the wiring diagrams show wiring for D-TYPE connectors.

| Wiring Symbol | Description |
|---|---|
| | Earth connection (PE) |
| | Protective Earth Connection |
| | Common at the Controller |
| | Shielded cable with drain wire. The drain wire is a non-insulated wire that is in direct contact with the braid (shielding). Shielded cable with drain wire significantly simplifies the wiring and earthing. |
| | Shielded cable braid only, without drain wire. |
| | Twisted-pair wires |
| <p>Encoder Earthing. The cable's shield is connected to the chassis (PE) in the connector. Earthing the Encoder and connecting the Earth (PE) to the drive COMRET is mandatory to insure reliable operation, high noise immunity and rejection of voltage common mode interferences.</p> | |



9.2. The Gold Twitter Connection Diagram

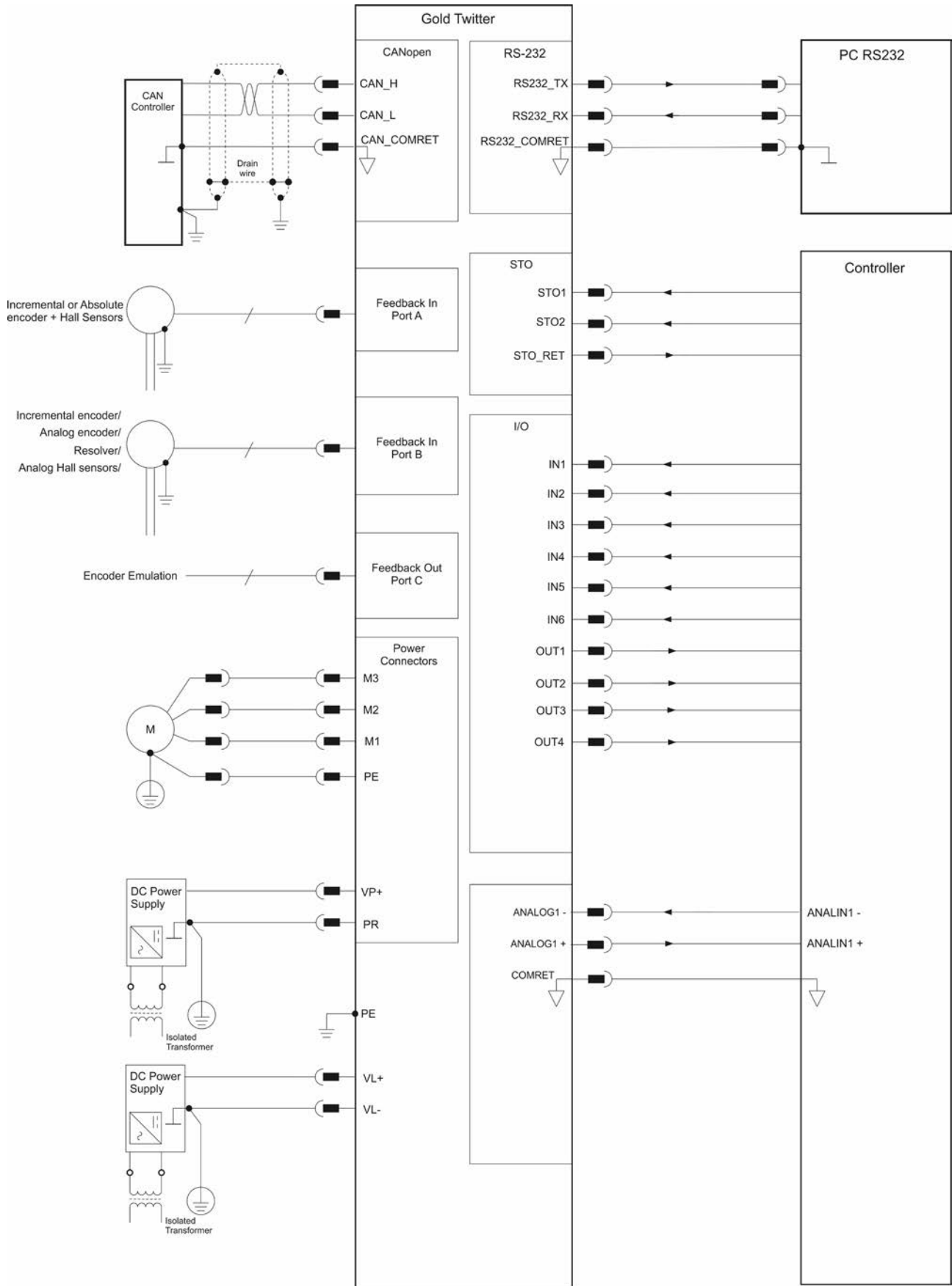

G-TWI-506B

Figure 12: The Gold Twitter CAN Connection Diagram

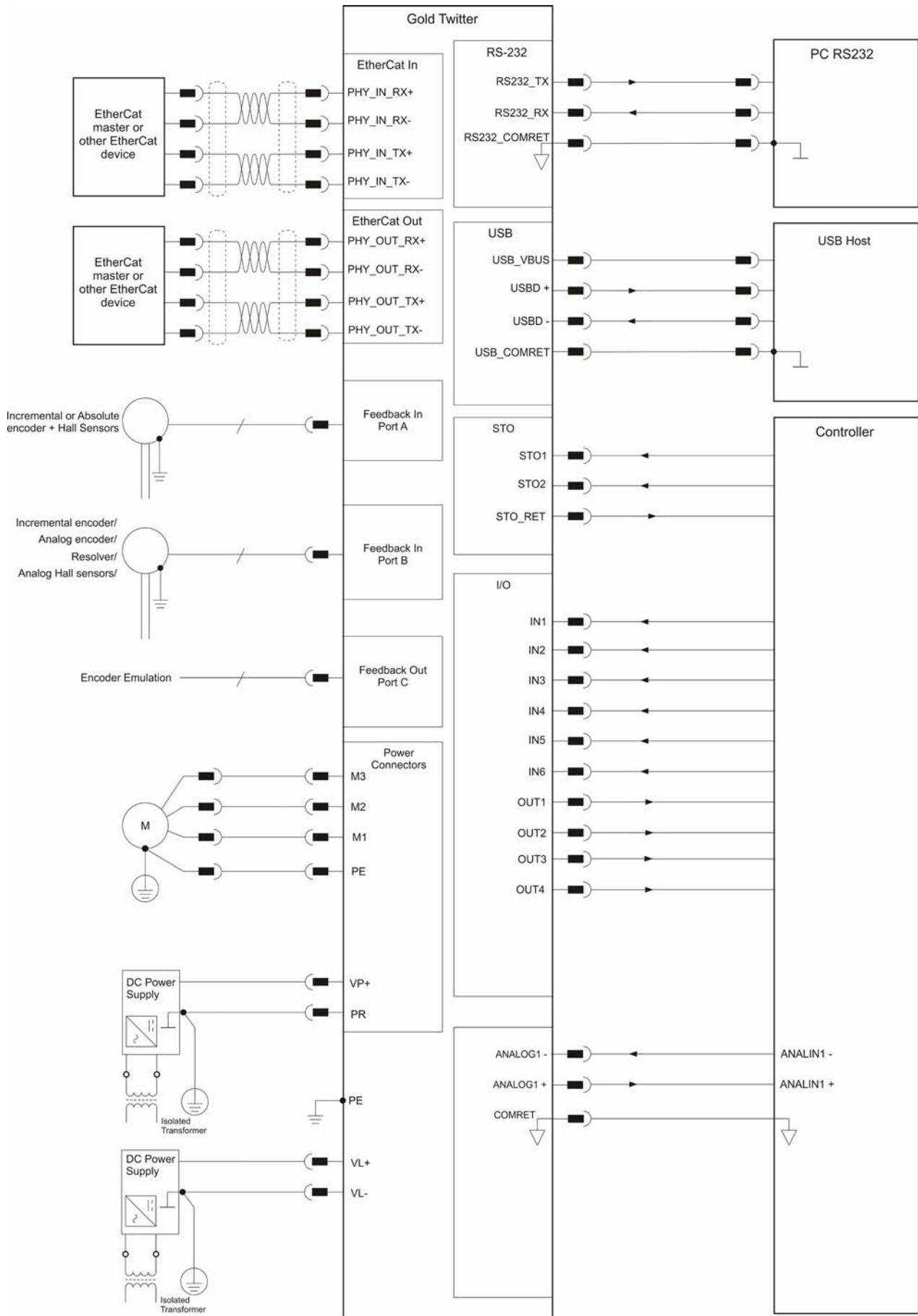

G-TWI-507B

Figure 13: The Gold Twitter EtherCAT Connection Diagram



Chapter 10: Connections

The Gold Twitter has nine connectors.

| Port | Pins | Type | Function |
|-------|------|----------------------------------|--|
| FDB | 2x12 | 1.27 mm pitch 0.40 mm sq. | Feedbacks, Digital Halls, Analog Inputs, Communications |
| M3 | 1x1 | 3.65 mm pitch 1.02 mm round pins | Motor power output 3 |
| M2 | 1x1 | | Motor power output 2 |
| M1 | 1x1 | | Motor power output 1 |
| PE | 1x1 | | Protective earth |
| PR | 1x1 | | Power output return |
| VP+ | 1x1 | | DC Positive power input |
| VL+ | 1x2 | | 2 mm pitch 0.51 mm sq. |
| VL- | | VL- | |
| MAIN | 2x14 | 1.27 mm pitch 0.40 mm sq. | I/O, LEDs, STO, CAN or EtherCAT |
| ECT1 | 2x4 | 1.27 mm pitch 0.40 mm sq. | Available only for EtherCAT Version |
| ECT2 | 2x4 | 1.27 mm pitch 0.40 mm sq. | Available only for EtherCAT Version |
| ECT3 | 1x2 | 1.27 mm pitch 0.40 mm sq. | Available only for EtherCAT Version |
| 3.3 V | 1x2 | 1.27 mm pitch 0.40 mm sq. | Available only for EtherCAT Version Only for LEDS end Transformer |



Connectors Location

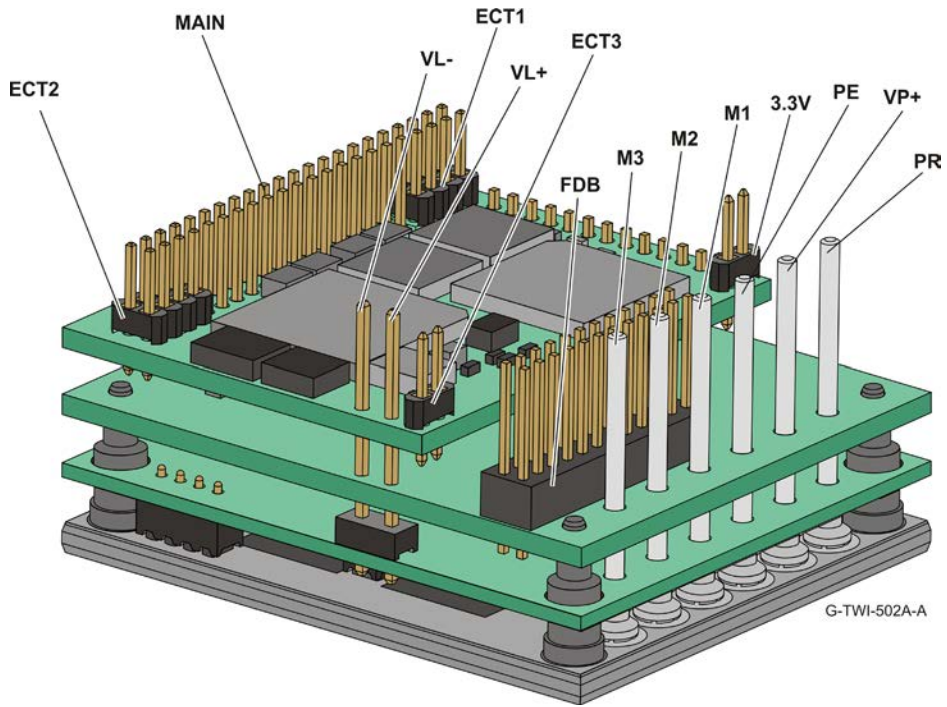

EtherCAT Version

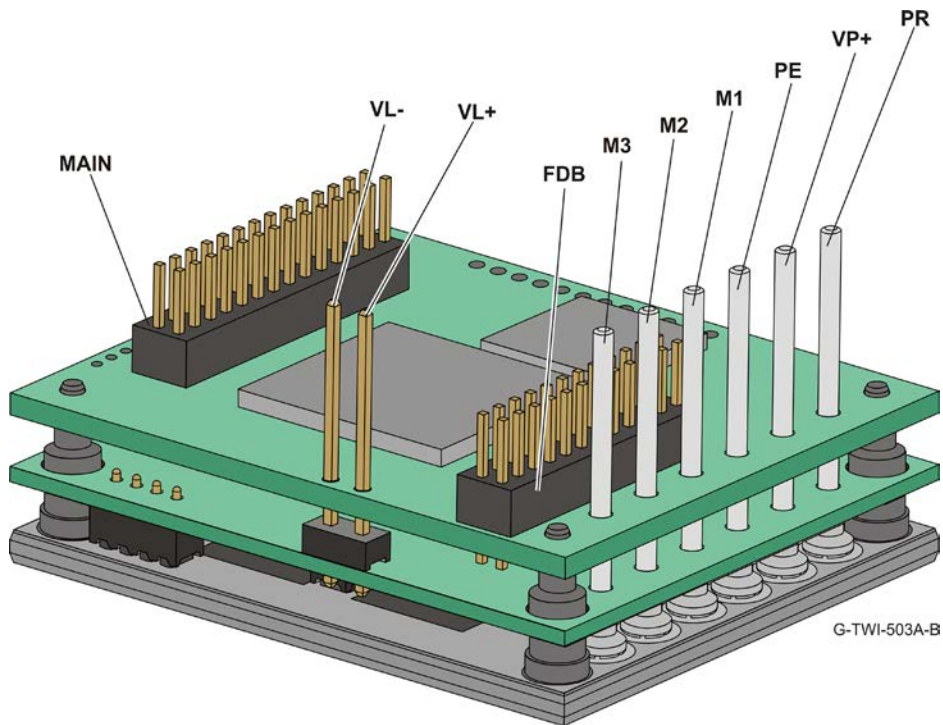

CAN Version

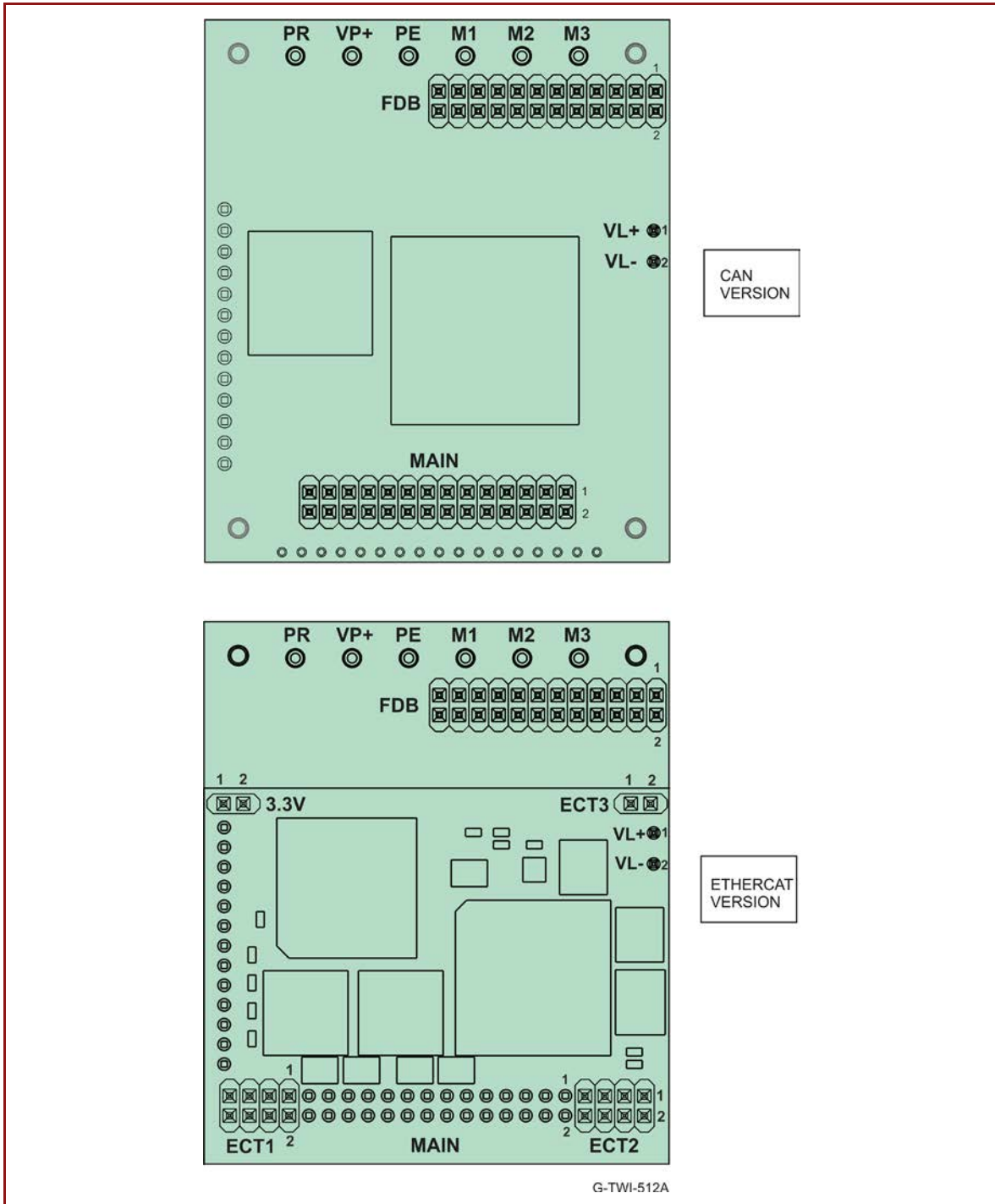

Table 4: Connector Types



10.1. Motor Power

This section describes the Motor Power.

For full details see Section 7.3 in the manual: MAN-G-Board Level Modules Hardware manual.

| Pin | Function | Cable | | Pin Positions |
|-----|------------------|-----------------|------------------|---------------|
| | | Brushless Motor | Brushed DC Motor | |
| PE | Connection earth | Motor | Motor | |
| M1 | Motor phase | Motor | N/C | |
| M2 | Motor phase | Motor | Motor | |
| M3 | Motor phase | Motor | Motor | |
| | | | | |

Table 5: Motor Connector

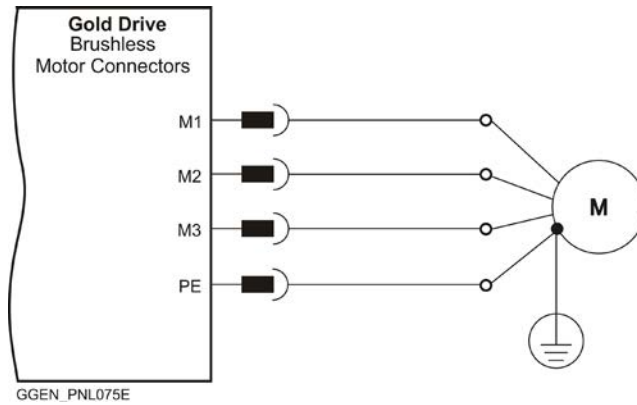

Figure 14: Brushless Motor Power Connection Diagram

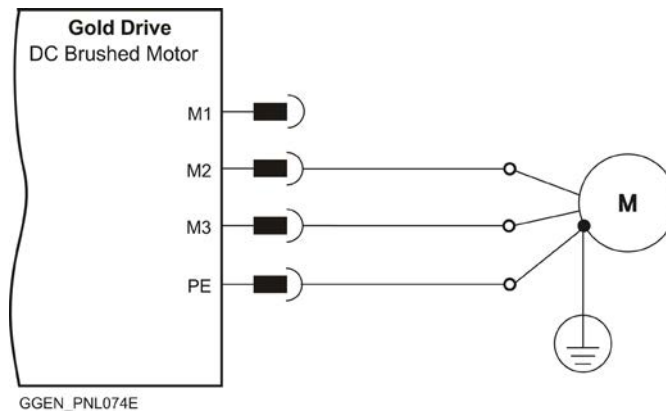

Figure 15: Brushed Motor Power Connection Diagram



10.1.1. Motor Power Connections

1. Ensure that the motor chassis is properly earthed.
2. Connect the appropriate wire from the Motor Power cables to the M1, M2, M3, and PE terminals on the Gold Twitter.

Make sure not to bundle the wires.

The phase connection is arbitrary as Elmo Application Studio (EAS II) will establish the proper commutation automatically during setup. When tuning a number of drives, you can copy the setup file to the other drives and thus avoid tuning each drive separately. In this case the motor-phase order must be the same as on the first drive.

3. For high EMI environment, it is highly recommended to use a 4-wire shielded (not twisted) cable for the motor connection. The gauge is determined by the actual RMS current consumption of the motor.

Connect the cable shield to the closest ground connection at the motor end.

For better EMI performance, the shield should be connected to Earth Connection (heat sink mounting holes).



10.2. Main Power and Control Connector

This section describes the Main Power and the Control supply connector.

10.2.1. Main Power

The VDC isolated from the Mains DC power source is not included with the Gold Twitter.

| Pin | Function | Cable | Pin Positions |
|-----|---------------------|-------|---------------|
| VP+ | DC Pos. Power input | Power | |
| PR | Power output return | Power | |
| PE | Protective earth | Power | |
| | | | |

Table 6: Connector for Main Power

Connect the DC power cable to the VP+ and PR terminals on the main power connector.

To connect the Gold Twitter to the DC power source:

1. The source of the VDC power supply must be isolated from the Mains.
2. Verify that the rectified VDC is indeed within the range of the drive.
3. Connect the VP+ and PR wires to the terminals on the servo-drive.
It is highly recommended to twist the two DC main power cables at intervals of 10 cm.
4. Connect the PE to the closest earth connection near the power supply.
5. Connect the PR to the closest earth connection near the power supply.
6. Before applying power, first verify the polarity of the connection.



10.2.2. Control Supply

Connect the VL+ and VL- pins on the Gold Twitter in the manner described in the table and drawing below.

| Pin | Signal | Function | Pin Positions |
|--|--------|-----------------------|---------------|
| 1 | VL+ | Control Supply Input | |
| 2 | VL- | Control Supply Return | |
| <ol style="list-style-type: none"> Standard CAN (G-TWIXXX/YYYSZ(Blank)) Input range: 12 – 40VDC Power consumption: <2.5W (including up to 200mA@5V for encoder) EtherCAT (G-TWIXXX/YYEZ(Blank)) Input range: 14 – 40VDC Power consumption: <4W (including up to 200mA@5V for encoder) Standard CAN (G-TWIXXX/YYYSZS or H) Input range: 12 – 95VDC Power consumption: <2.5W (including up to 200mA@5V for encoder) EtherCAT (G-TWIXXX/YYEZS or H) Input range: 12 – 95VDC Power consumption: <4W (including up to 200mA@5V for encoder) | | | |

Table 7: Control Supply Pins

Connect the VL+ and VL- terminals to the power supply Control Connector.

To connect the VL+ and VL- to the control supply:

- The source of the control supply must be isolated from the Mains.
- Connect the return (common) of the control supply source to the closest earth connection near the control supply source.
- Connect the VL+ and VL- wires to the terminals on the servo-drive.

For short distances between the drive and control, 0.5 to 1.0 m wires can be used and shielding is not required. For longer distances than 1.0 m and/or high EMI environment, shielded and twisted wires should be used. Drain wires should be connected to Elmo COMRET.

- Before applying power, first verify the polarity of the connection.

Note: For VL 12 to 40VDC (**G-TWIXXX/YYZZ(Blank)**) refer to section 10.2.3.

For VL 12 to 95VDC (**G-TWIXXX/YYZZS or H**) refer to section 10.2.4.



10.2.3. Control Supply Connections for G-TWIXXX/YYYYZZ(Blank)

Note: This section is for VL 12 to 40VDC (G-TWIXXX/YYYYZZ(Blank)).

For VL 12 to 95VDC (G-TWIXXX/YYYYZZS or H) refer to section 10.2.4.

10.2.3.1. Dual Power Supply Topology

Two DC power sources isolated-from-the-mains are required:

- A main DC power source derived from the Mains, according to specification
- A control supply for the logic

10.2.3.1.1 Ordinary Option

This option describes an Ordinary power supply for Servo drives with sufficient internal capacitance and shunt regulator to handle power flow in both directions to-and-from the motor. The following figure describes this connection of main power and control power.

Note: The PR and the VL- are connected internally in the Gold Twitter.

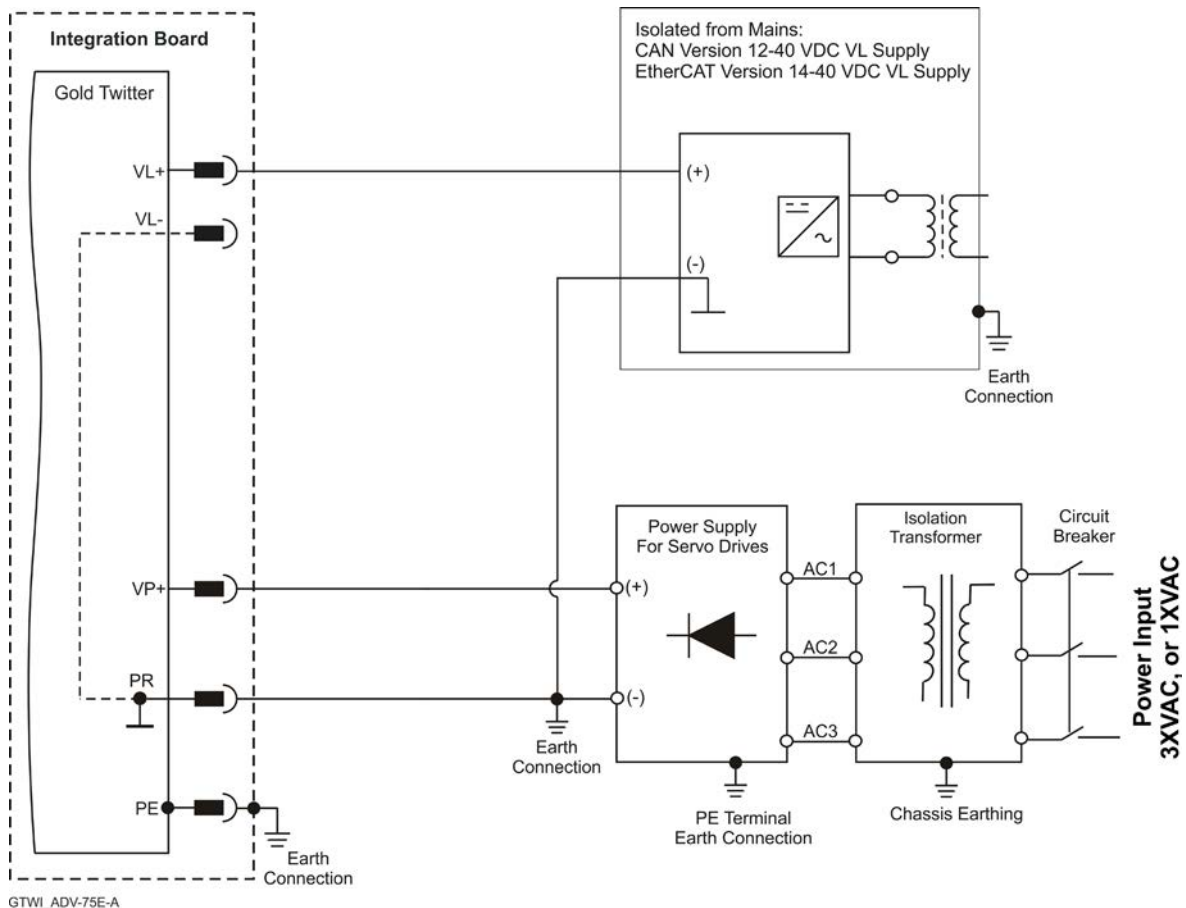

Figure 16: Ordinary Option: Separate VP and VL Power Supplies Connection Diagram

The (+) of the control power supply is connected to the VL+ terminal, while the (-) of the control power supply is connected directly to the (-) of the DC bus power supply. This connection avoids high current ground loops due to poor wiring (Figure 16).



10.2.3.1.2 SMPS Option

This option describes a topology with a main power without regeneration, but with limited Braking capabilities dependent on additional capacitance.

The C_{external} can be mounted on the Integration Board if there are no space limitations.

Minimum capacitance of the Power supply: $C_{\text{external}} > \text{“Drive’s Rated Current”} * 20\mu\text{F}$

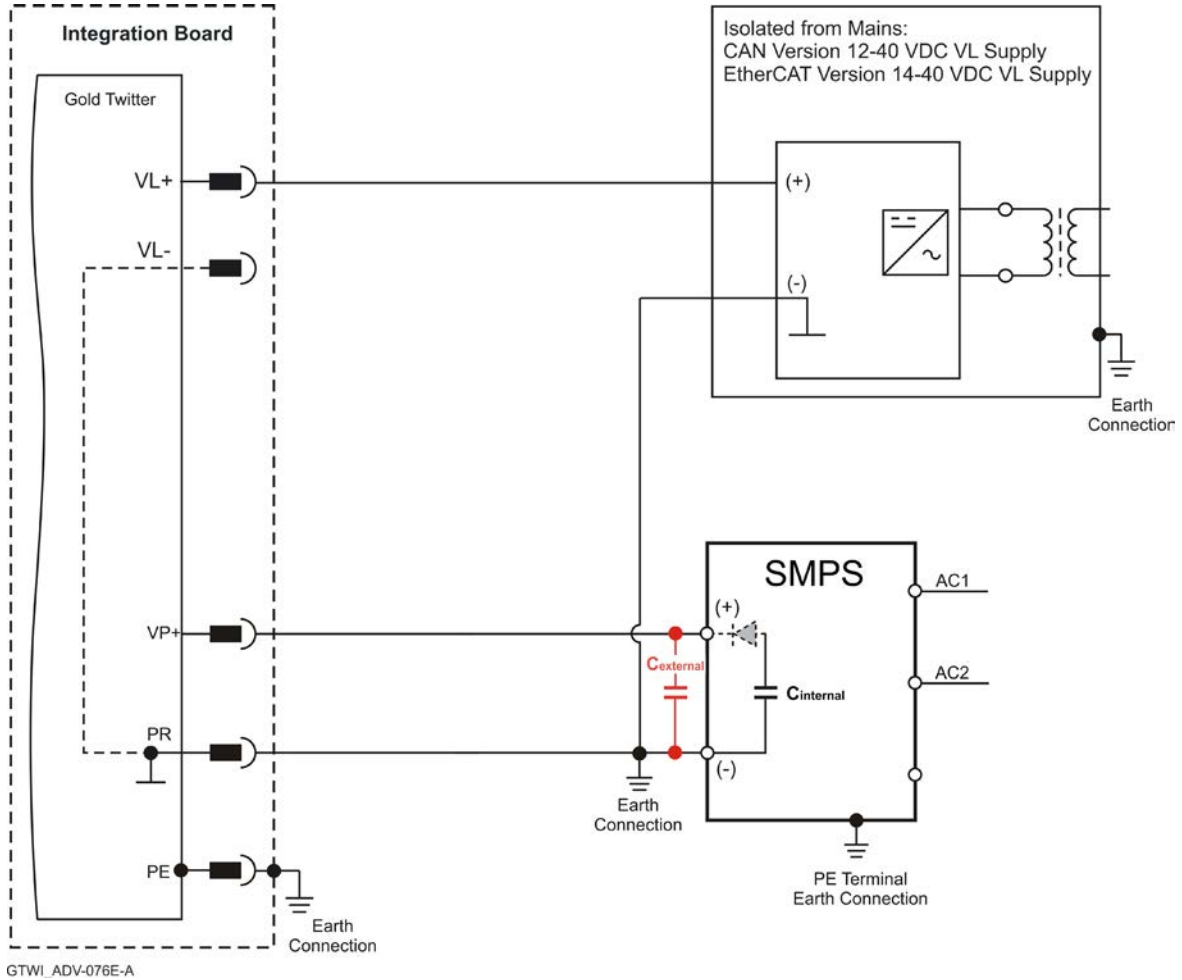

Figure 17: SMPS Option: Separate VP and VL Power Supplies Connection Diagram

The (+) of the control power supply is connected to the VL+ terminal, while the (-) of the control power supply is connected directly to the (-) of the DC bus power supply. This connection avoids high current ground loops due to poor wiring (Figure 17).



10.2.3.2. Single Power Supply Topology (VP+ < 40VDC)

A single power supply can be used to power both the main and control. For the CAN version power rating of minimum 12 to 40VDC, or minimum 14 to 40VDC for the EtherCAT version.

When regeneration or braking occurs, the DC bus may increase and may exceed the VL limit of over 40VDC, possibly causing the VL to fail. Under these conditions, you must install the Dual Power Supply described above in section 10.2.3.1.

10.2.3.2.1 Recommended Option

This option describes an Ordinary power supply for Servo drives with sufficient internal capacitance and shunt regulator to handle power flow in both directions to-and-from the motor. In this configuration the Gold Twitter max operating voltage depends on the model, and is 55VDC, 75VDC, or 95VDC. However the DC bus must be limited to VP+ <40VDC to prevent failure of the VL supply.

The following figure describes this connection of main power and control.

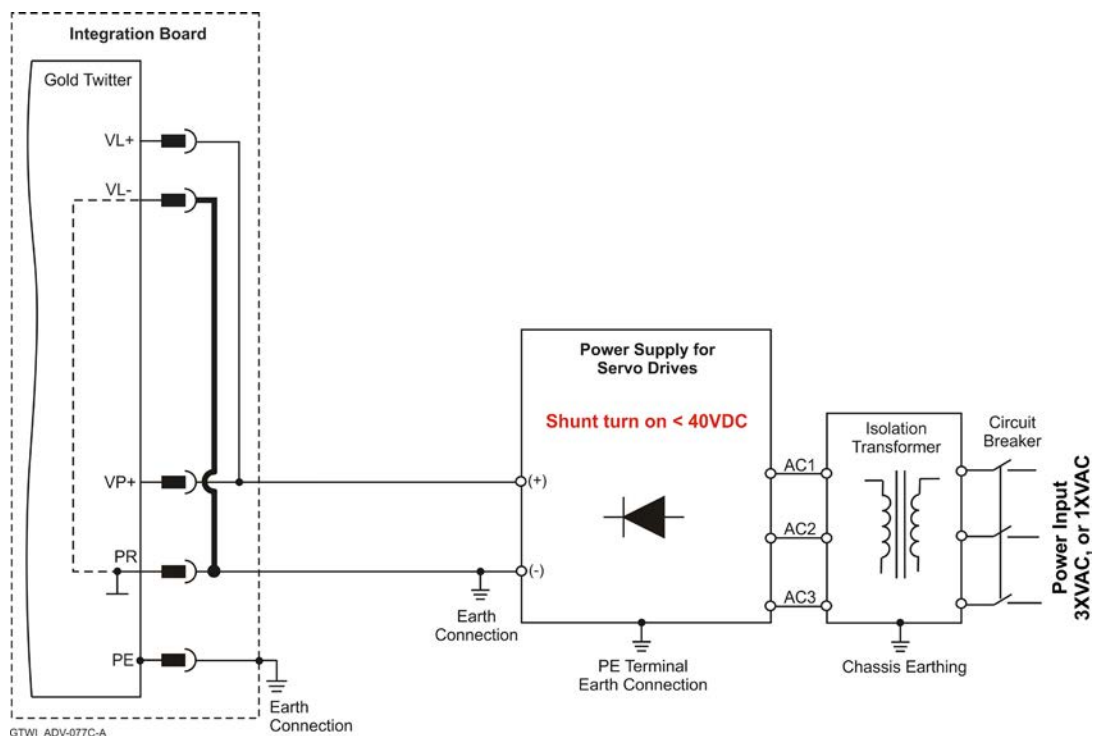

Figure 18: Recommended Single Power Supply (VP+<40V) Connection Diagram with VL+ Connected Internally

Note: This option is available for power supply up to 40VDC.

For applications where the recommended single power supply is used, the following conditions must apply:

- The “Shunt On” trip voltage in the power supply must be <40VDC
- If there is no shunt in the Power Supply the Over Voltage must be programmed using the drive software command $XP[1]=38$ (over-voltage set to 38V)
- Minimum capacitance of the Power supply: $C_{Power_Supply} > \text{Drive's Rated Current} * 20\mu F$
- The VL- to PR is connected on the Integration Board (no external wiring)
- The VL- to PR connection must be as thick as possible, actually a Ground Plane is most preferable



10.2.3.2.2 SMPS Option

This option describes a main power and control topology without regeneration, but with limited Braking capabilities dependent on additional capacitance.

The C_{external} can be mounted on the Integration Board if there are no space limitations.

In this configuration the Gold Twitter max operating voltage depends on the model, and is 55VDC, 75VDC, or 95VDC. However the DC bus must be limited to $VP+ < 40\text{VDC}$ to prevent failure of the VL supply.

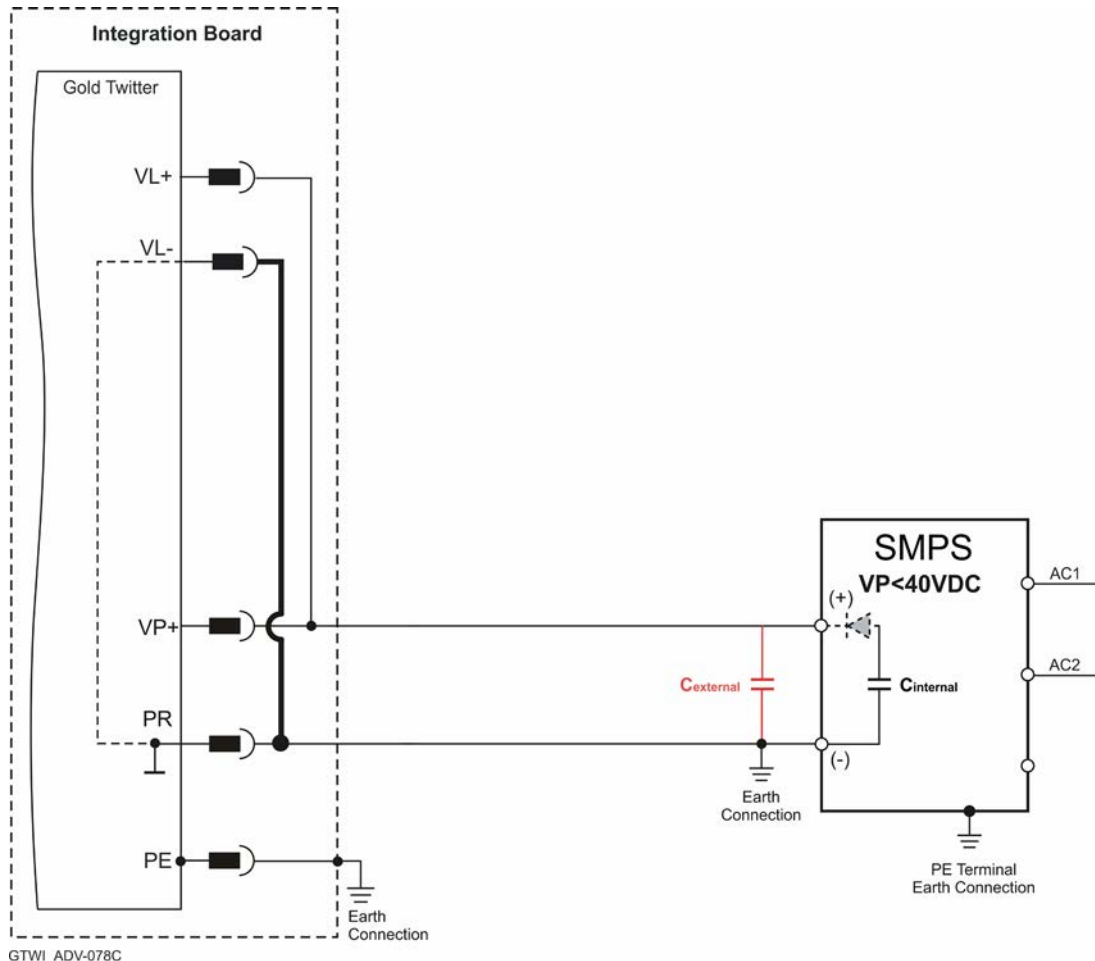

Figure 19: SMPS Single Power Supply ($VP+ < 40\text{V}$) Connection Diagram with VL+ Connected Internally

Note: This option is available for power supply up to 40VDC.

For applications where a SMPS single power supply is used, the following conditions must apply:

- External capacitance must be added on the DC bus
- The Over Voltage of the Gold Twitter must be programmed using the drive software command $XP[1]=38$ (over-voltage set to 38V)
- The Minimum capacitance of the Power supply: $C_{\text{external}} > \text{“Drive’s Rated Current”} * 20\mu\text{F}$
- The VL- to PR is connected on the Integration Board (no external wiring)
- The VL- to PR connection must be as thick as possible, actually a “Ground Plane” is most preferable



10.2.3.2.3 Forbidden Option

Do NOT use the following wiring topology. Only connect the VL- to PR internally on the Integration Board.

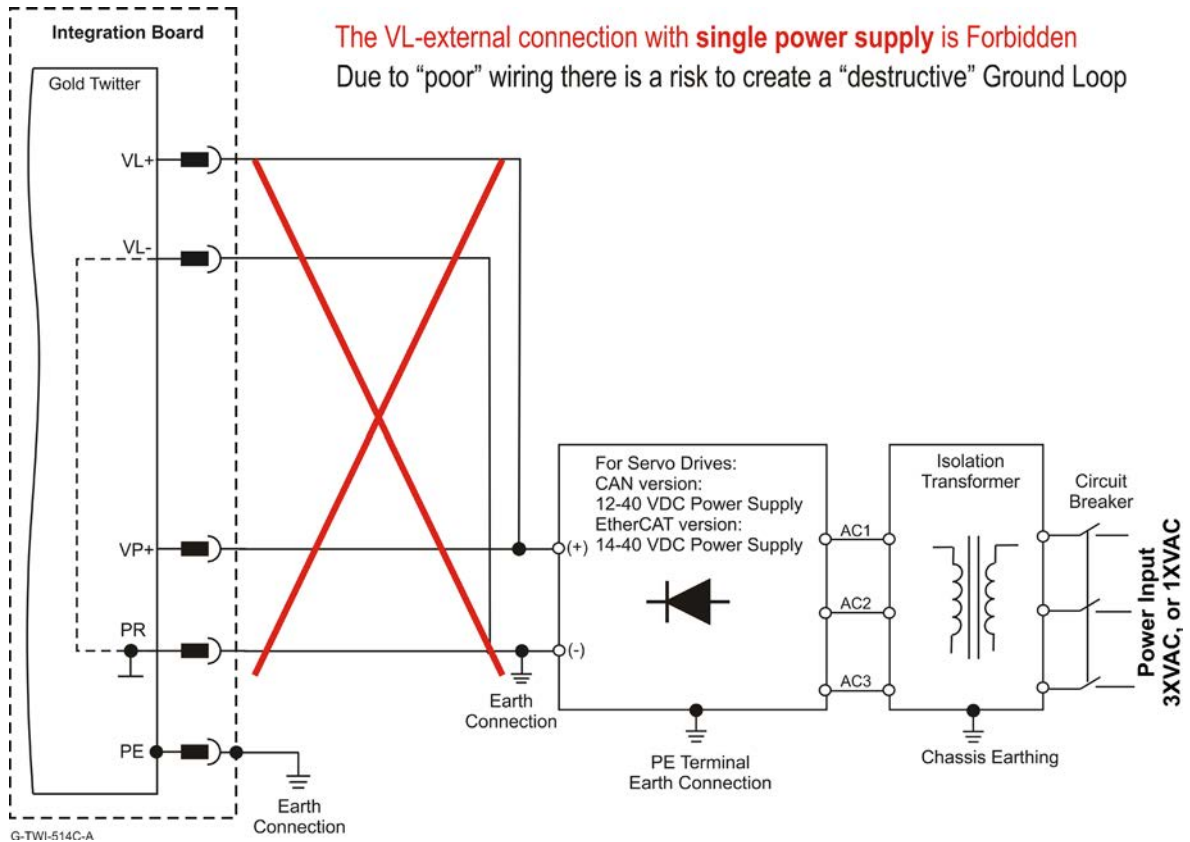

Figure 20: Forbidden Single Power Supply (<40V) Connection Diagram with VL+ Cable Connected Externally



10.2.4. Control Supply Connections for G-TWIXXX/YYYYZZS or H

Note: This section is for VL 12 to 95VDC (G-TWIXXX/YYYYZZS or H).

For VL 12 to 40VDC (G-TWIXXX/YYYYZZ(Blank)) refer to section 10.2.3.

10.2.4.1. Dual Power Supply Topology

Two DC power sources isolated-from-the-mains are required:

- A main DC power source derived from the Mains, according to specification
- A control supply for the logic

10.2.4.1.1 Ordinary Option

This option describes an ordinary power supply for Servo drives with sufficient internal capacitance and shunt regulator to handle power flow in both directions to-and-from the motor. The following figure describes this connection of main power and control power.

Note: The PR and the VL- are connected internally in the Gold Twitter.

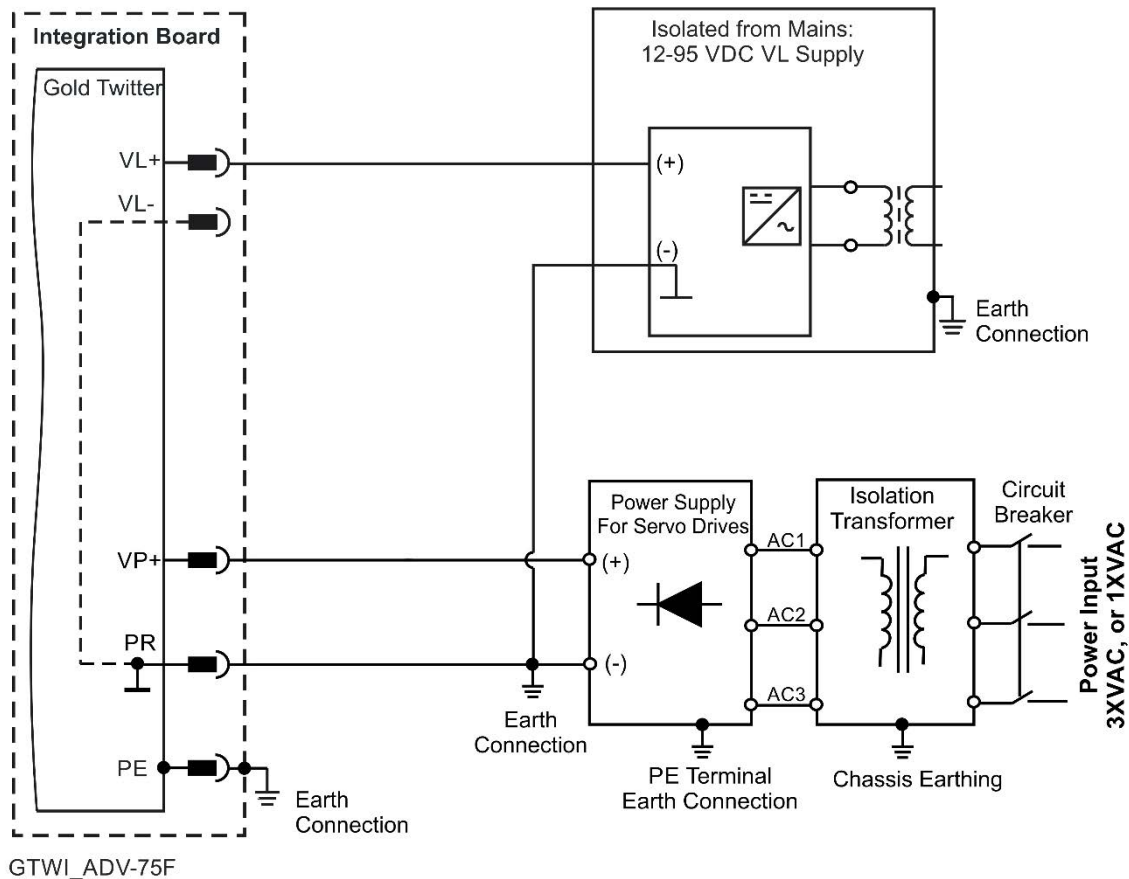

Figure 21: Ordinary Option: Separate VP and VL Power Supplies Connection Diagram

The (+) of the control power supply is connected to the VL+ terminal, while the (-) of the control power supply is connected directly to the (-) of the DC bus power supply. This connection avoids high current ground loops due to poor wiring (Figure 21).



10.2.4.1.2 SMPS Option

This option describes a topology with a main power without regeneration, but with limited Braking capabilities dependent on additional capacitance.

The C_{external} can be mounted on the Integration Board if there are no space limitations.

Minimum capacitance of the Power supply: $C_{\text{external}} > \text{“Drive’s Rated Current”} * 20\mu\text{F}$

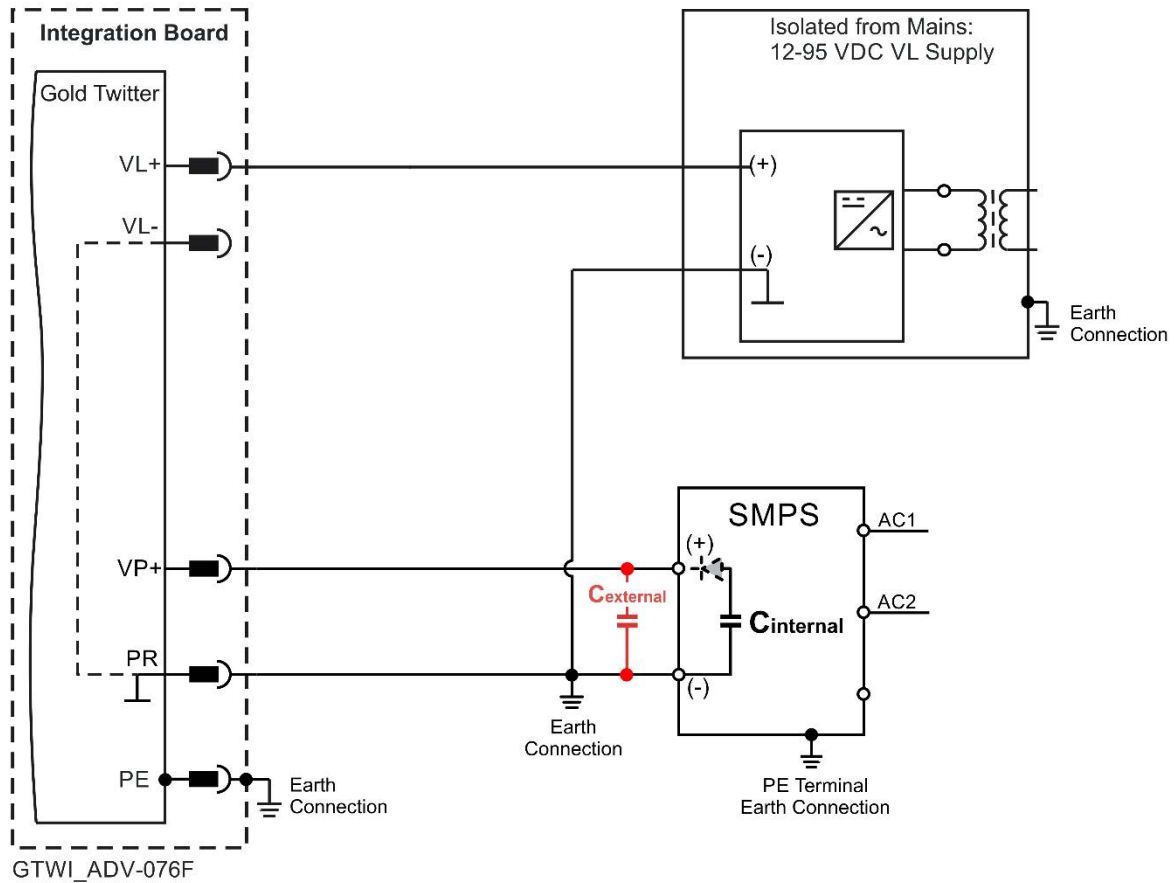

Figure 22: SMPS Option: Separate VP and VL Power Supplies Connection Diagram

The (+) of the control power supply is connected to the VL+ terminal, while the (-) of the control power supply is connected directly to the (-) of the DC bus power supply. This connection avoids high current ground loops due to poor wiring (Figure 22).



10.2.4.2. Single Power Supply Topology (VP+ < 95VDC)

A single power supply can be used to power both the main and control within the range of 12 to 95VDC.

10.2.4.2.1 Recommended Option

This option describes an ordinary power supply for Servo drives with sufficient internal capacitance and shunt regulator to handle power flow in both directions to-and-from the motor. In the configuration of the 200V Gold Twitter model, the max operating voltage is 195VDC, but the DC bus must be limited to VP+ < 95VDC to prevent failure of the VL supply.

The following figure describes a single connection of main power and control.

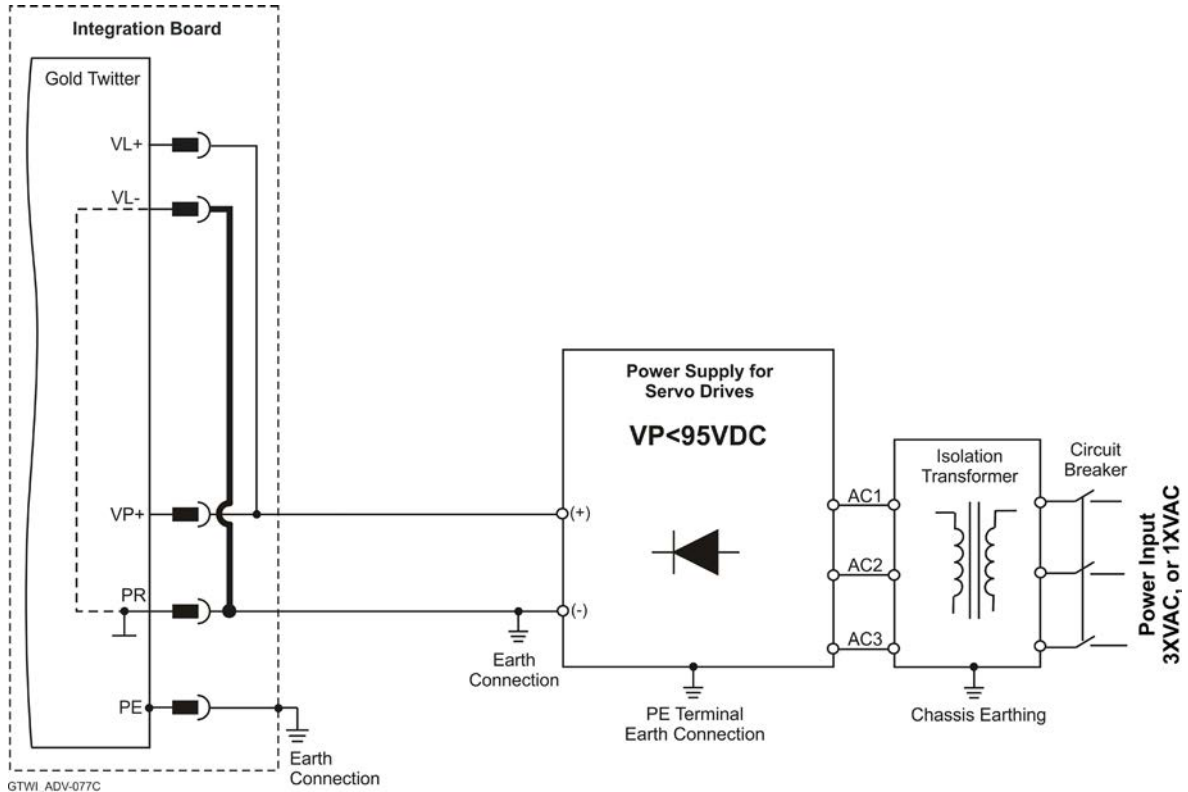

Figure 23: Recommended Single Power Supply (VP+ < 95V) Connection Diagram with VL+ Connected Internally

Note: This option is available for power supply up to 95VDC.

For applications where the recommended single power supply is used, the following conditions must apply:

- Minimum capacitance of the Power supply: $C_{Power_Supply} > Drive's\ Rated\ Current * 20\mu F$
- The VL- to PR is connected on the Integration Board (no external wiring)
- The VL- to PR connection must be as thick as possible, actually a Ground Plane is most preferable



10.2.4.2.2 SMPS Option

This option describes a main power and control topology without regeneration, but with limited Braking capabilities dependent on additional capacitance.

The C_{external} can be mounted on the Integration Board if there are no space limitations.

In the configuration of the 200V Gold Twitter model, the max operating voltage is 195VDC, but the DC bus must be limited to $VP+ < 95\text{VDC}$ to prevent failure of the VL supply.

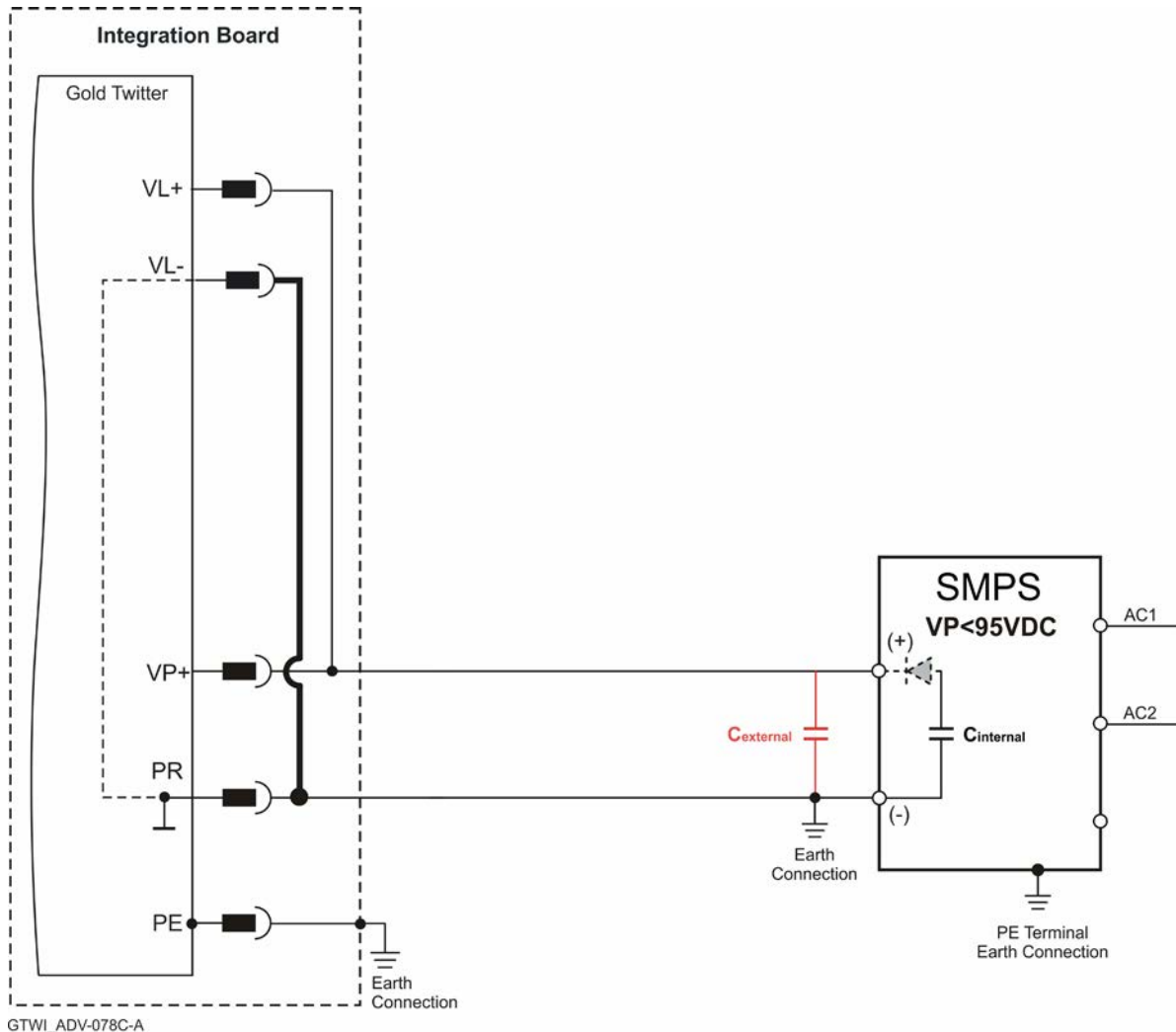

Figure 24: SMPS Single Power Supply ($VP+ < 95\text{V}$) Connection Diagram with VL+ Connected Internally

Note: This option is available for power supply up to 95VDC.

For applications where a SMPS single power supply is used, the following conditions must apply:

- External capacitance must be added on the DC bus
- The Minimum capacitance of the Power supply: $C_{\text{external}} > \text{“Drive’s Rated Current”} * 20\mu\text{F}$
- The VL- to PR is connected on the Integration Board (no external wiring)
- The VL- to PR connection must be as thick as possible, actually a “Ground Plane” is most preferable



10.2.4.2.3 Forbidden Option

Do NOT use the following wiring topology. Only connect the VL- to PR internally on the Integration Board.

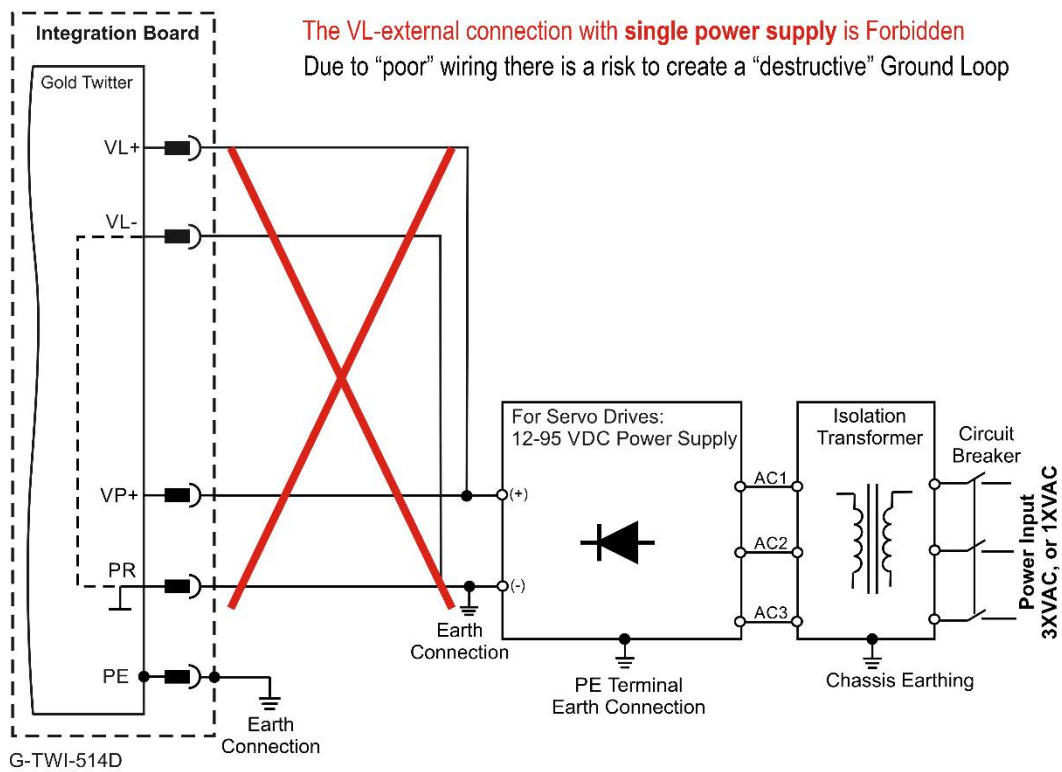
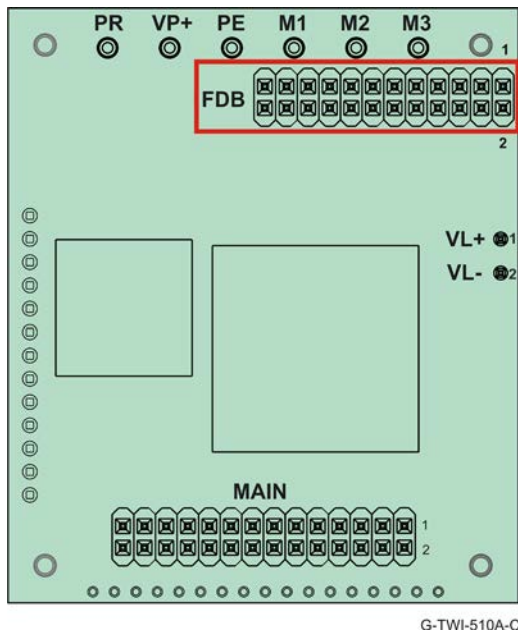

Figure 25: Forbidden Single Power Supply (<95V) Connection Diagram with VL+ Cable Connected Externally



10.3. Feedback Connector FDB



FDB Connector in the CAN option

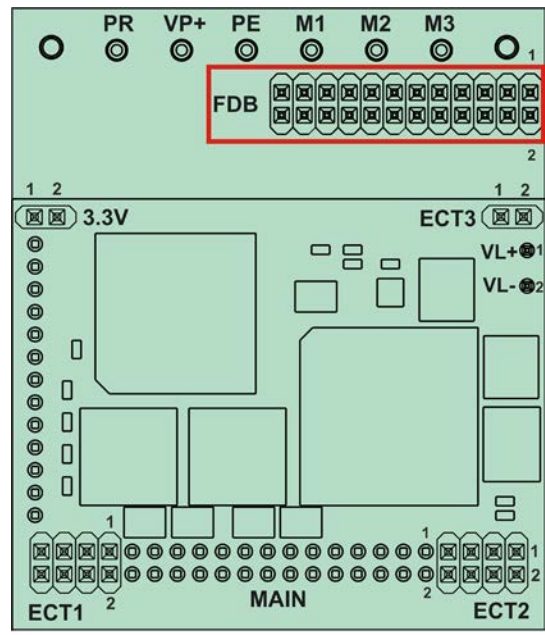

FDB Connector in the EtherCAT option

Feedback A/B/C, Digital Halls – see Section 9.2 in the manual: MAN-G-Board Level Modules Hardware Manual.

| Pin FDB | Signal | Function |
|---------|----------------------------|--|
| 1 | PortA_ENC_A+ /ABS_CLK+ | Port A- channel A/ Absolute encoder clock+ |
| 2 | PortB_ENC_A-/SIN- | Port B - channel A complement |
| 3 | PortA_ENC_A-/ABS_CLK- | Port A- channel A complement / Absolute encoder clock- |
| 4 | PortB_ENC_A+/SIN+ | Port B - channel A |
| 5 | PortA_ENC_B+/ABS_DATA+ | Port A - channel B/ Absolute encoder Data+ |
| 6 | PortB_ENC_B-/COS- | Port B - channel B complement |
| 7 | PortA_ENC_B-/ABS_DATA- | Port A - channel B complement / Absolute encoder Data- |
| 8 | PortB_ENC_B+/COS+ | Port B - channel B |
| 9 | PortA_ENC_INDEX+ | Port A – index |
| 10 | PortB_ENC_INDEX-/ANALOG_I- | Port B – index complement |
| | RESOLVER_OUT- | Vref complement |
| 11 | PortA_ENC_INDEX- | Port A - index complement |
| 12 | PortB_ENC_INDEX+/ANALOG_I+ | Port B – index |



| Pin FDB | Signal | Function |
|---------|-------------------|--------------------------------------|
| | RESOLVER_OUT+ | Vref |
| 13 | HA | Hall sensor A input |
| 14 | PortC_ENCO_A- | Port C- channel A complement output |
| 15 | HB | Hall sensor B input |
| 16 | PortC_ENCO_A+ | Port C- channel A output |
| 17 | HC | Hall sensor C input |
| 18 | PortC_ENCO_B- | Port C - channel B complement output |
| 19 | +5VE | Encoder +5 V supply @ Limit 200 mA |
| 20 | PortC_ENCO_B+ | Port C - channel B output |
| 21 | COMRET | Common return |
| 22 | PortC_ENCO_INDEX- | Port C - index complement output |
| 23 | COMRET | Common return |
| 24 | PortC_ENCO_INDEX+ | Port C - index output |

Table 8: Connector FDB – Feedback

For short distances between the drive and control, 0.5 to 1.0 m wires can be used and shielding is not required. For longer distances than 1.0 m and/or high EMI environment, shielded and twisted wires should be used. Drain wires should be connected to Elmo COMRET.



10.3.1. Port A

Refer to section 10.3 in the MAN-G-Board Level Modules Hardware Manual for further details of the Port A connections.

10.3.1.1. Incremental Encoder

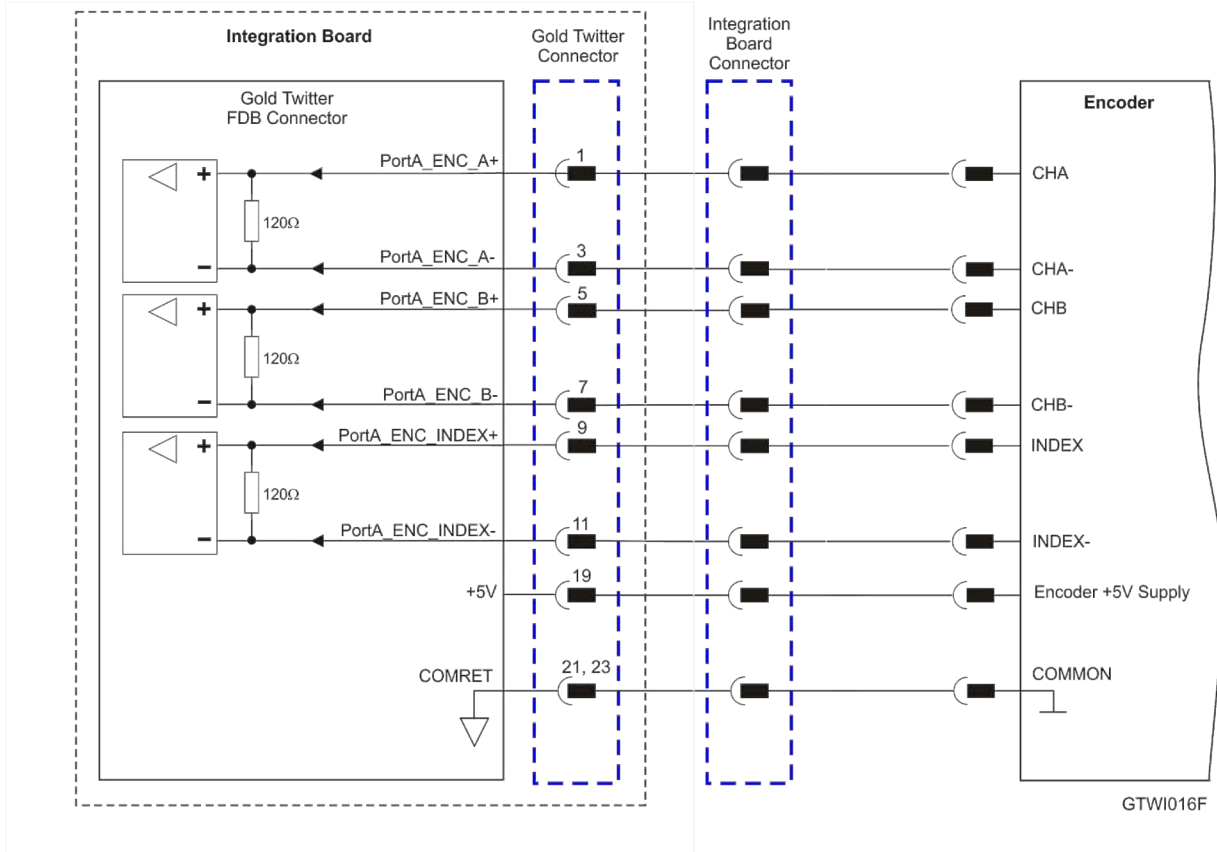

Figure 26: Port A Incremental Encoder Input – Recommended Connection Diagram

For short distances between the drive and control, 0.5 to 1.0 m wires can be used, and shielding is not required. For longer distances than 1.0 m and/or high EMI environment, shielded and twisted wires should be used. Drain wires should be connected to Elmo COMRET.



10.3.1.2. Absolute Serial Encoder

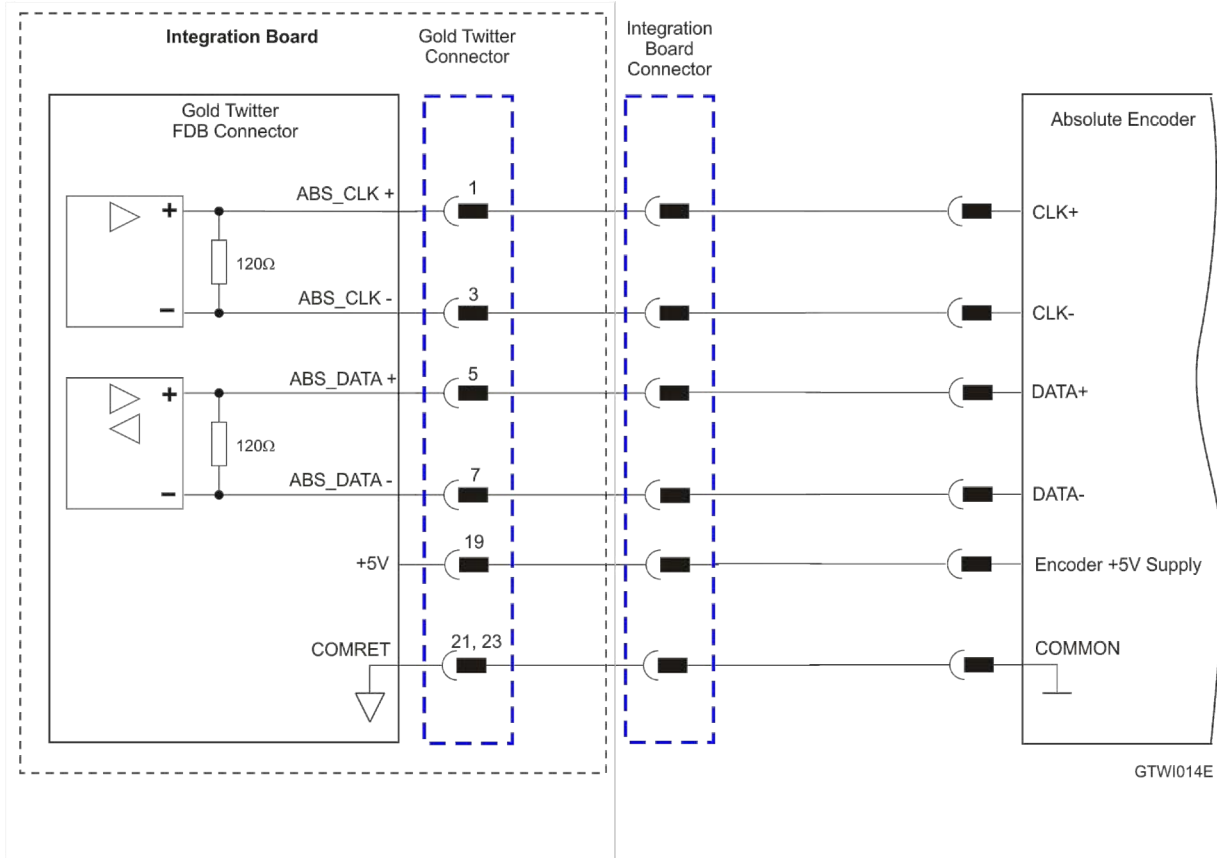

Figure 27: Absolute Serial Encoder – Recommended Connection Diagram for Sensors Supporting Data/Clock (e.g., Biss / SSI / EnDAT, etc.)

For short distances between the drive and control, 0.5 to 1.0 m wires can be used, and shielding is not required. For longer distances than 1.0 m and/or high EMI environment, shielded and twisted wires should be used. Drain wires should be connected to Elmo COMRET.

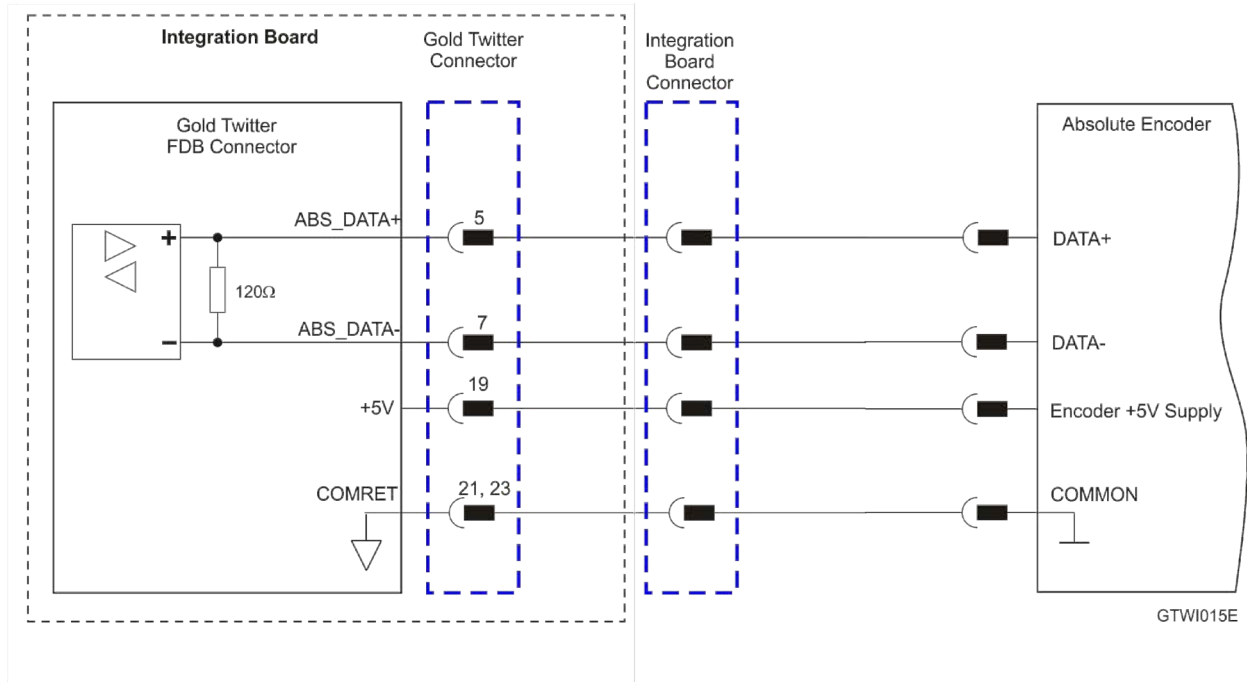

Figure 28: Absolute Serial Encoder – Recommended Connection Diagram for Sensors Supporting Data Line Only (NRZ types, e.g., Panasonic / Mitutoyo / etc.)

For short distances between the drive and control, 0.5 to 1.0 m wires can be used, and shielding is not required. For longer distances than 1.0 m and/or high EMI environment, shielded and twisted wires should be used. Drain wires should be connected to Elmo COMRET.



10.3.1.3. Hall Sensors

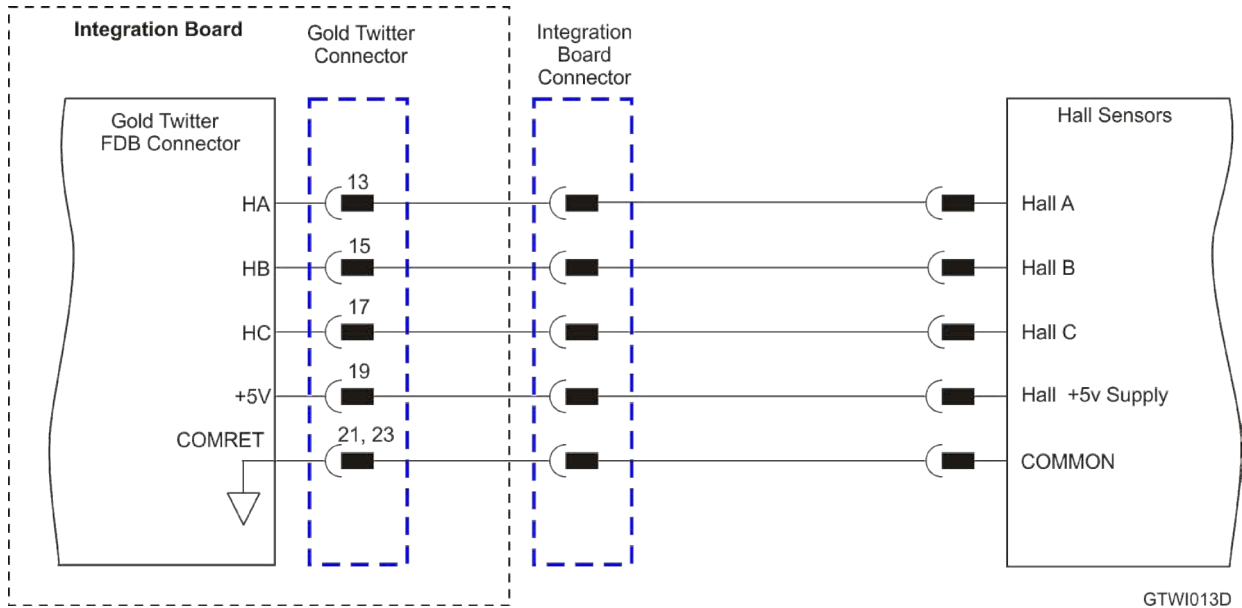

Figure 29: Hall Sensors Connection Diagram

For short distances between the drive and control, 0.5 to 1.0 m wires can be used, and shielding is not required. For longer distances than 1.0 m and/or high EMI environment, shielded and twisted wires should be used. Drain wires should be connected to Elmo COMRET.



10.3.2. Port B

Refer to section 10.4 in the MAN-G-Board Level Modules Hardware Manual for further details of the Port B connections.

10.3.2.1. Incremental Encoder

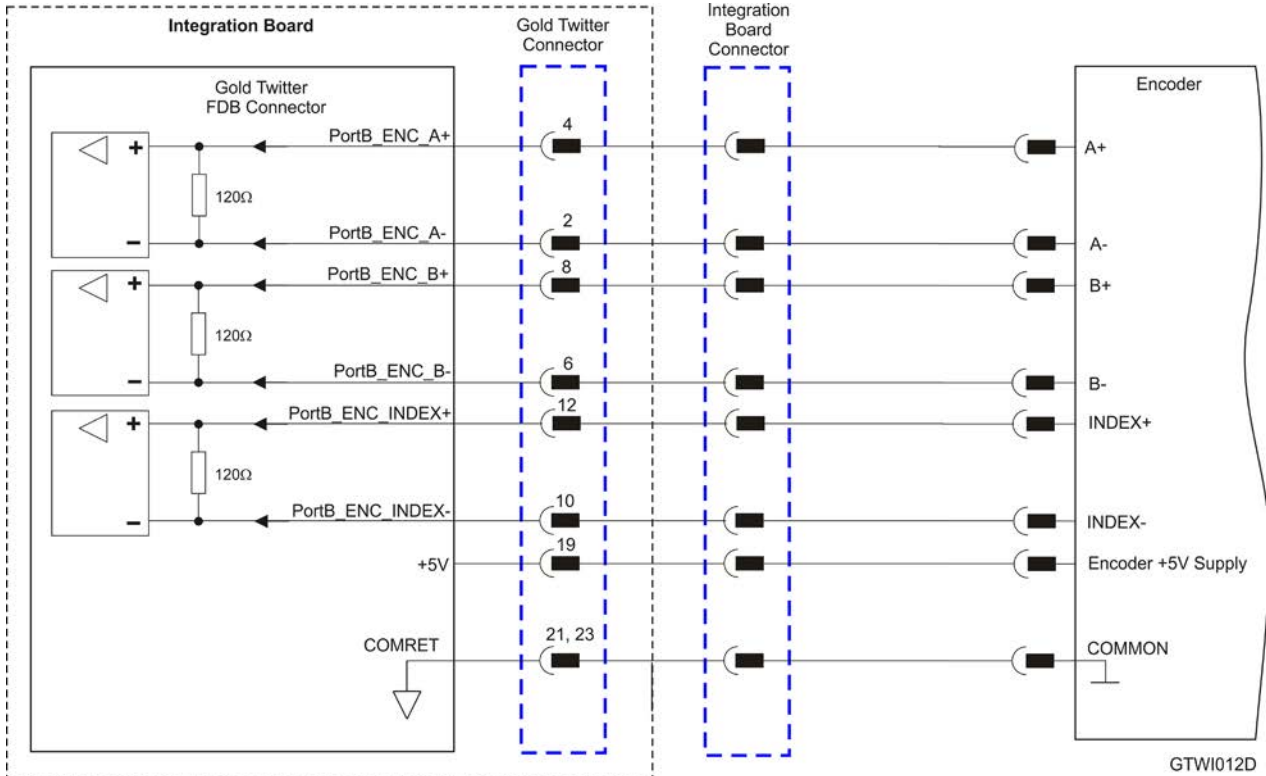

Figure 30: Port B Incremental Encoder Input – Recommended Connection Diagram

For short distances between the drive and control, 0.5 to 1.0 m wires can be used, and shielding is not required. For longer distances than 1.0 m and/or high EMI environment, shielded and twisted wires should be used. Drain wires should be connected to Elmo COMRET.



10.3.2.2. Interpolated Analog Encoder

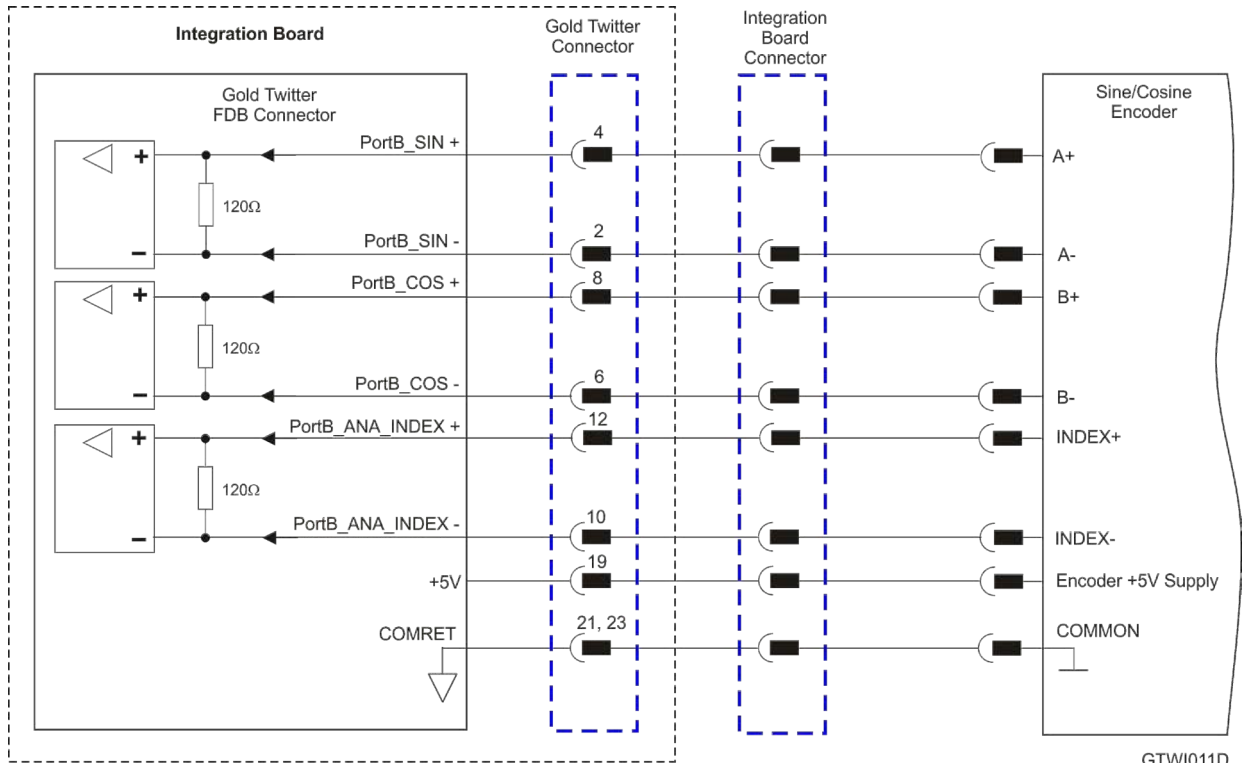
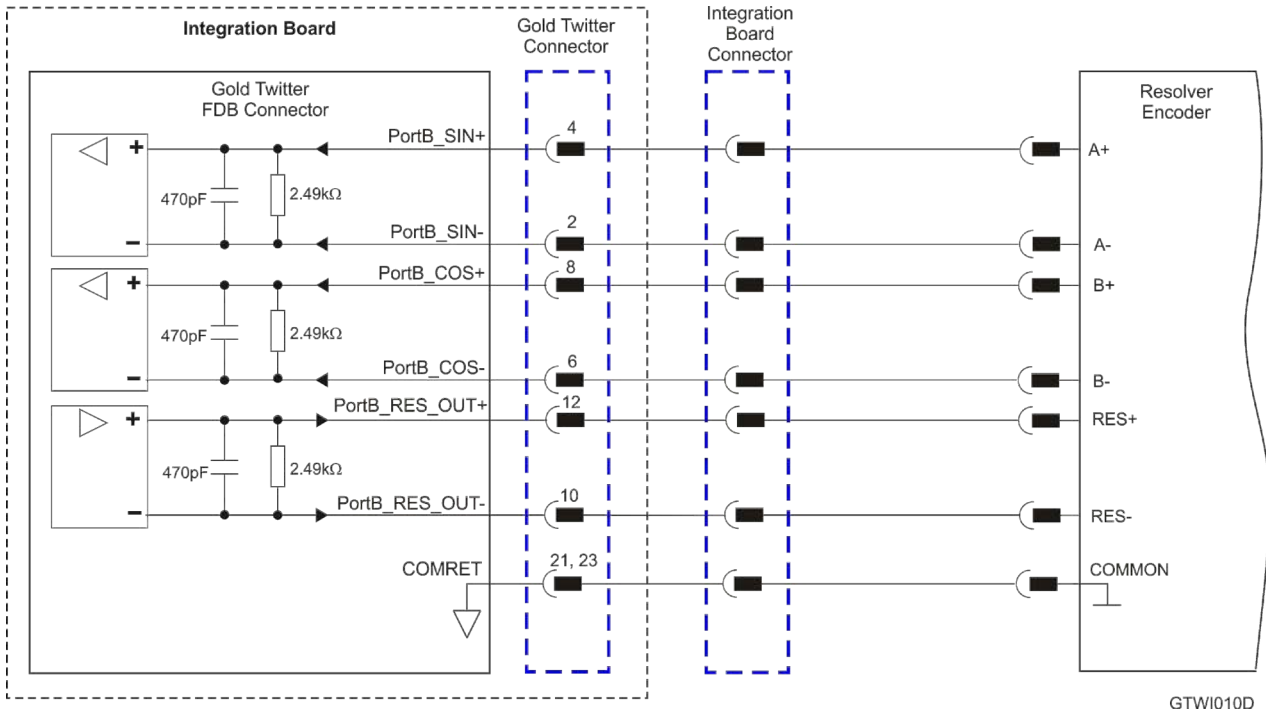

Figure 31: Port B - Interpolated Analog Encoder Connection Diagram

For short distances between the drive and control, 0.5 to 1.0 m wires can be used, and shielding is not required. For longer distances than 1.0 m and/or high EMI environment, shielded and twisted wires should be used. Drain wires should be connected to Elmo COMRET.



10.3.2.3. Resolver



GTWI010D

Figure 32: Port B – Resolver Connection Diagram

For short distances between the drive and control, 0.5 to 1.0 m wires can be used, and shielding is not required. For longer distances than 1.0 m and/or high EMI environment, shielded and twisted wires should be used. Drain wires should be connected to Elmo COMRET.



10.3.3. Port C – Emulated Encoder Output (FDB)

See Section 10.5 in the manual: MAN-G-Board Level Modules Hardware Manual for further details of Port C.

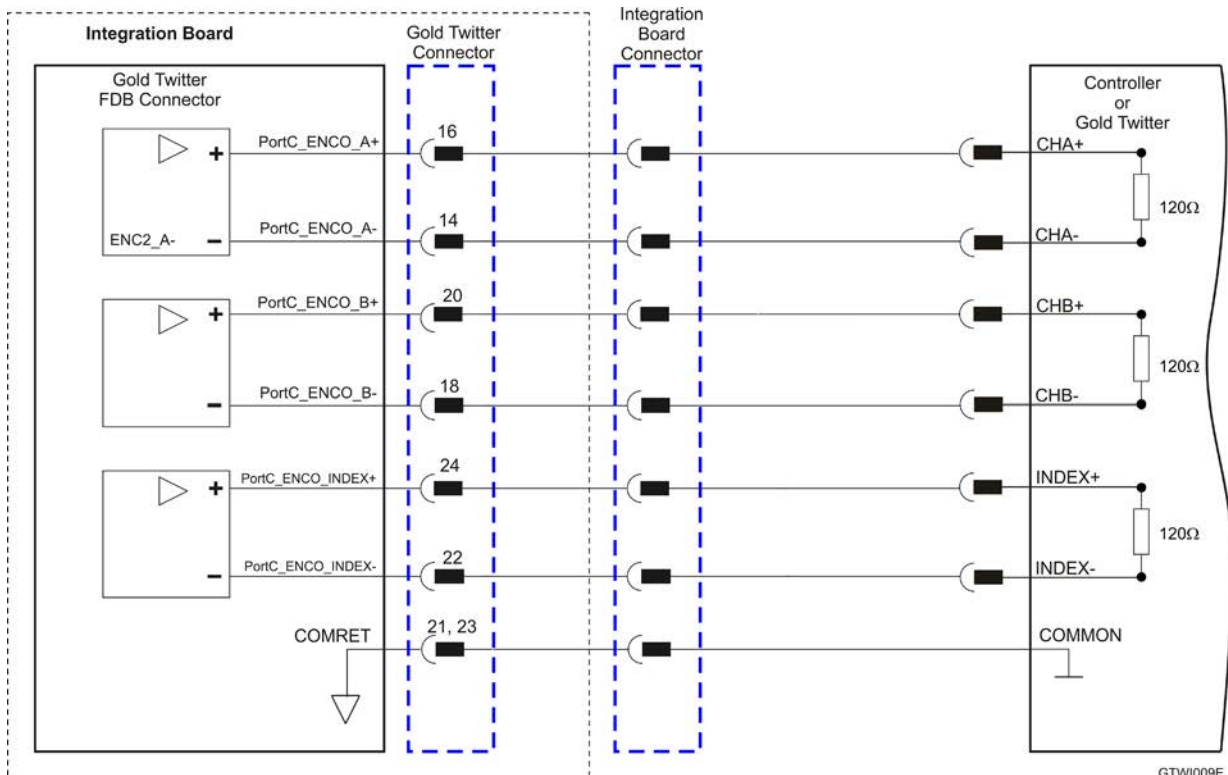
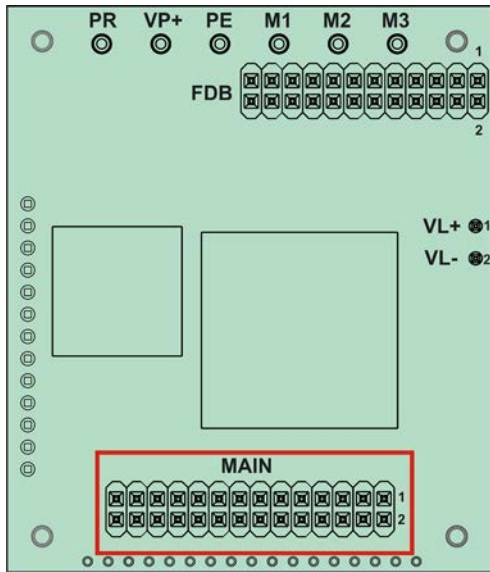

Figure 33: Emulated Encoder Differential Output – Recommended Connection Diagram

For short distances between the drive and control, 0.5 to 1.0 m wires can be used, and shielding is not required. For longer distances than 1.0 m and/or high EMI environment, shielded and twisted wires should be used. Drain wires should be connected to Elmo COMRET.



10.4. Main Connector (MAIN)



G-TWI-510A-D

FDB Connector in the CAN option

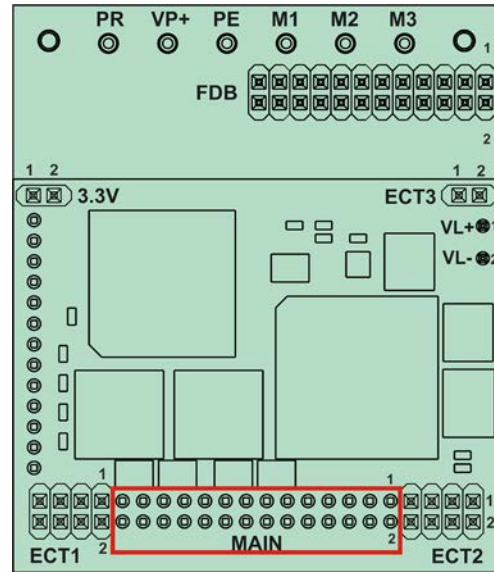

G-TWI-511A-B

FDB Connector in the EtherCAT option

| Pin (MAIN) | Signal | Function |
|------------|--------------------------|--|
| 1 | CAN Version: CANH | CAN Version: CAN_H BUS Line (dominant high) |
| | ECAT Version: LED_ET_ERR | ECT Version: EtherCAT status LED Error |
| 2 | CAN Version: CANL | CAN Version: CAN_L BUS Line (dominant low) |
| | ECAT Version: LED_ET_RUN | ECT Version: EtherCAT status LED Run |
| 3 | RS232_TX_S | Standard RS232 transmit |
| 4 | RS232_RX_S | Standard RS232 receive |
| 5 | RS232_TX /SB_IN | There are two options for this pin: Option 1: TTL RS232 transmit (Default) Option 2: Serial Bus IN for extended I/O (refer to MAN-G-Board Level Modules Hardware manual) This option is only available for EtherCAT |



| Pin (MAIN) | Signal | Function | |
|------------|------------------|---|---|
| 6 | RS232_RX /SB_OUT | <p>There are two options for this pin:</p> <p>Option 1: TTL RS232 receive (default)</p> <p>Option 2: Serial Bus output for extended I/O (refer to MAN-G-Board Level Modules Hardware manual) This option is only available for EtherCAT</p> | |
| 7 | COMRET | Common return | |
| 8 | COMRET | Common return | |
| 9 | ANALOG1+ | Analog input 1 | There is no ANARET (analog return) pin. Instead, the COMRET pin used. |
| 10 | ANALOG1- | Analog input 1 complement | |
| 11 | ANALOG_IN2 | Analog input 2 | |
| 12 | STO1 | STO 1 input, opto isolated from control (COMRET) | |
| 13 | STO_RET | <p>STO signal return.</p> <p>The two digital STO inputs are optically isolated from the other parts of the drive and share one return line.</p> | |
| 14 | STO2 | STO 2 input | |
| 15 | LED1 | Bi-color indication output 1 (Cathode) Internal Resistor 1K Ω | |
| 16 | LED2 | Bi-color indication output 2 (Cathode) Internal Resistor 1K Ω | |
| 17 | OUT4 | Programmable output 4 (connected to COMRET) (3.3V logic level) | |
| 18 | OUT2 | Programmable output 2 (connected to COMRET) (5V logic level) | |
| 19 | OUT3 | Programmable output 3 (connected to COMRET) (3.3V logic level) | |
| 20 | OUT1 | Programmable output 1 (connected to COMRET) (5V logic level) | |
| 21 | COMRET | Common return | |
| 22 | COMRET | Common return | |
| 23 | IN6 | Programmable digital input 6 (connected to COMRET) (5V logic level) | |



| Pin (MAIN) | Signal | Function |
|------------|--------|---|
| 24 | IN5 | Programmable digital input 5 (connected to COMRET) (5V logic level) |
| 25 | IN4 | Programmable digital input (connected to COMRET) (5V logic level) |
| 26 | IN3 | Programmable digital input 3 (connected to COMRET) (5V logic level) |
| 27 | IN2 | Programmable digital input 2 (connected to COMRET) (5V logic level) |
| 28 | IN1 | Programmable digital input 1 (connected to COMRET) (5V logic level) |

Table 9: Connector MAIN – I/O, STO, Analog, LEDs

LEDs

For full details on the LEDs, see Chapter 7, and section 12.2.1 in the in the MAN-G-Board Level Modules Hardware manual for full details.

STO (safety)

For full details on STO, see Chapter 9 in the in the MAN-G-Board Level Modules Hardware manual for full details.

For RS232, and Analog Input Wires

For short distances between the drive and control, 0.5 to 1.0 m wires can be used, and shielding is not required. For longer distances than 1.0 m and/or high EMI environment, shielded and twisted wires should be used. Drain wires should be connected to Elmo COMRET.

For Digital Inputs/Outputs, STO

Wires can be always used, no need for twisting, no need for shielding.

For CAN Communication

Always use CAT5e cables.



10.4.1. Digital Inputs

The following table describes the electrical specification of the inputs IN1 and IN6:

| Feature | Details |
|--|---|
| Input Voltage (VIN) | 0 to 6V |
| V _{ih} min | 2.2V |
| V _{il} max | 0.6V |
| R ₁ Pull-up Resistor | If VT = 3.3V, R1<3.3KΩ If VT = 5V, R1<10KΩ |
| Minimum pulse width | > 250 μsec |
| Execution time (all inputs): the time from application of voltage on input until execution is complete | 0 < T < 250 μsec |
| High-speed inputs – 1–6 minimum pulse width, in high-speed mode | T = 5 μsec if the input functionality is set to latch/capture (index/strobe). Note: Home mode is high-speed mode and can be used for fast capture and precise homing. |
| Capture with differential input Port A, Port B Index | T > 0.1 μsec if the differential input functionality is set to touch probe/capture (index/strobe). |

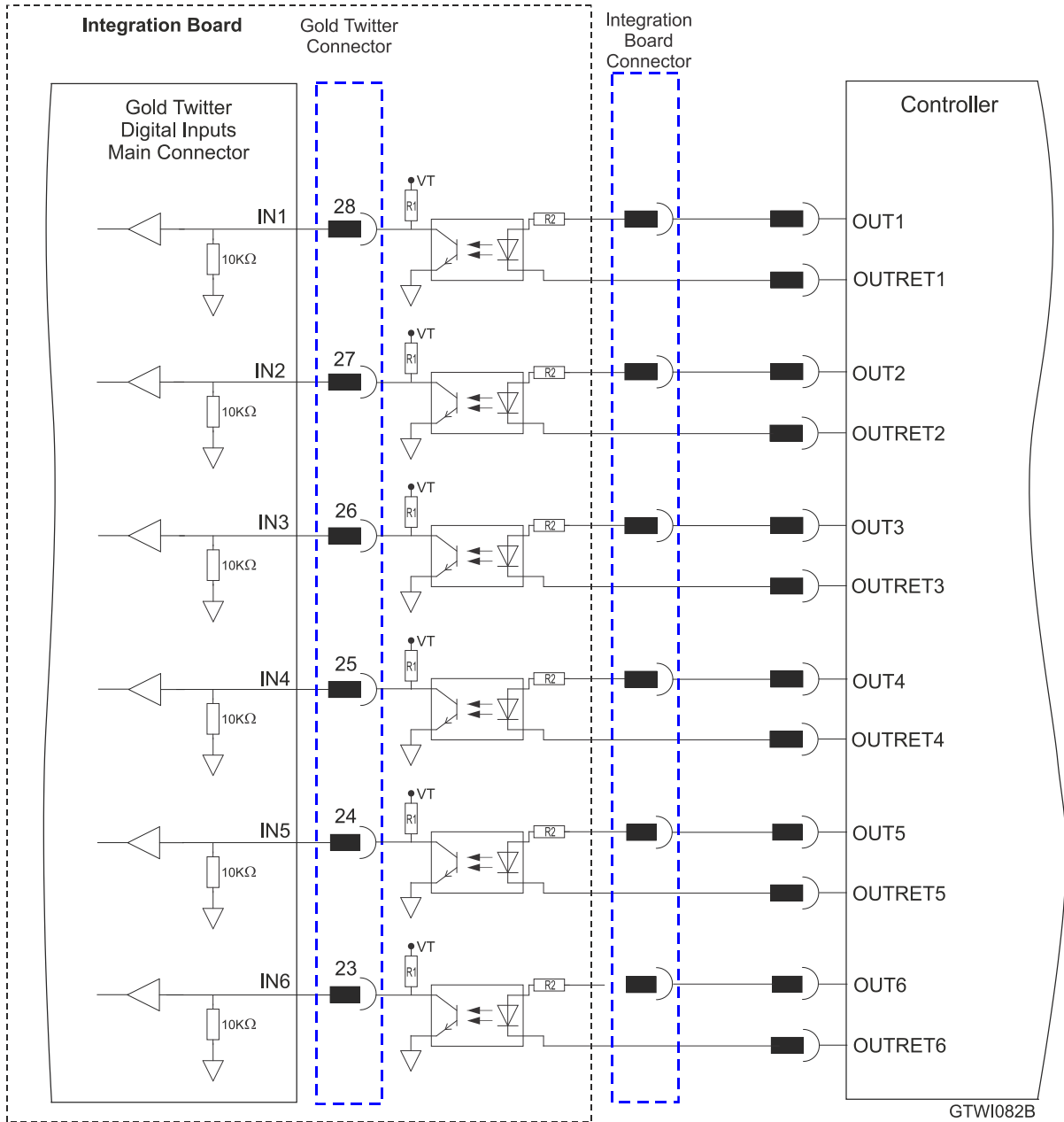

Figure 34: Digital Input 5V Logic level Mode Connection Diagram



10.4.2. Digital Outputs

There are two types of Digital outputs:

- Out1 and Out2 5V Logic
- Out3 and Out4 3.3V Logic

The following table describes the electrical specification of the outputs OUT1 and OUT2:

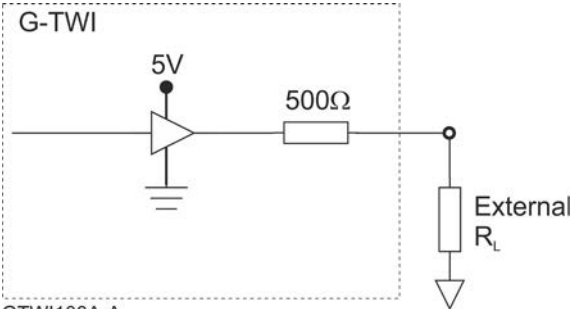
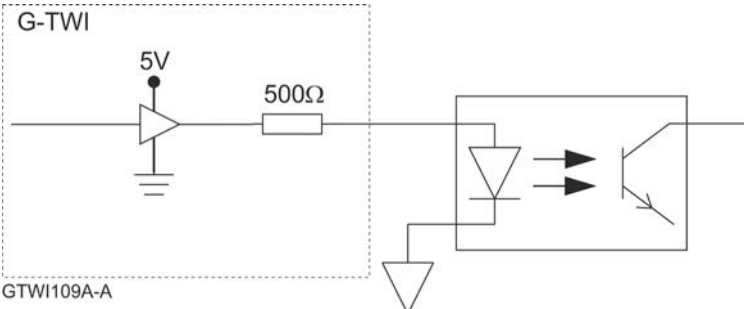
| Feature | Details |
|--|---|
| Type of output | 5V Logic |
| Output Configuration |  <p>GTWI108A-A</p> |
| V_{OL} max of TTL Buffer (low level) | $V_{out} (Low) \leq 0.44V @ 8mA$ |
| V_{OH} min of TTL Buffer (High level) | $V_{out} (High) > 4.4V @ 8mA$ |
| Output current | $I_{out(max)} = \frac{5V}{500\Omega + R_L (external)}$ <p>Where:</p> $V_{R_L(High)} = 5V - 500 * I_{out(max)}$ |
| Example of connection to the opto-couplers |  <p>GTWI109A-A</p> <p>Where:</p> $I_{out(max)} = \frac{5V - 2.0V}{500\Omega} = 6.0mA$ |
| T_{on} (time from low to high) | <1μsec |
| T_{off} (time from high to low) | <1μsec |
| Executable time | $0 < T < 250 \mu sec$ |

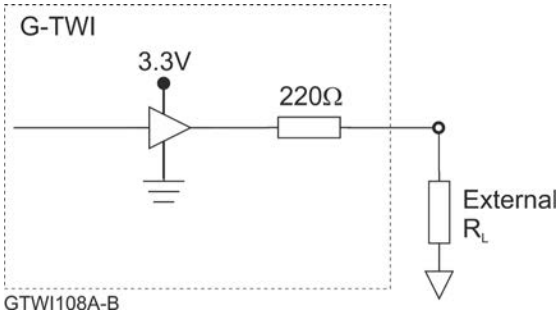
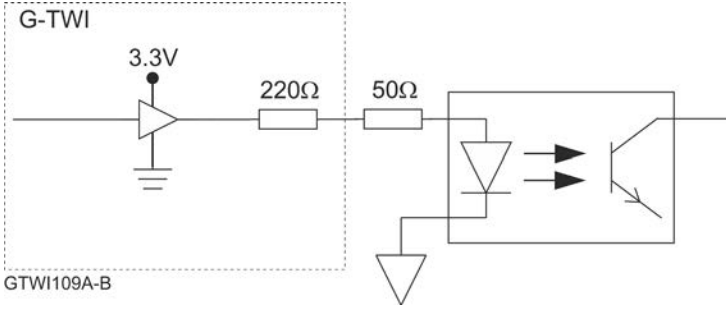

The following table describes the electrical specification of the outputs OUT3 and OUT4.

| Feature | Details |
|--|---|
| Type of output | 3.3V Logic |
| Output Configuration |  |
| V_{OL} max of TTL buffer (low level) | $V_{out} (On) \leq 0.4V @ 8mA$ |
| V_{OH} min of TTL buffer (High level) | $V_{out} (High) > 2.9V @ 8mA$ |
| Output current | $I_{out(max)} = \frac{3.3V}{220\Omega + R_{L (external)}}$ <p>Where:</p> $V_{R_{L (High)}} = 3.3V - 220 * I_{out(max)}$ |
| Example of connection to the opto-couplers |  <p>Where:</p> $I_{out(max)} = \frac{3.3V - 2.0V}{220\Omega + 50\Omega} = 4.8 mA$ |
| T_{on} (time from low to high) | <1usec |
| T_{off} (time from high to low) | <1usec |
| Executable time | $0 < T < 250 \mu sec$ |

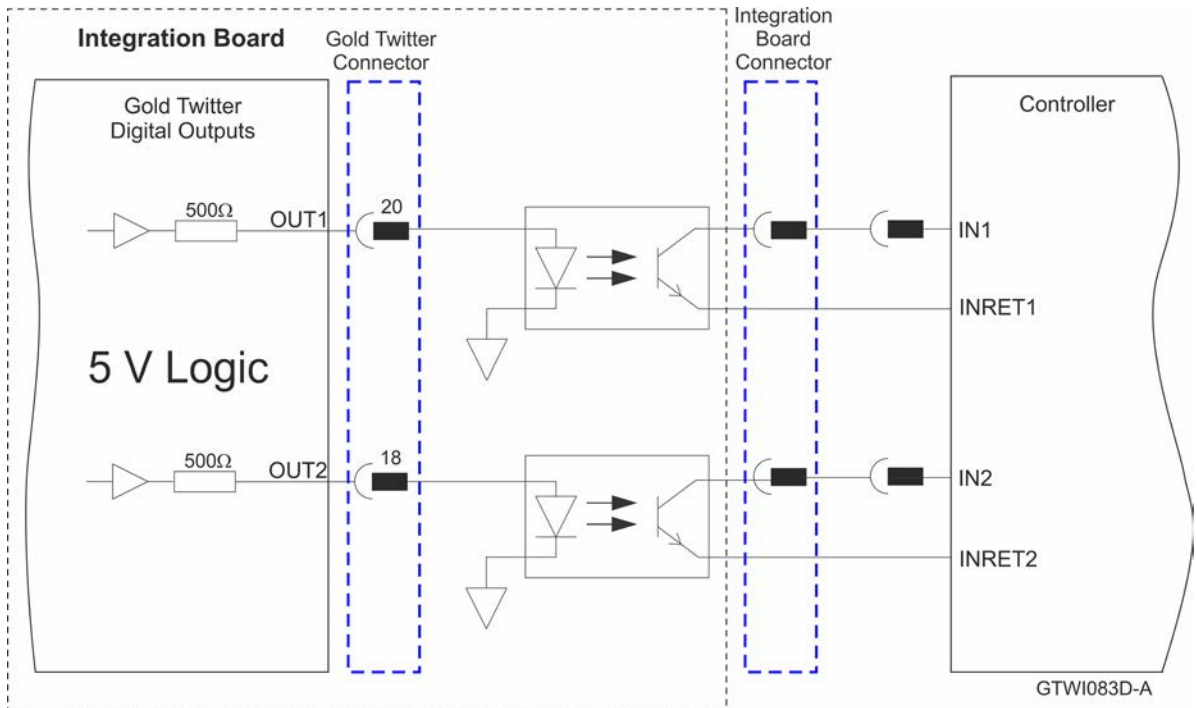

Figure 35: Digital Output 5V Logic Mode Connection Diagram

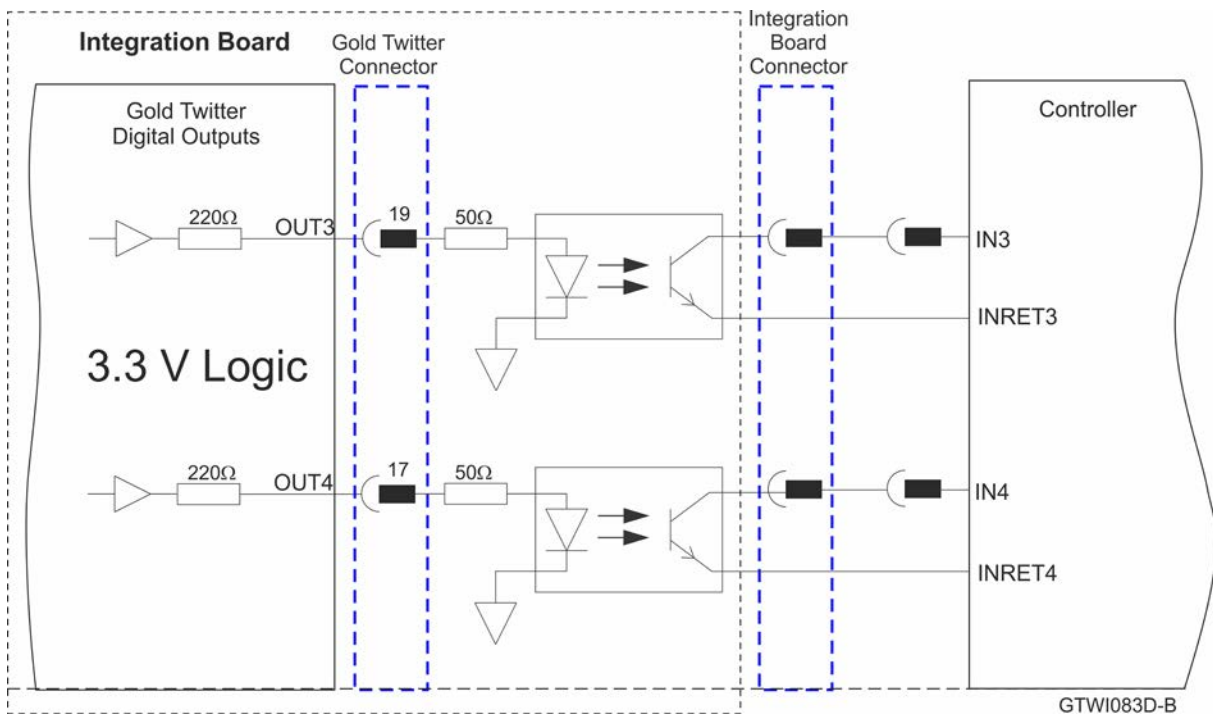

Figure 36: Digital Output 3.3V Logic Mode Connection Diagram



10.4.3. STO (Safe Torque Off)

For full details on STO, see Chapter 9 in the MAN-G-Board Level Modules Hardware manual.

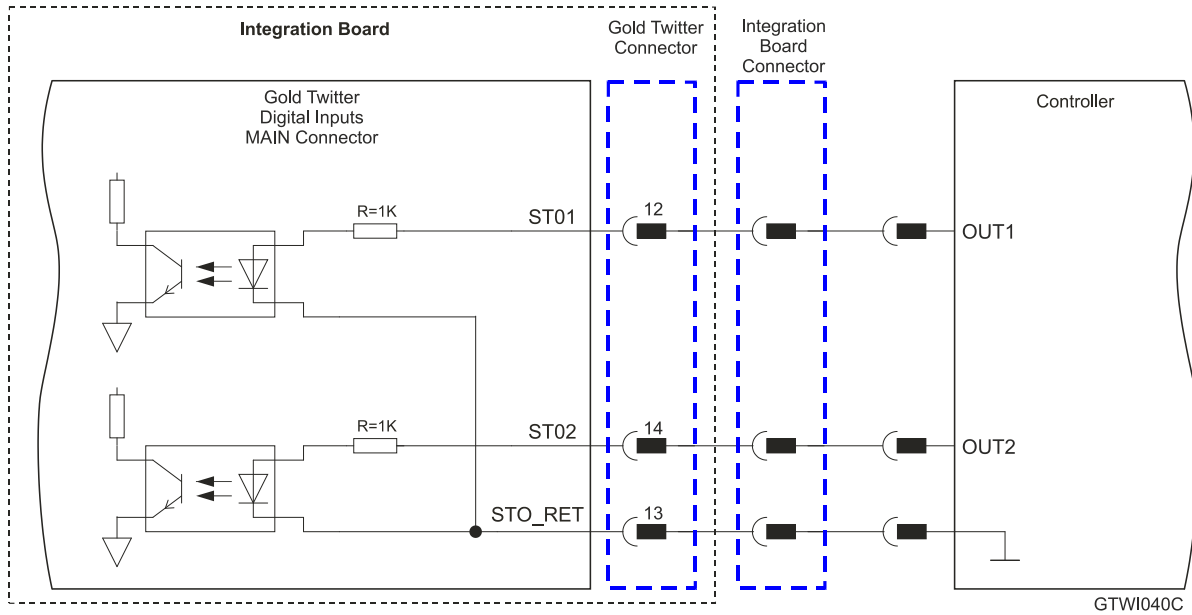

Figure 37: STO Input Connection – 5V Logic Level

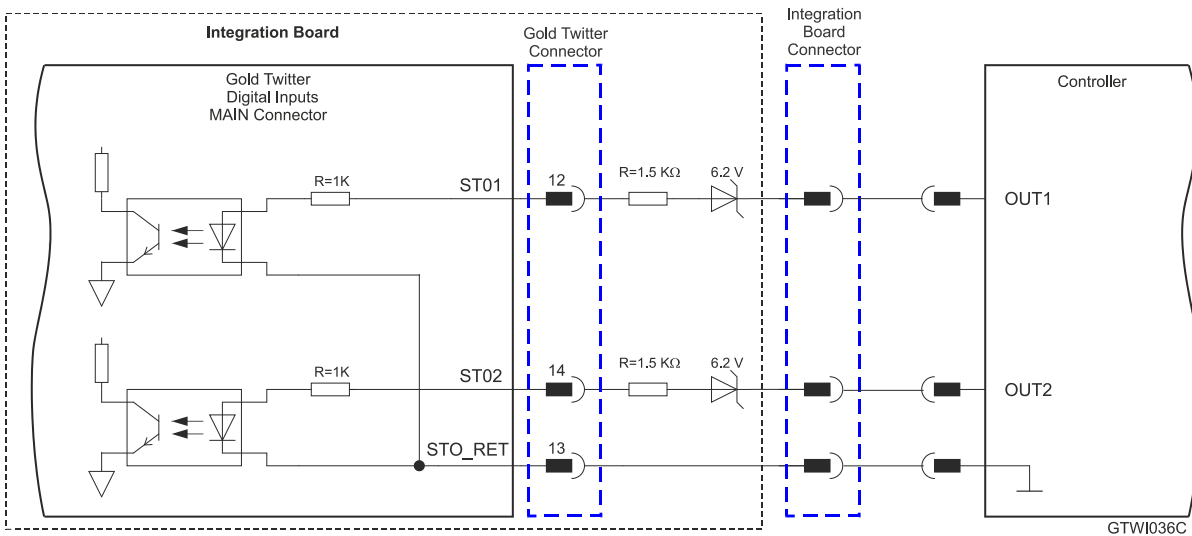

Figure 38: STO Input Connection – PLC (24V Logic)



10.4.4. Analog Input

For full details on Analog Inputs, see section 11.3 in the MAN-G-Board Level Modules Hardware manual.

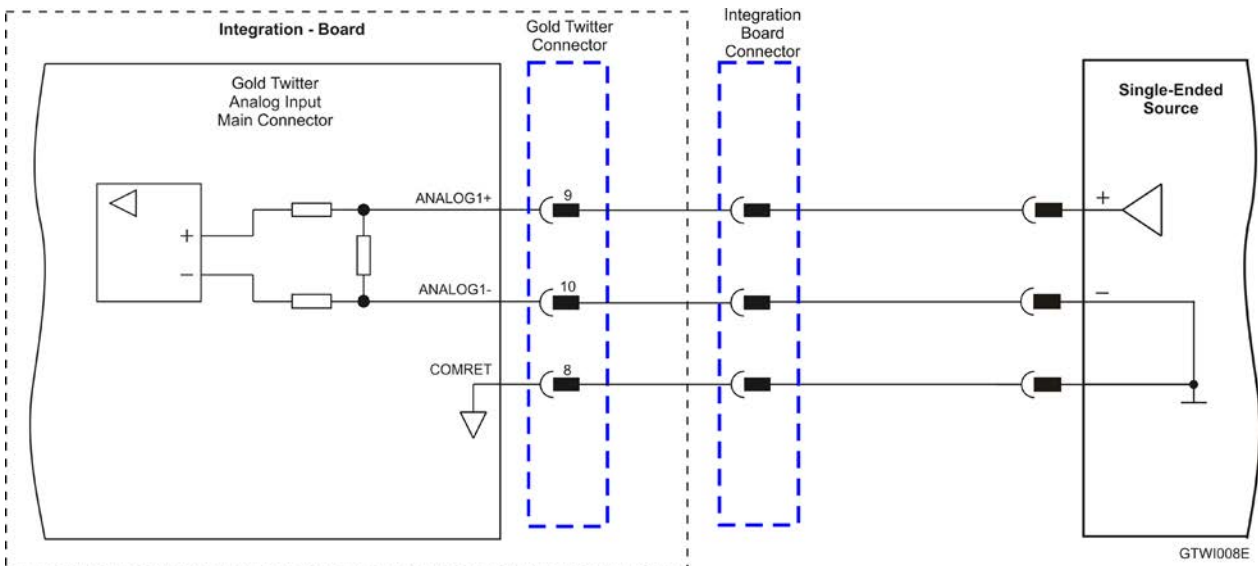

Figure 39: Analog Input

For short distances between the drive and control, 0.5 to 1.0 m wires can be used, and shielding is not required. For longer distances than 1.0 m and/or high EMI environment, shielded and twisted wires should be used. Drain wires should be connected to Elmo COMRET.



10.4.5. CAN Option

For full details on CANopen communication, see section 14.3 in the MAN-G-Board Level Modules Hardware manual.

10.4.5.1. Interface

The PCB-Mounted Module includes the CAN transceiver and mode choke. Therefore, it is required to add a CAN Bus Protector for ESD and other harmful transient voltage events.

The following signals describe how to connect CAN to the external connector.

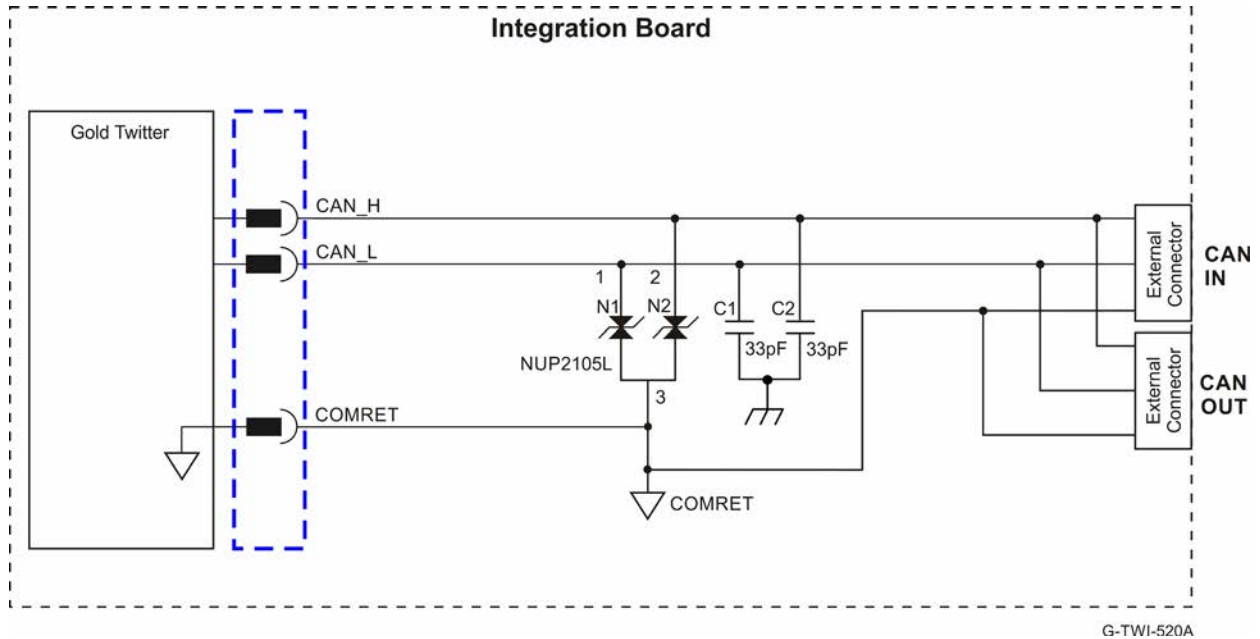

Figure 40: CAN Interface

The following are examples of the components described in Figure 40.

| Interface Components | Part | P/N |
|--|----------|----------------|
| 33PF/50V,NPO,10% | AVX | 06035A330JAT1A |
| DUAL BIDIRECTIONAL VOLTAGE SUPPRESSOR,NUP2105L | ON SEMIC | NUP2105LT1G |



10.4.5.2. CAN Layout

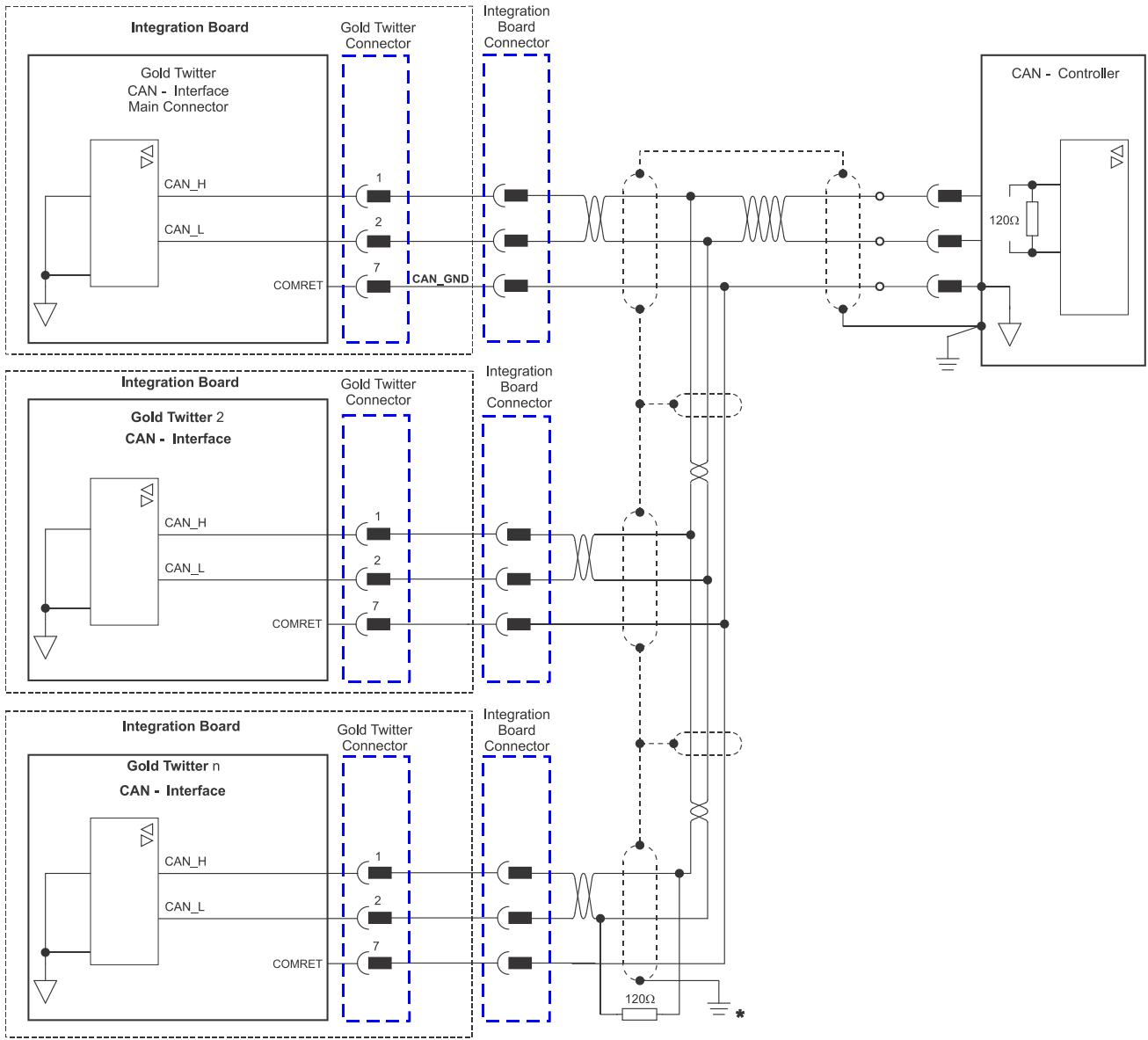

GTWI018D

* Note: If cable is long (>5M) it is recommended to ground at both ends

Figure 41: CAN Network Diagram



Caution: When installing CAN communication, ensure that each servo drive is allocated a unique ID. Otherwise, the CAN network may “hang”.

Note: Always use CAT5e cables.



10.4.6. RS232

There are two types of RS232: Standard RS232 and RS232 TTL Level.

Figure 42 describes the Standard RS232 connection diagram.

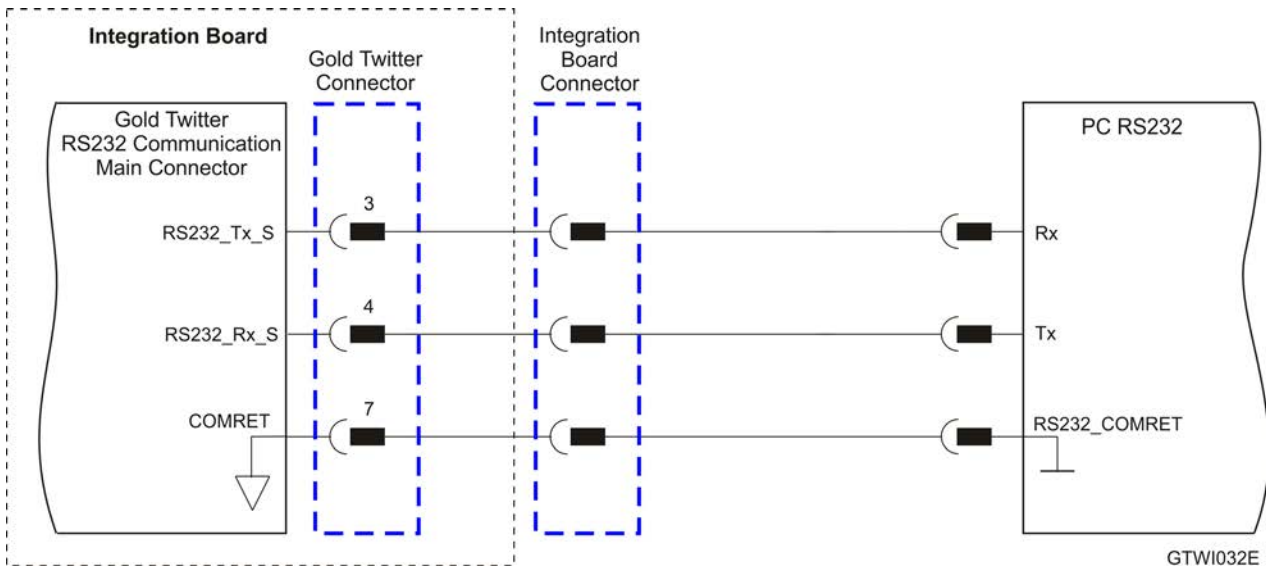

Figure 42: RS232 Connection Diagram

For full details on RS232 TTL Level communication, see section 12.5.1 in the MAN-G-Board Level Modules Hardware manual.

For short distances between the drive and control, 0.5 to 1.0 m wires can be used, and shielding is not required. For longer distances than 1.0 m and/or high EMI environment, shielded and twisted wires should be used. Drain wires should be connected to Elmo COMRET.



The RS232 TTL Level will be used in order to connect Differential RS232 (RS422).

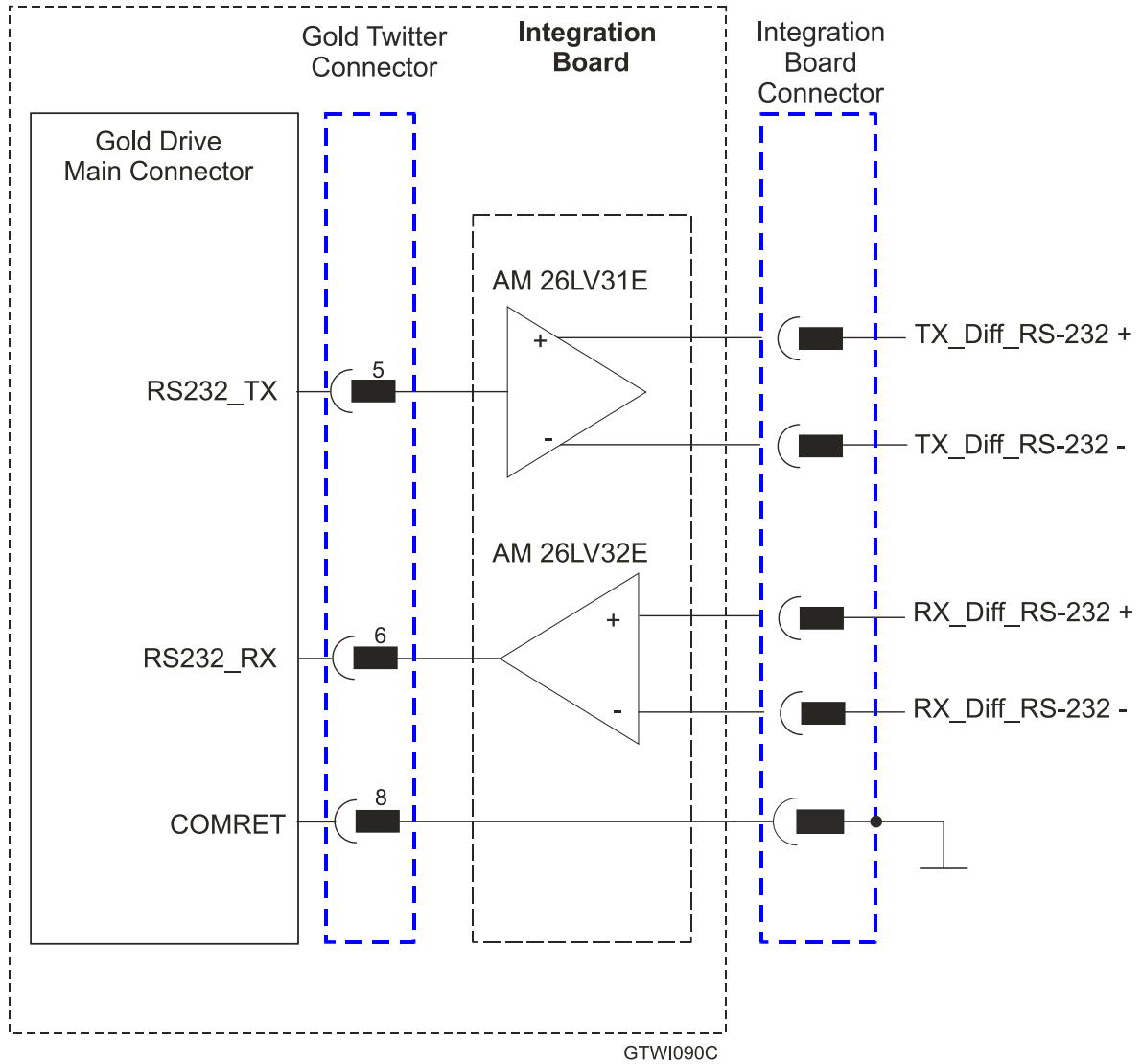
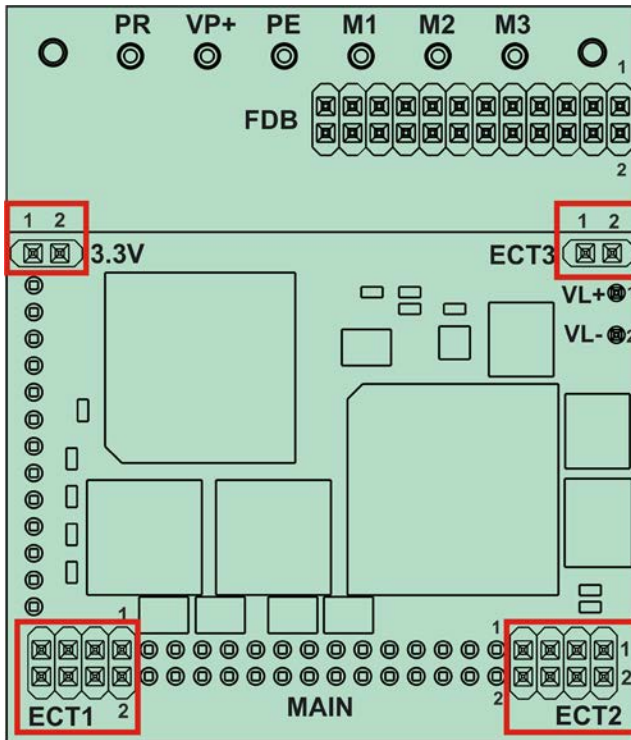

Figure 43: Differential RS232 (RS422) Connection Diagram



10.5. EtherCAT Module



For full details on EtherCAT communication, see Section 12.2 in the in the MAN-G-Board Level Modules Hardware manual.

10.5.1. EtherCAT Module Connectors

10.5.1.1. ECT2 connector

| Pin (ECT2) | Signal | Function |
|------------|------------------|--|
| 1 | USB_VBUS | USB VBUS 5V Detector |
| 2 | USBD+ | USB_P line |
| 3 | COMRET | USB communication return |
| 4 | USBD- | USB_N line |
| 5 | PHY_IN_LINK_ACT | Indicates EtherCAT IN/Ethernet LINK input |
| 6 | PHY_OUT_LINK_ACT | Indicates EtherCAT OUT LINK |
| 7 | PHY_IN_SPEED | Indicates EtherCAT IN/Ethernet Speed input |
| 8 | PHY_OUT_SPEED | Indicates EtherCAT OUT Speed |

Table 10: Connector ECT2

For USB Wires

For short distances between the drive and control, 0.5 to 1.0 m wires can be used, and shielding is not required. For longer distances than 1.0 m and/or high EMI environment, shielded and twisted wires should be used. Drain wires should be connected to Elmo COMRET.

**10.5.1.2. ECT1 connector**

| Pin (ECT1) | Signal | Function |
|------------|-------------|--------------------------------|
| 1 | PHY_OUT_RX+ | EtherCAT OUT RX+ Line |
| 2 | PHY_OUT_TX+ | EtherCAT OUT TX+ Line |
| 3 | PHY_OUT_RX- | EtherCAT OUT RX- Line |
| 4 | PHY_OUT_TX- | EtherCAT OUT TX- Line |
| 5 | PHY_IN_RX+ | EtherCAT IN/Ethernet RX+ Line |
| 6 | PHY_IN_TX+ | EtherCAT IN/Ethernet TX+ Line |
| 7 | PHY_IN_RX- | EtherCAT IN/ Ethernet RX- Line |
| 8 | PHY_IN_TX- | EtherCAT IN/Ethernet TX- Line |

Table 11: Connector ECT1

Note: EtherCAT IN port can be configured to an Ethernet Port.

Note: Always use CAT5e cables.

10.5.1.3. ECT3 Connector

| Pin (ECT3) | Signal | Function |
|------------|----------|---|
| 1 | SB_Clock | Serial Bus_Clock (9.375Mhz) for extended IO (refer to the MAN-G-Panel Mounted Drives Hardware Manual) |
| 2 | SB_Load | Serial Bus Load for extended IO (refer to the MAN-G-Panel Mounted Drives Hardware Manual) |

Table 12: Connector ECT3**10.5.1.4. 3.3V Connector**

| Pin | Signal | Function |
|-----|--------|--|
| 1 | 3.3V | 3.3 V supply voltage for EtherCAT LEDs |
| 2 | 3.3V | 3.3 V supply voltage for EtherCAT LEDs |

Table 13: 3.3V Connector



10.5.2. EtherCAT Communication

This section only describes the EtherCAT communication, and the pinout drawing of the connector.



When the EtherCAT is connected and the FoE is in operation, the USB cable connection must be disconnected.

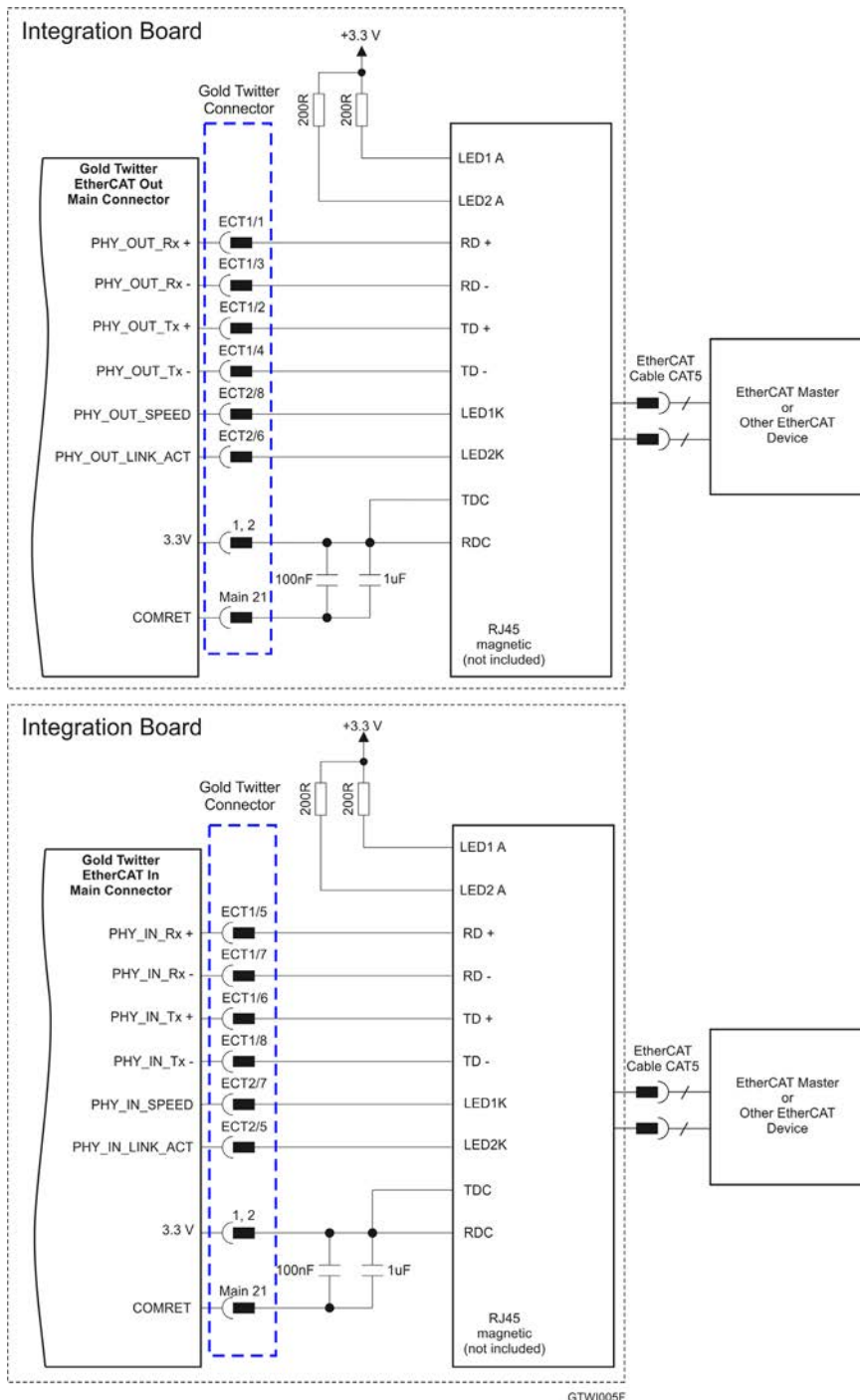

Figure 44: EtherCAT Connection Schematic Diagram

Note: Always use CAT5e cables.



10.5.3. USB 2.0 Communication (for EtherCAT model only)

For full details on USB communication, see section 12.1 in the MAN-G-Board Level Modules Hardware manual.

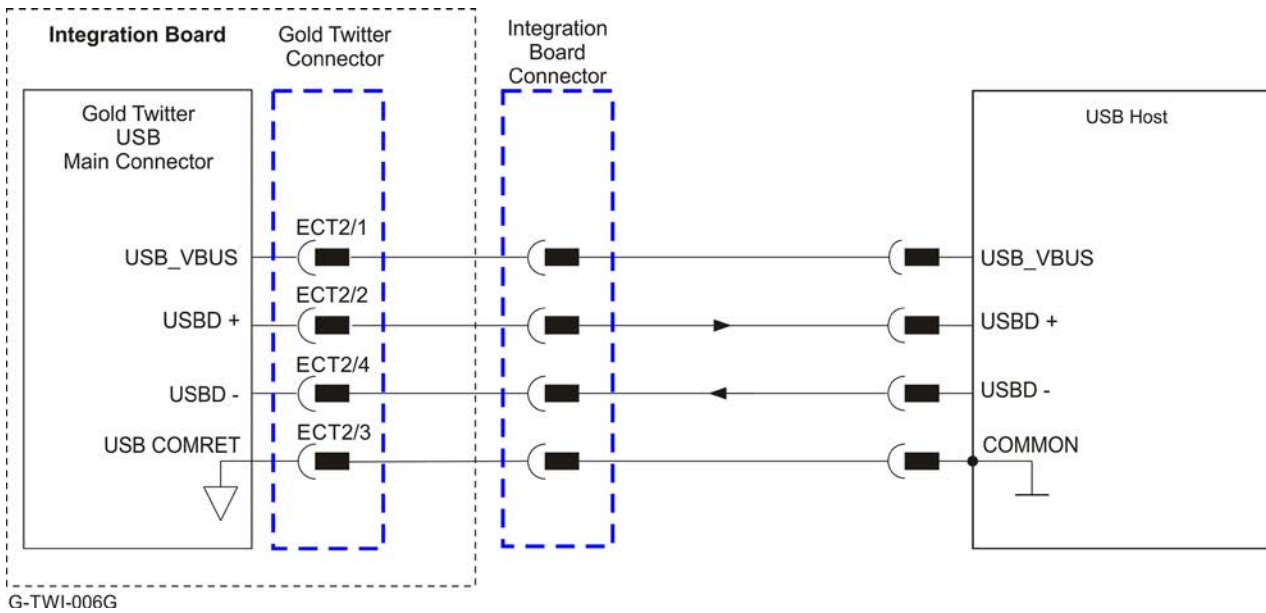

Figure 45: USB Network Diagram

For short distances between the drive and control, 0.5 to 1.0 m wires can be used and shielding is not required. For longer distances than 1.0 m and/or high EMI environment, shielded and twisted wires should be used. Drain wires should be connected to Elmo COMRET.



Chapter 11: Powering Up

After the Gold Twitter is connected to its device, it is ready to be powered up.



Caution:

Before applying power, ensure that the DC supply is within the specified range and that the proper plus-minus connections are in order.

11.1. Initializing the System

After the Gold Twitter has been connected and mounted, the system must be set up and initialized. This is accomplished using the *EASII*, Elmo's Windows-based software application. Install the application and then perform setup and initialization according to the directions in the *EASII User Manual*.

11.2. Heat Dissipation

The best way to dissipate heat from the Gold Twitter is to mount it so that its heat-sink is attached to the machine chassis. If mounted with its heat-sink suspended, then for best results mount the servo drive faced upwards and leave approximately 10 mm of space between the Gold Twitter's heat-sink and any other assembly.

11.2.1. Heat Dissipation Data

Heat Dissipation is shown graphically below. **It should be noted in the graphs below that the Flat Heat Sink and Fins Heat Sink can dissipate up to 5.5W and 7.0W respectively:**

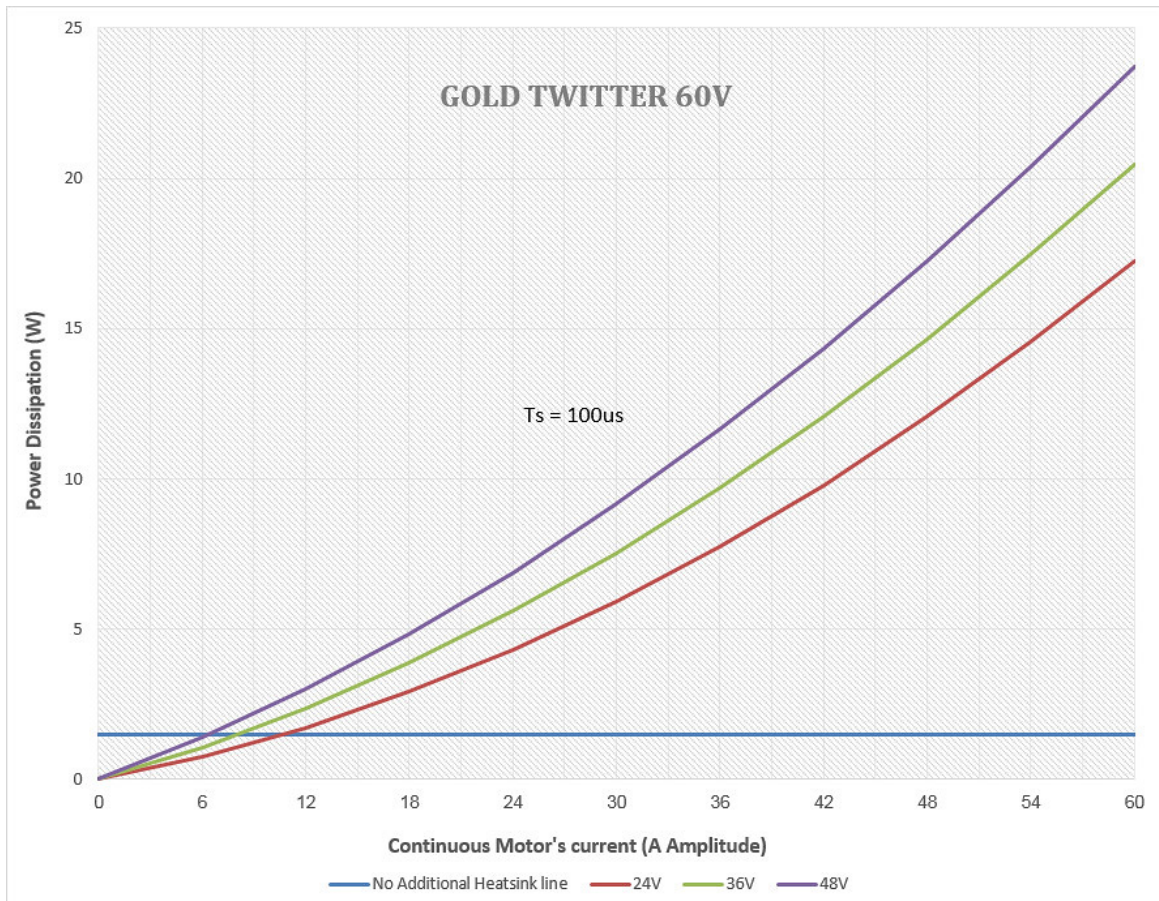

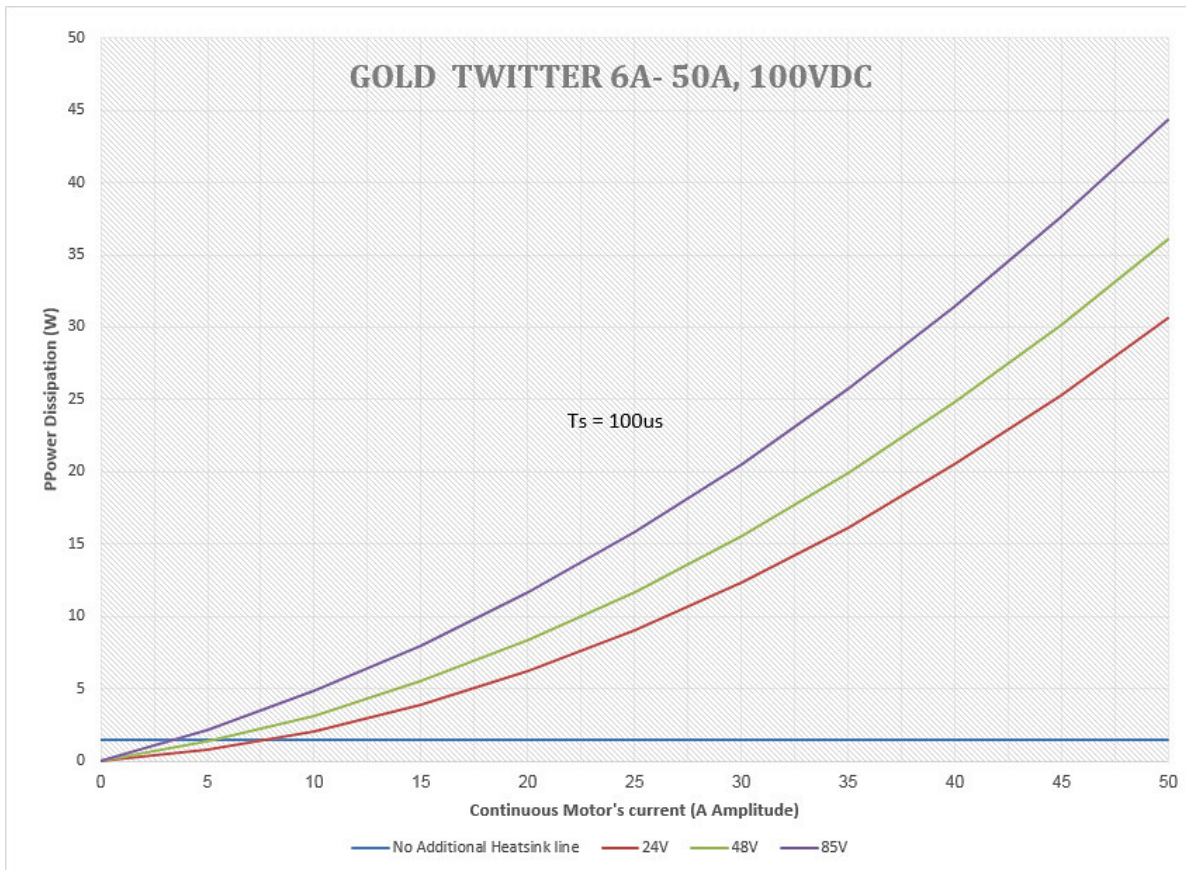
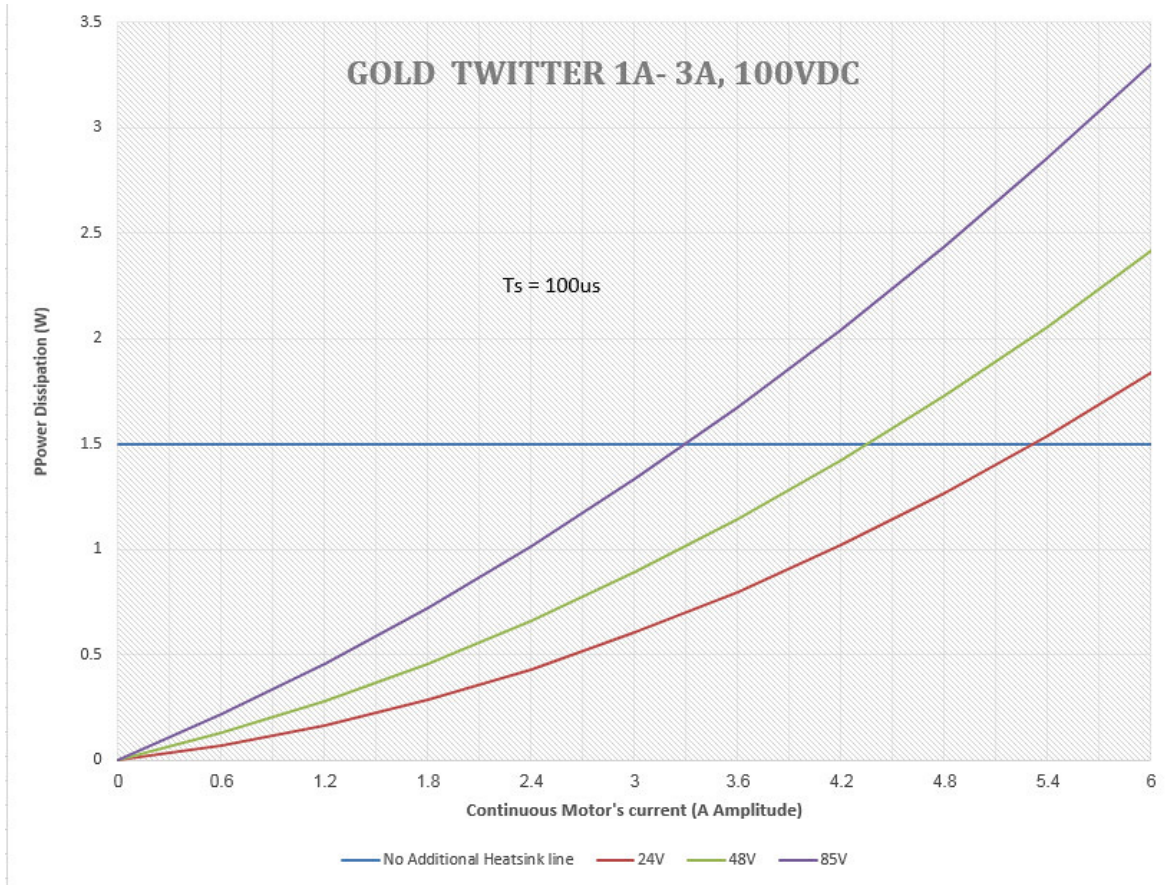

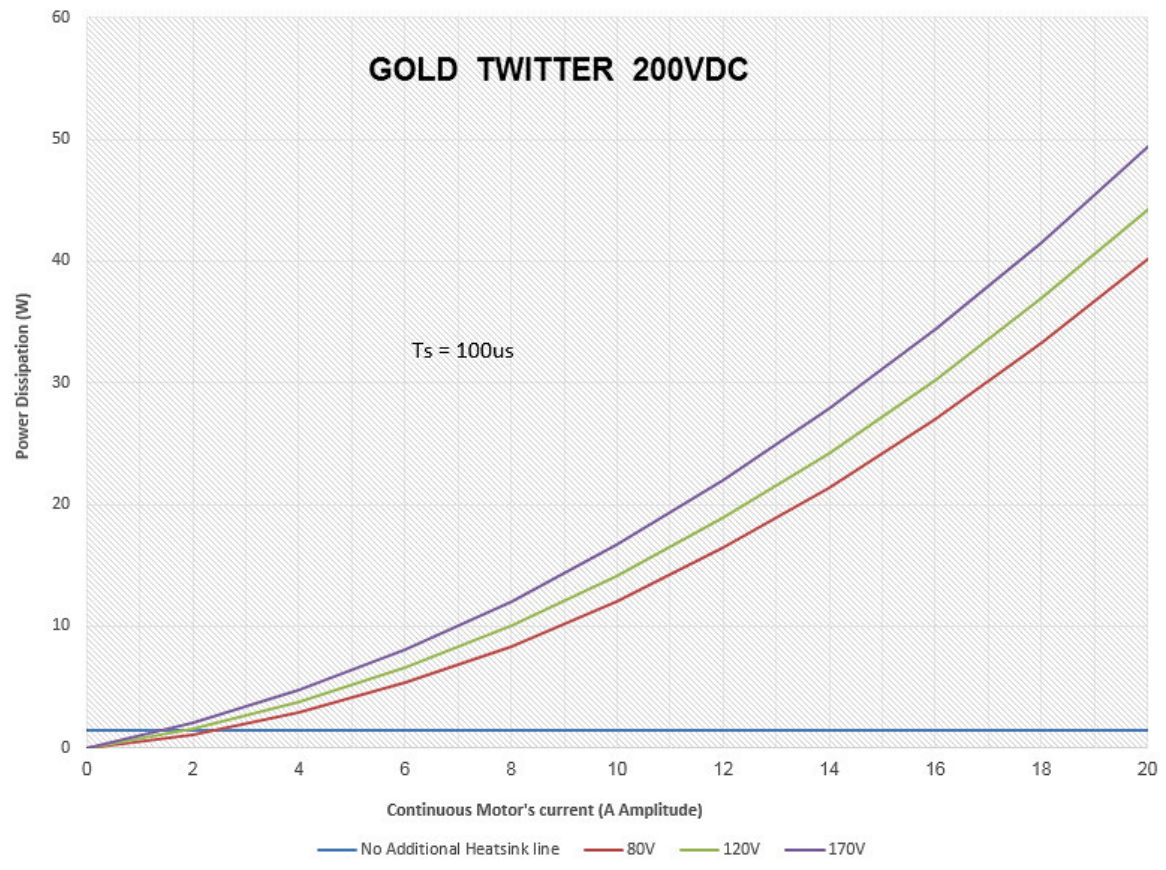
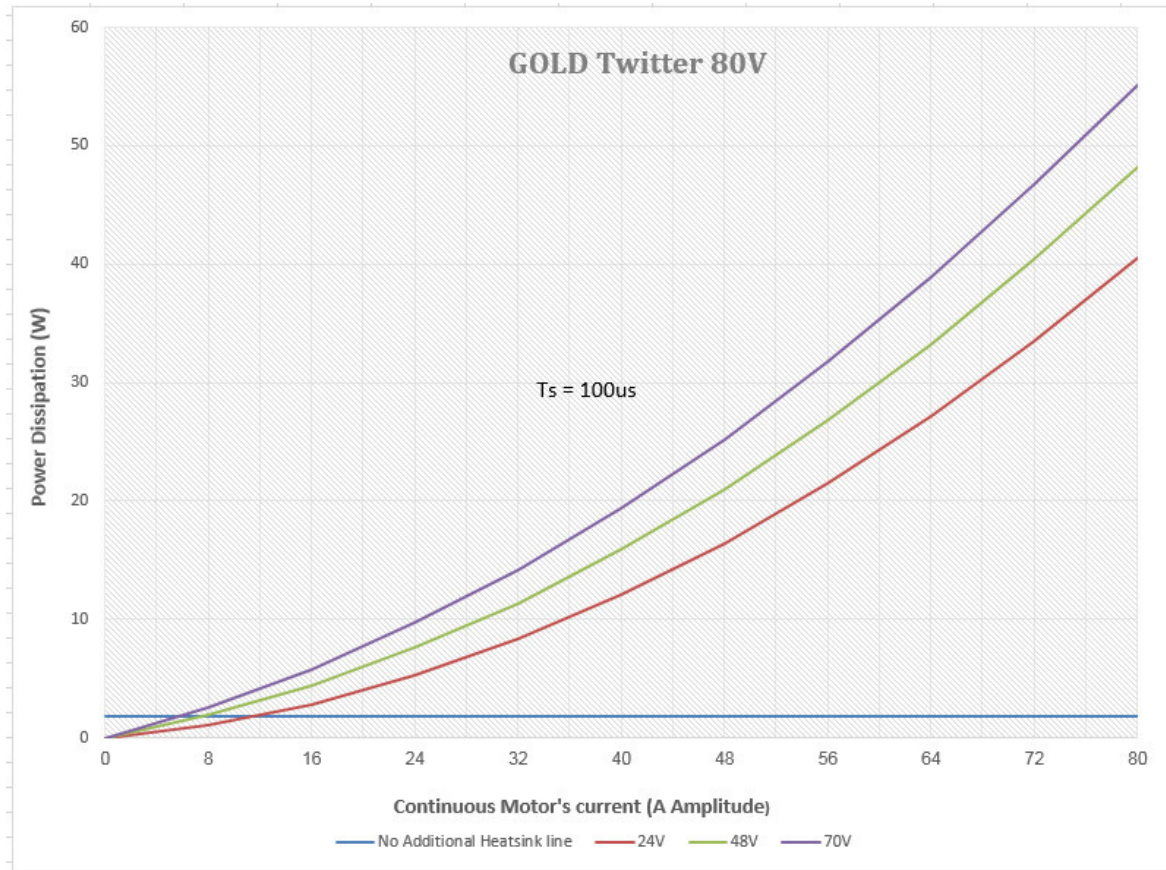



11.2.2. How to Use the Chart

The charts above are based upon the theoretical worst-case scenario. The actual test results display a 20% -30% lower power dissipation.

The above charts indicate the net power conversion losses and exclude the control losses.

To determine if your application heat dissipation requires a heat sink:

1. Determine the power dissipation according to the "continuous current" and the DC bus voltage curve.
If the DC bus is not one of the three curves above, estimate the dissipation by interpolation. The estimation error is not critical.
2. The chart is calculated for continuous current operation, if the actual operation is pulsed current, add 25% to 30% to the power dissipation of the average (RMS) current.
3. When the Heat-Sink temperature reaches $\approx 85^{\circ}\text{C}$, the Gold Twitter will shut down. Design the system for continuous operation so that the maximum Heat Sink temperature should be no higher than between 80°C to 82°C .
4. For model **G-TWIXXX/YYYYZ(Blank) or S**
If the average heat dissipation is less than $\approx 1.5\text{W}$ (Average operating power of 100W to 200W) there will be no requirement for an external heat sink.
If the average Heat dissipation is higher than 1.5W then an additional heat dissipation means is required, usually by connecting to an external heat-sink.
For model **G-TWIXXX/YYYYZH**
If the average heat dissipation is less than $\approx 4\text{W}$ to 5W (Average operating power of 300W to 600W) there will be no requirement for an additional external heat sink.
If the average Heat dissipation is higher than 4W then an additional heat dissipation means is required, usually by connecting to an additional external heat-sink.
5. When an external Heat-Sink is required, calculate the thermal resistance of the heat sink according to:

$$\theta_{\text{C/W}} = \frac{80^{\circ}\text{C} - T_{\text{Ambient}}}{\text{Heat Dissipation}}$$



Chapter 12: Dimensions

This chapter provides detailed technical dimensions regarding the Gold Twitter.

12.1. EtherCAT without Heatsink

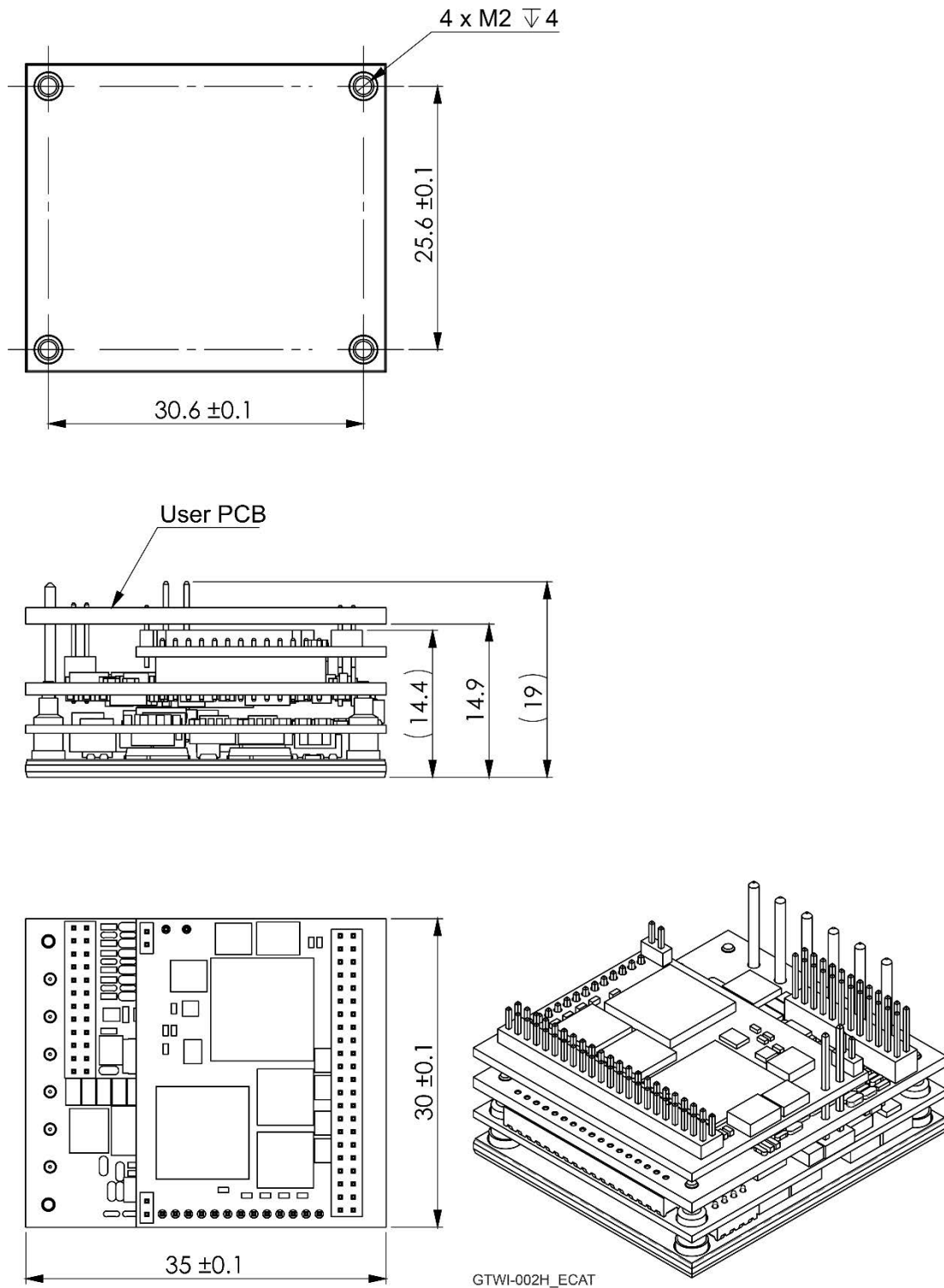

Figure 46: G-Twitter –EtherCAT version



12.2. EtherCAT with Heatsink

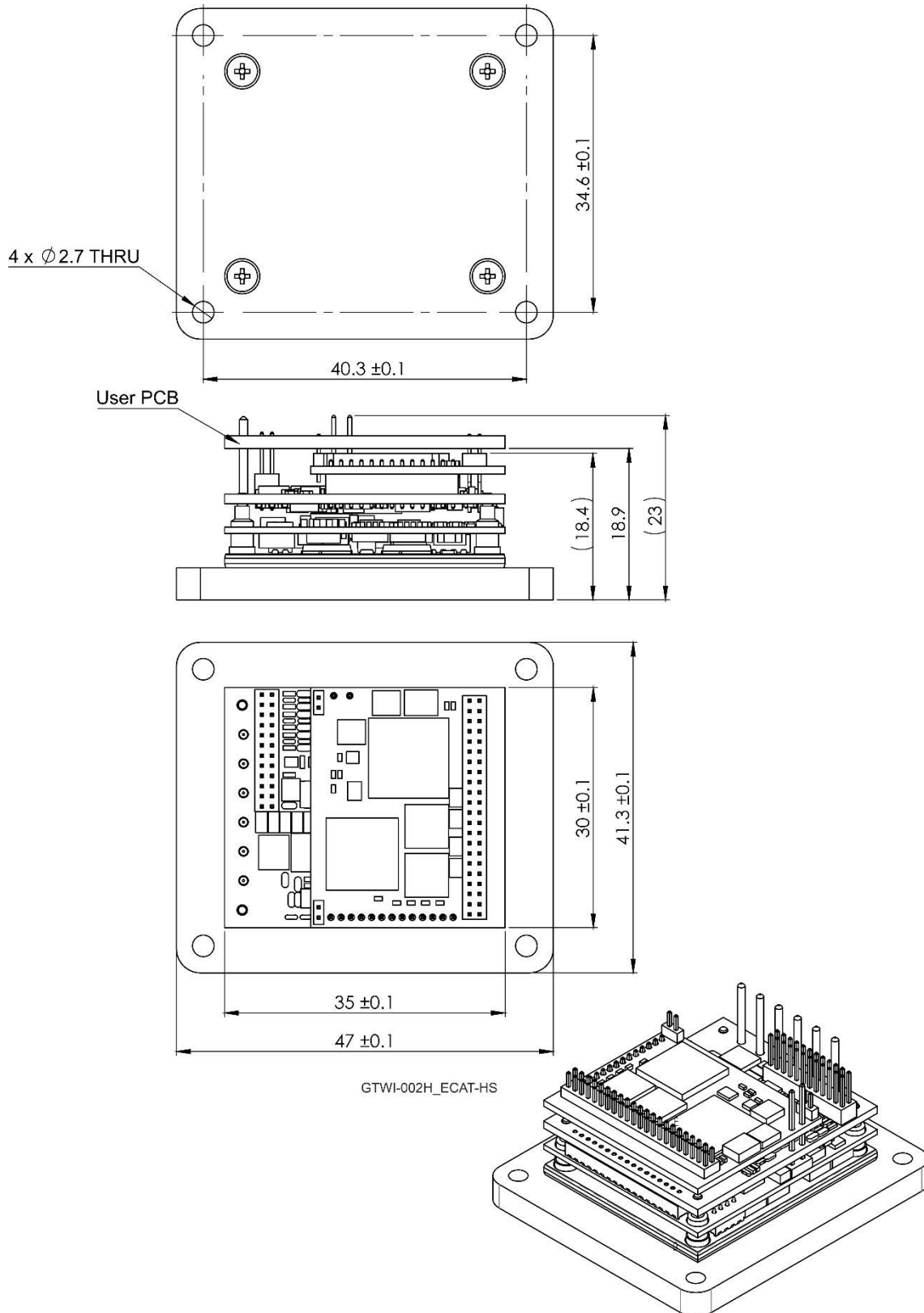
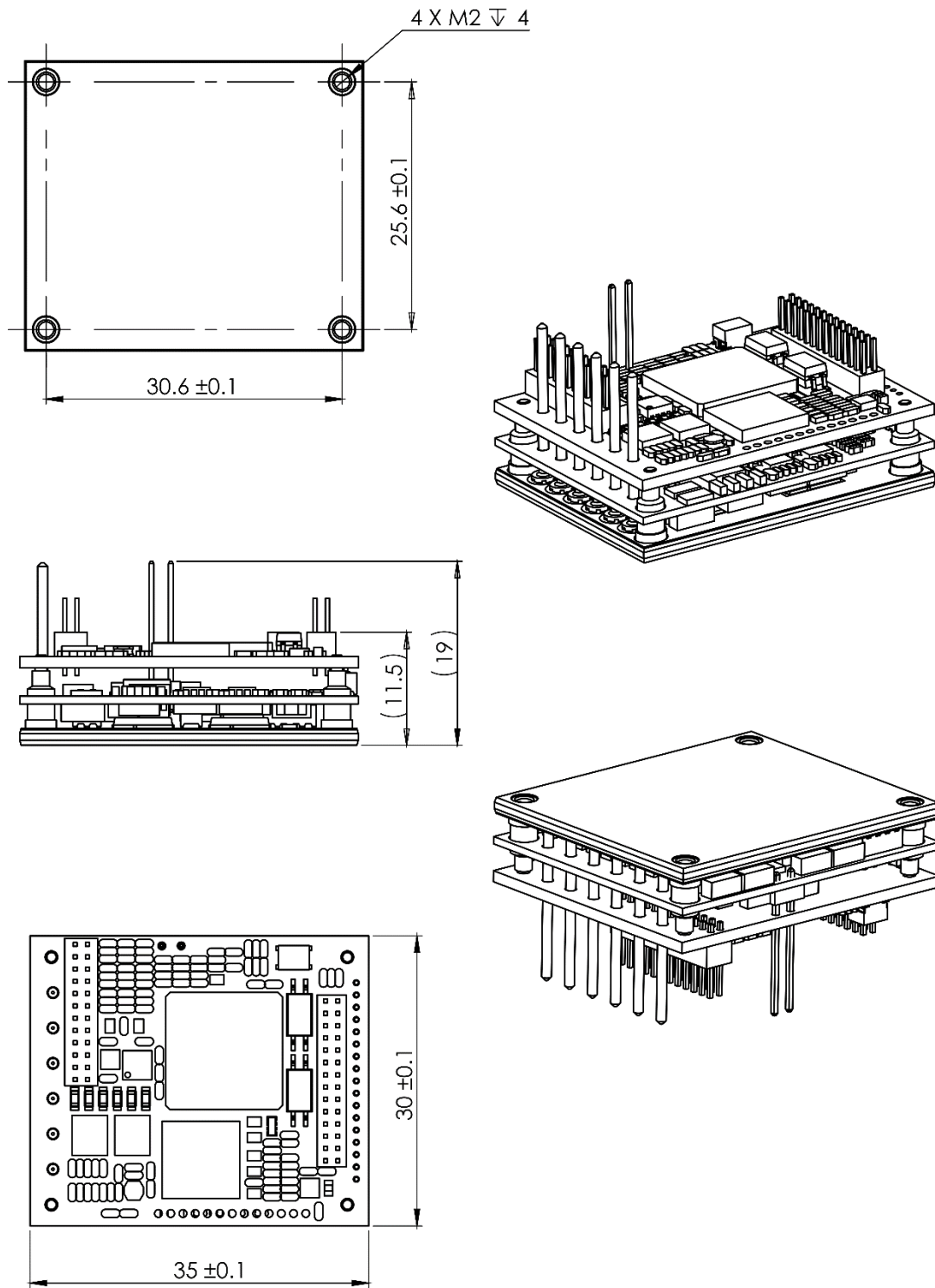

Figure 47: G-Twitter –EtherCAT version



12.3. CAN without Heatsink



G-TWI CAN without HS

Figure 48: G-Twitter –CAN version



12.4. CAN with Heatsink

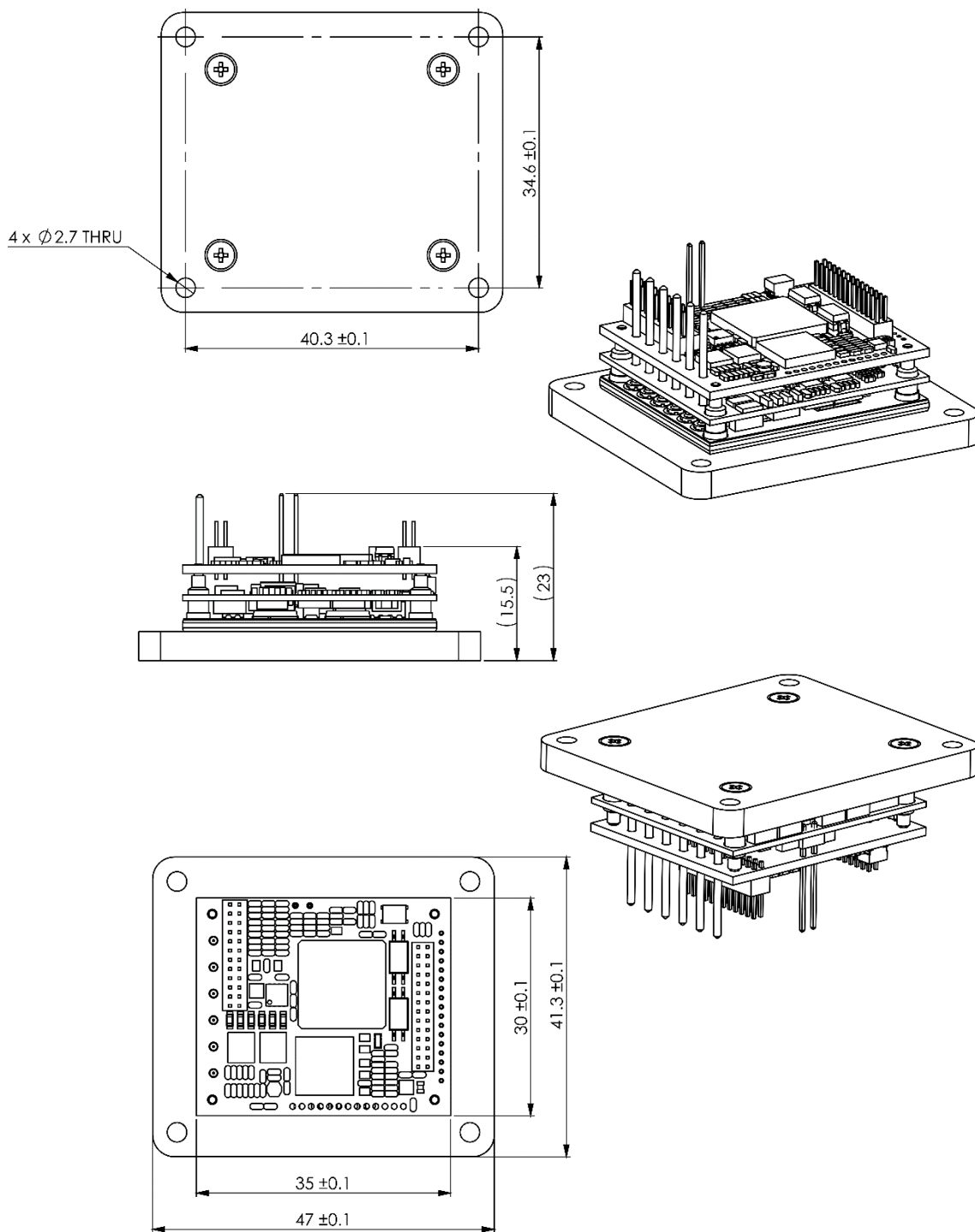

G-TWI CAN + HS

Figure 49: G-Twitter –CAN version



Chapter 13: Accessories

The model **G-TWIXXX/YYZZH** is integrated with the Flat Heatsink P/N G-TWIHSFLAT01.

The following describes the accessory kits available for the Gold Twitter.

| Part Number | Description |
|---------------|--------------------|
| G-TWIHSFLAT01 | Flat Heat-Sink Kit |
| G-TWIHSFINS01 | FINs Heat-Sink Kit |

Optionally, the Gold Twitter has two standard heat-sink configurations which are obtainable separately as kit accessories from Elmo:

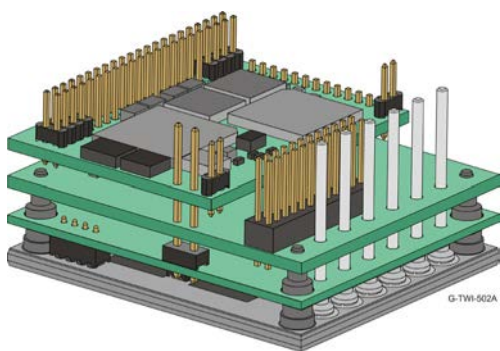

Default Heat Sink

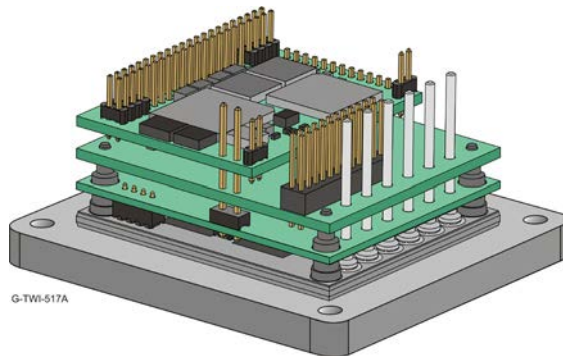

Flat Heat Sink (P/N G-TWIHSFLAT01)

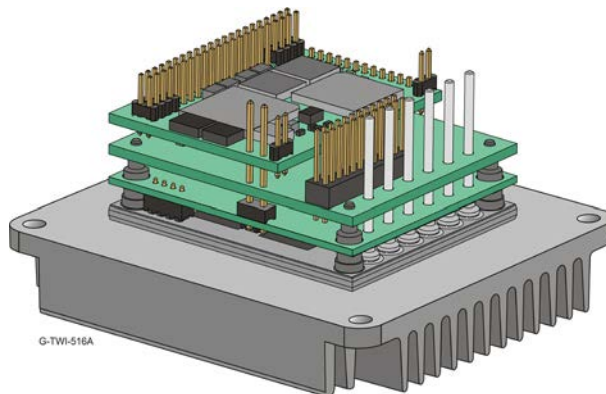

Fins Heat Sink (P/N G-TWIHSFINS01)



13.1. Accessories Heat Sink Dimensions

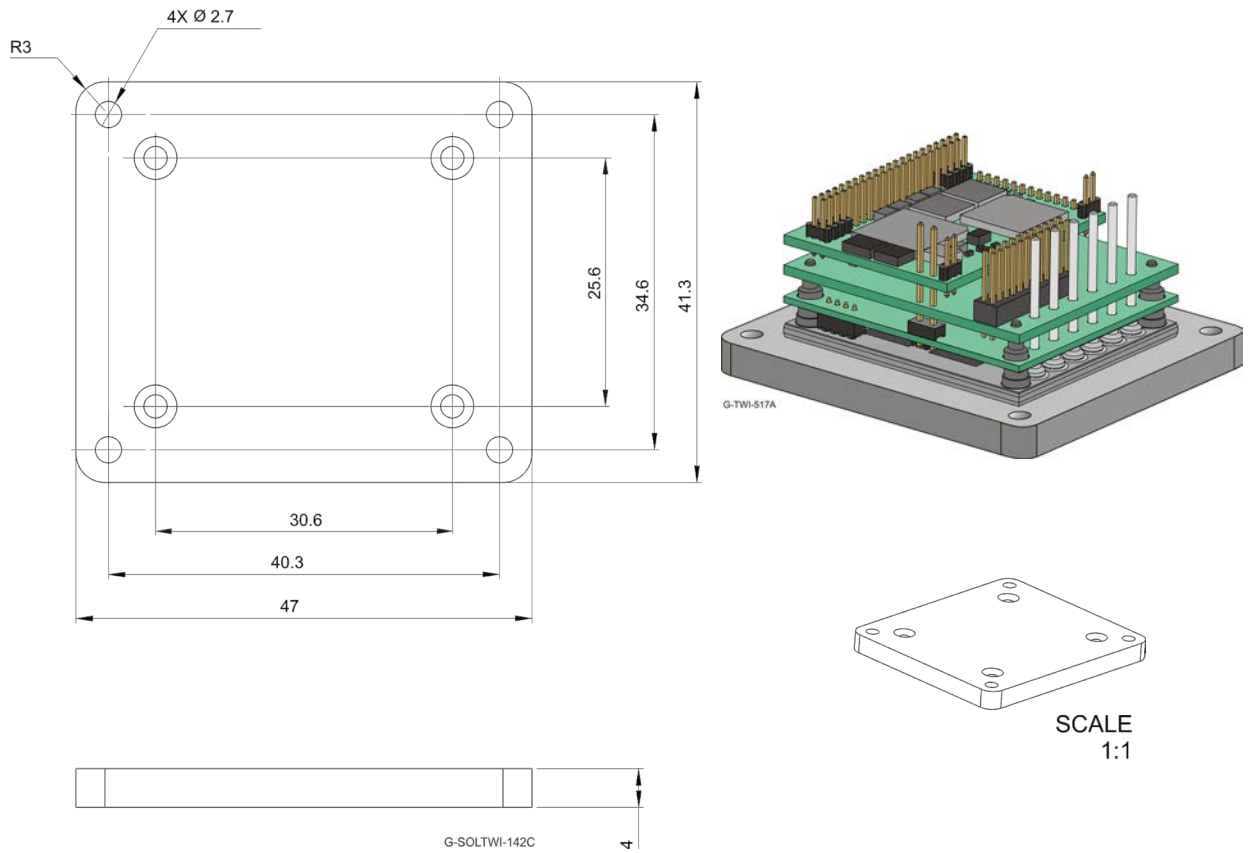

Figure 50: G-Twitter – Flat Heat Sink (P/N G-TWIHSFLAT01) Dimensions

Inspiring Motion

Since 1988

For a list of Elmo's branches, and your local area office, refer to the Elmo site www.elmomc.com

