

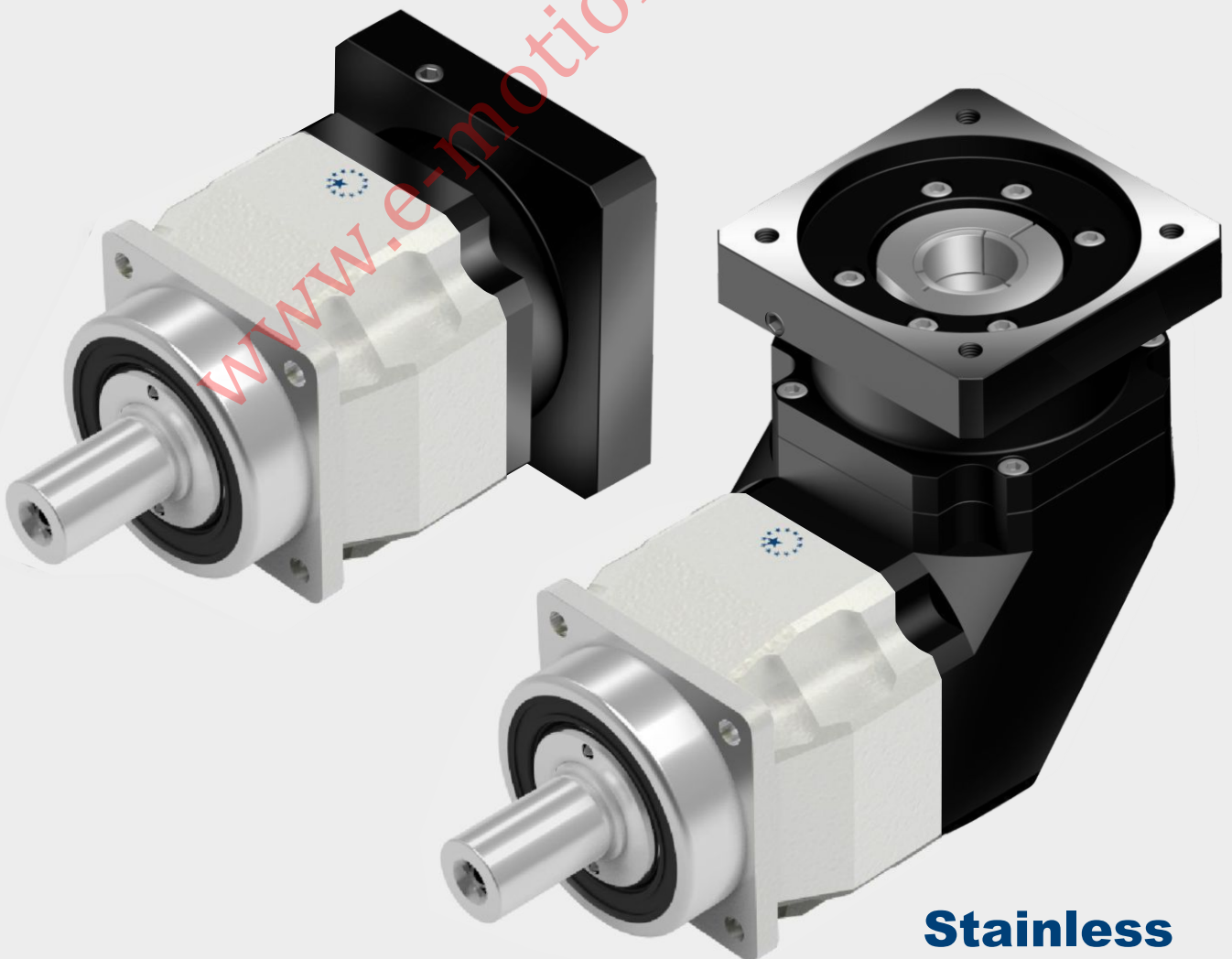

**APEX DYNAMICS, INC.**

**HIGH PRECISION  
HIGH SPEED  
PLANETARY GEARBOX**

**AF / AFR Series**



**Stainless**



**Apex Dynamics, Inc.** is the world's most productive manufacturer of servomotor drive planetary gearboxes for precision automation machinery. From our 800,000+ square foot ISO 9001:2008 manufacturing facility, based in Taichung, Taiwan, we manufacture to stock using the newest precision machine tools and quality test and inspection equipment. Complete focus on quality and precision allows us to produce our high quality gearheads at precision levels down to less than 1 arc minute (1/60 th of a degree), with consistency and high reliability.

Based on more than twenty years of accumulated manufacturing and marketing experience, plus the highest level of technical production capabilities, Apex Dynamics, Inc. designs and builds technically advanced, high speed, low backlash servo application planetary gearboxes. Our Break through patented technology (over 6 patents), provides the customer with the optimum high precision helical reducer at a reasonable price. We are continuously improving processes, finding proper and effective methods to provide customers new solutions for difficult applications, and developing new products.

The primary focus in daily operation is quality. We pride ourselves on our dedication to quality; our duty - is customer satisfaction.



# AF Series

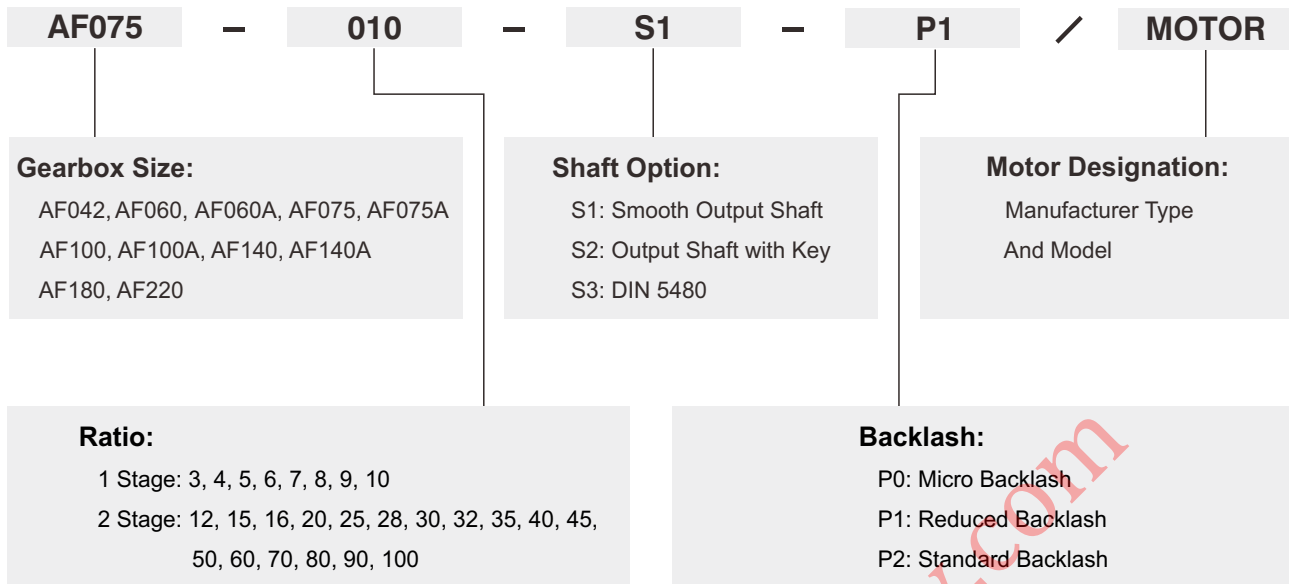

**Ordering Example: AF075-010-S1-P1 / SIEMENS 1FT6 041-4AF71**

# AFR Series

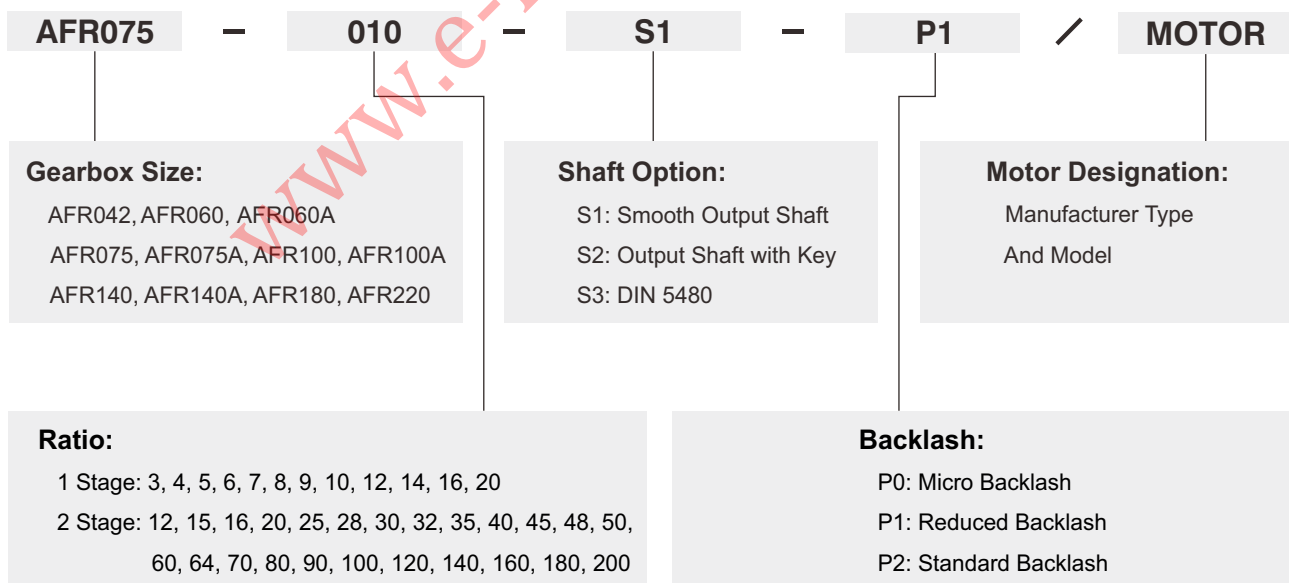

**Ordering Example: AFR075-010-S1-P1 / SIEMENS 1FT6 041-4AF71**



©2019 by APEX DYNAMICS, INC.  
APEX DYNAMICS, INC. reserves modification and copyrights of all technical specifications, illustrations and drawings in this catalog in allowance for continuous products development and advancement.  
For the newest data and information, please visit <http://www.e-motionsupply.com>

# Specifications / AF Series

## Gearbox Performance

Model No.		Stage	Ratio <sup>(1)</sup>	AF042	AF060	AF060A	AF075	AF075A	AF100	AF100A	AF140	AF140A	AF180	AF220
Nominal Output Torque $T_{2N}$	Nm	1	3	20	55	-	130	-	208	-	342	-	588	1,140
			4	19	50	-	140	-	290	-	542	-	1,050	1,700
			5	22	60	-	160	-	330	-	650	-	1,200	2,000
			6	20	55	-	150	-	310	-	600	-	1,100	1,900
			7	19	50	-	140	-	300	-	550	-	1,100	1,800
			8	17	45	-	120	-	260	-	500	-	1,000	1,600
			9	14	40	-	100	-	230	-	450	-	900	1,500
			10	14	40	-	100	-	230	-	450	-	900	1,500
			12	19	50	50	140	140	290	290	542	542	1,050	1,700
			15	20	55	55	130	130	208	208	342	342	588	1,140
		16	19	50	50	140	140	290	290	542	542	1,050	1,700	
		20	19	50	50	140	140	290	290	542	542	1,050	1,700	
		25	22	60	60	160	160	330	330	650	650	1,200	2,000	
		28	19	50	50	140	140	300	300	550	550	1,100	1,800	
		30	20	55	55	150	150	310	310	600	600	1,100	1,900	
		32	17	45	45	120	120	260	260	500	500	1,000	1,600	
		35	19	50	50	140	140	300	300	550	550	1,100	1,800	
		40	17	45	45	120	120	260	260	500	500	1,000	1,600	
		45	14	40	40	100	100	230	230	450	450	900	1,500	
		50	22	60	60	160	160	330	330	650	650	1,200	2,000	
60	20	55	55	150	150	310	310	600	600	1,100	1,900			
70	19	50	50	140	140	300	300	550	550	1,100	1,800			
80	17	45	45	120	120	260	260	500	500	1,000	1,600			
90	14	40	40	100	100	230	230	450	450	900	1,500			
100	14	40	40	100	100	230	230	450	450	900	1,500			
Emergency Stop Torque $T_{2NOT}$ <sup>(2)</sup>	Nm	1,2	3~100	3 times of Nominal Output Torque										
Nominal Input Speed $n_{iN}$	rpm	1,2	3~100	5,000	5,000	5,000	4,000	4,000	4,000	4,000	3,000	3,000	3,000	2,000
Max. Input Speed $n_{iB}$	rpm	1,2	3~100	10,000	10,000	10,000	8,000	8,000	8,000	8,000	6,000	6,000	6,000	4,000
Micro Backlash $P_0$	arcmin	1	3~10	-	-	-	≤1	-	≤1	-	≤1	-	≤1	≤1
		2	12~100	-	-	-	-	≤3	≤3	≤3	≤3	≤3	≤3	≤3
Reduced Backlash $P_1$	arcmin	1	3~10	≤3	≤3	-	≤3	-	≤3	-	≤3	-	≤3	≤3
		2	12~100	≤5	≤5	≤5	≤5	≤5	≤5	≤5	≤5	≤5	≤5	≤5
Standard Backlash $P_2$	arcmin	1	3~10	≤5	≤5	-	≤5	-	≤5	-	≤5	-	≤5	≤5
		2	12~100	≤7	≤7	≤7	≤7	≤7	≤7	≤7	≤7	≤7	≤7	≤7
Torsional Rigidity	Nm/arcmin	1,2	3~100	3	7	7	14	14	25	25	50	50	145	225
Max. Radial Load $F_{2rB}$ <sup>(3)</sup>	N	1,2	3~100	610	1,400	1,400	4,100	4,100	9,200	9,200	14,000	14,000	18,000	33,000
Max. Axial Load $F_{2aB}$ <sup>(3)</sup>	N	1,2	3~100	320	1,100	1,100	3,700	3,700	5,820	5,820	11,400	11,400	19,500	16,300
Max. Tilting Moment $M_{2K}$	Nm	1,2	3~100	20	85	85	380	380	970	970	1,840	1,840	2,740	5,030
Efficiency $\eta$	%	1	3~10	≥97%										
		2	12~100	≥94%										
Weight	kg	1	3~10	0.6	1.3	-	3.7	-	6.9	-	12.6	-	25.5	45
		2	12~100	0.8	1.5	2	4.1	5.5	8.1	10.6	16.6	20.2	31.5	57
Operating Temp	°C	1,2	3~100	-10°C~90°C										
Lubrication		1,2	3~100	Synthetic lubrication oils										
Degree of Gearbox Protection		1,2	3~100	IP65										
Mounting Position		1,2	3~100	all directions										
Noise <sup>(4)</sup>	dB(A)	1,2	3~100	≤56	≤58	≤60	≤60	≤63	≤63	≤65	≤65	≤67	≤67	≤70

(1) Ratio ( $i=N_{in}/N_{out}$ )

(2) Max. acceleration torque  $T_{2B} = 60\%$  of  $T_{2NOT}$

(3) Applied to the output shaft center at 100 rpm

(4) The dB values are measured by gearbox with ratio 10 (1-stage) or ratio 100 (2-stage), no loading at 3,000 RPM or at the respective Nominal Input Speed by bigger model size.  
By lower ratio and/or higher RPM, the noise level could be 3 to 5 dB higher.

# Max. Tilting Moment $M_{2k}$

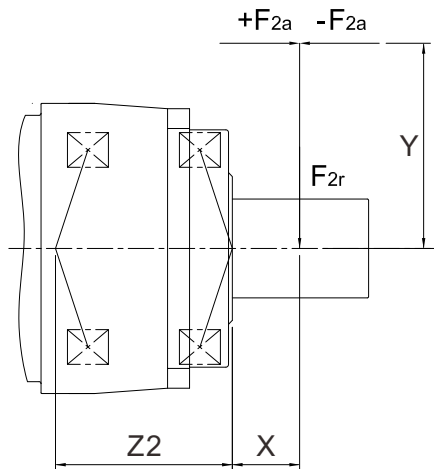

$$M_{2K} = \frac{F_{2a} * Y + F_{2r} * (X+Z2)}{1000}$$

$M_{2K}$  : [Nm]  
 $F_{2a}, F_{2r}$  : [N]  
 $X, Y, Z2$  : [mm]

AF / AFR	042	060	075	100	140	180	220
Z2 [mm]	31	66.5	88.7	96	114.2	138.7	127.1

Note : Applied to the output shaft center at 100 rpm.

## Gearbox Inertia

Model No.	Stage	Ratio	AF042	AF060	AF060A	AF075	AF075A	AF100	AF100A	AF140	AF140A	AF180	AF220	
Mass Moments of Inertia $J_1$	1	3	0.03	0.16	-	0.61	-	3.25	-	9.21	-	28.98	69.61	
		4	0.03	0.14	-	0.48	-	2.74	-	7.54	-	23.67	54.37	
		5	0.03	0.13	-	0.47	-	2.71	-	7.42	-	23.29	53.27	
		6	0.03	0.13	-	0.45	-	2.65	-	7.25	-	22.75	51.72	
		7	0.03	0.13	-	0.45	-	2.62	-	7.14	-	22.48	50.97	
		8	0.03	0.13	-	0.44	-	2.58	-	7.07	-	22.59	50.84	
		9	0.03	0.13	-	0.44	-	2.57	-	7.04	-	22.53	50.63	
		10	0.03	0.13	-	0.44	-	2.57	-	7.03	-	22.51	50.56	
		12	0.03	0.03	0.16	0.16	0.61	0.61	3.25	3.25	9.21	9.21	28.98	28.98
		15	0.03	0.03	0.13	0.13	0.47	0.47	2.71	2.71	7.42	7.42	23.29	23.29
	16	0.03	0.03	0.14	0.14	0.48	0.48	2.74	2.74	7.54	7.54	23.67	23.67	
	20	0.03	0.03	0.13	0.13	0.47	0.47	2.71	2.71	7.42	7.42	23.29	23.29	
	25	0.03	0.03	0.13	0.13	0.47	0.47	2.71	2.71	7.42	7.42	23.29	23.29	
	28	0.03	0.03	0.14	0.14	0.48	0.48	2.74	2.74	7.54	7.54	23.67	23.67	
	30	0.03	0.03	0.13	0.13	0.47	0.47	2.71	2.71	7.42	7.42	23.29	23.29	
	32	0.03	0.03	0.14	0.14	0.48	0.48	2.74	2.74	7.54	7.54	23.67	23.67	
	35	0.03	0.03	0.13	0.13	0.47	0.47	2.71	2.71	7.42	7.42	23.29	23.29	
	40	0.03	0.03	0.13	0.13	0.47	0.47	2.71	2.71	7.42	7.42	23.29	23.29	
	45	0.03	0.03	0.13	0.13	0.47	0.47	2.71	2.71	7.42	7.42	23.29	23.29	
	50	0.03	0.03	0.13	0.13	0.44	0.44	2.57	2.57	7.03	7.03	22.51	22.51	
60	0.03	0.03	0.13	0.13	0.44	0.44	2.57	2.57	7.03	7.03	22.51	22.51		
70	0.03	0.03	0.13	0.13	0.44	0.44	2.57	2.57	7.03	7.03	22.51	22.51		
80	0.03	0.03	0.13	0.13	0.44	0.44	2.57	2.57	7.03	7.03	22.51	22.51		
90	0.03	0.03	0.13	0.13	0.44	0.44	2.57	2.57	7.03	7.03	22.51	22.51		
100	0.03	0.03	0.13	0.13	0.44	0.44	2.57	2.57	7.03	7.03	22.51	22.51		

# Dimensions (1-stage, Ratio $i=3\sim 10$ ) / AF Series

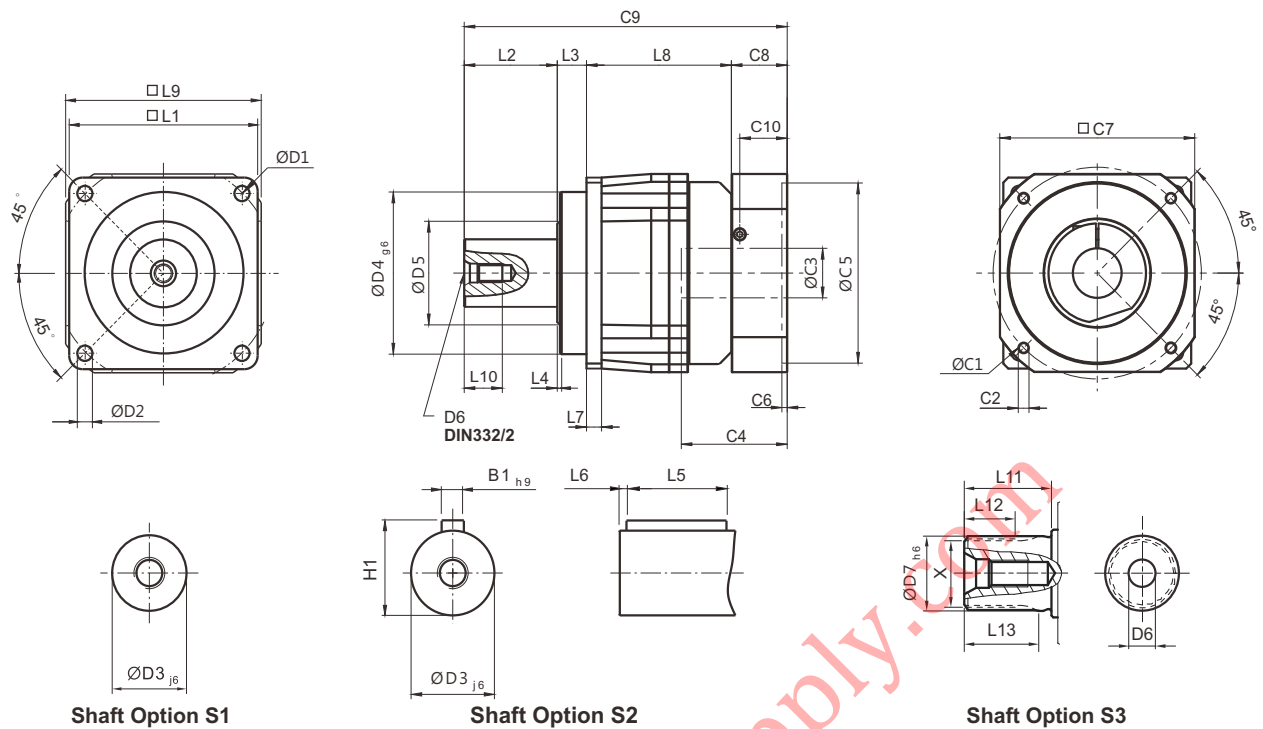

[unit: mm]

Dimension	AF042	AF060	AF075	AF100	AF140	AF180	AF220
D1	50	68	85	120	165	215	250
D2	3.4	5.5	6.8	9	11	13	17
D3 <sub>j6</sub>	13	16	22	32	40	55	75
D4 <sub>g6</sub>	35	60	70	90	130	160	180
D5	22	45	60	80	75	95	115
D6	M4 x 0.7P	M5 x 0.8P	M8 x 1.25P	M12 x 1.75P	M16 x 2P	M20 x 2.5P	M20 x 2.5P
D7 <sub>h6</sub>	-	16	22	32	40	55	75
L1	42	62	76	105	142	180	220
L2	19.5	28.5	36	58	82	82	105
L3	6.5	20	20	30	30	30	33
L4	1	1.5	2	2	3	3	3
L5	16	25	32	40	63	70	90
L6	2	2	3	5	5	6	7
L7	4	6	7	10	12	15	20
L8	31	54.5	86.5	89.5	110	150	163.5
L9	42	60	90	115	142	180	220
L10	10	12.5	19	28	36	42	42
L11	-	26	26	26	40	41.5	52
L12	-	15	15	15	20	21.5	28
L13	-	21	22.5	23	33.5	33.5	45
C1 <sup>1</sup>	46	70	100	130	165	215	235
C2 <sup>1</sup>	M4 x 0.7P	M5 x 0.8P	M6 x 1P	M8 x 1.25P	M10 x 1.5P	M12 x 1.75P	M12 x 1.75P
C3 <sup>1</sup>	≤11 / ≤12 <sup>2</sup>	≤14 / ≤16 <sup>2</sup>	≤19 / ≤24 <sup>2</sup>	≤32	≤38	≤48	≤55
C4 <sup>1</sup>	25	34	40	50	60	85	116
C5 <sup>1</sup>	30	50	80	110	130	180	200
C6 <sup>1</sup>	3.5	8	4	5	6	6	6
C7 <sup>1</sup>	42	60	90	115	142	190	220
C8 <sup>1</sup>	29.5	19	17	19.5	22.5	29	63
C9 <sup>1</sup>	86.5	122	159.5	197	244.5	291	364.5
C10 <sup>1</sup>	8.75	13.5	10.75	13	15	20.75	53
B1 <sub>h9</sub>	5	5	6	10	12	16	20
H1	15	18	24.5	35	43	59	79.5
X DIN5480	-	W16x0.8x 30x18x6m	W22x1.25x 30x16x6m	W32x1.25x 30x24x6m	W40x2x 30x18x6m	W55x2x 30x26x6m	W70x2x 30x34x6m

1. C1~C10 are motor specific dimensions (metric std shown). Refer to [www.apexdyna.com](http://www.apexdyna.com) and Design Tool to view your specific motor mounting system.  
 2. AF042M1 ratio 5, 10 offers C3 ≤ 12 option; AF060M1 ratio 5, 10 offers C3 ≤ 16 option; AF075M1 offers C3 ≤ 24 option.

# Dimensions (2-stage, Ratio i = 12~100) / AF Series

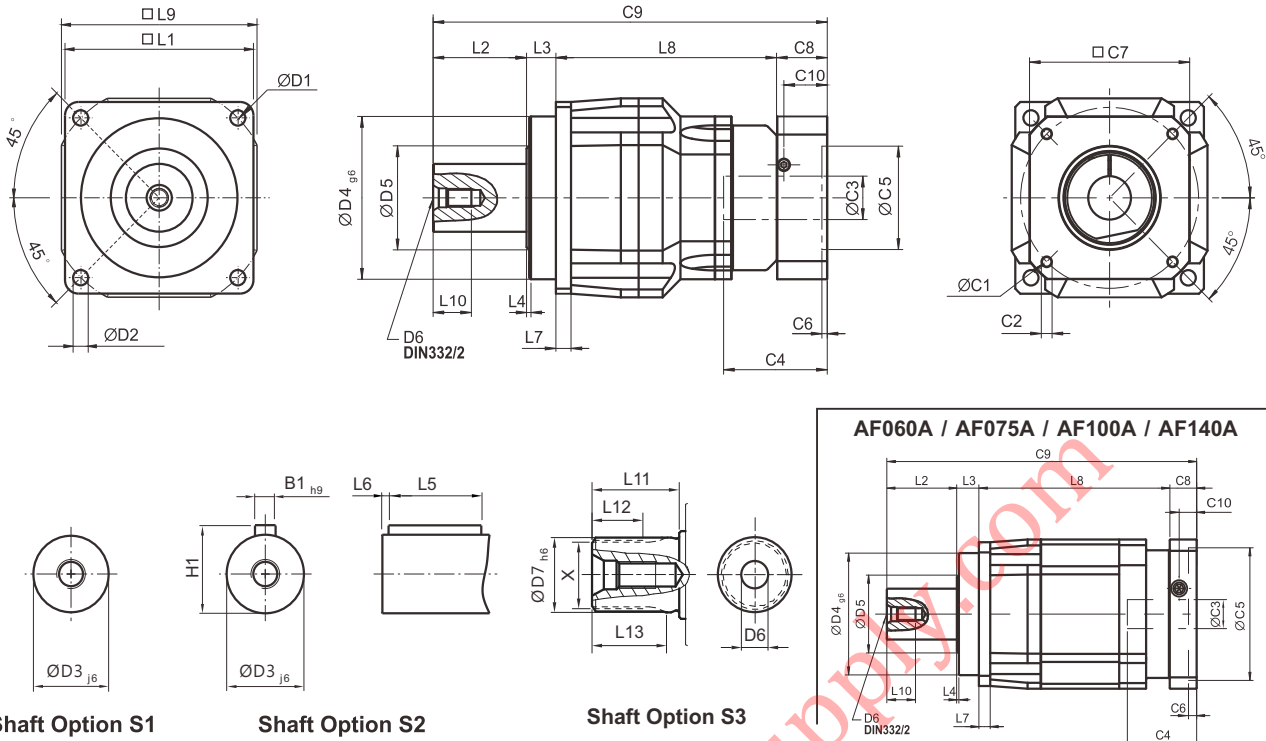

Shaft Option S1

Shaft Option S2

Shaft Option S3

[unit: mm]

Dimension	AF042	AF060	AF060A	AF075	AF075A	AF100	AF100A	AF140	AF140A	AF180	AF220
D1	50	68		85		120		165		215	250
D2	3.4	5.5		6.8		9		11		13	17
D3 <sub>j6</sub>	13	16		22		32		40		55	75
D4 <sub>g6</sub>	35	60		70		90		130		160	180
D5	22	45		60		80		75		95	115
D6	M4x0.7P	M5 x 0.8P		M8 x 1.25P		M12 x 1.75P		M16 x 2P		M20x2.5P	M20x2.5P
D7	56	16		22		32		40		55	75
L1	42	62		76		105		142		180	220
L2	19.5	28.5		36		58		82		82	105
L3	6.5	20		20		30		30		30	33
L4	1	1.5		2		2		3		3	3
L5	16	25		32		40		63		70	90
L6	2	2		3		5		5		6	7
L7	4	6		7		10		12		15	20
L8	58.5	65.5	91.5	119.5	134.5	131	150.5	166.5	181.5	205.5	248
L9	42	60		90		115		142		180	220
L10	10	12.5		19		28		36		42	42
L11	-	26		26		26		40		41.5	52
L12	-	15		15		15		20		21.5	28
L13	-	21		22.5		23		33.5		33.5	45
C1 <sup>3</sup>	46	46	70	70	100	100	130	130	165	165	215
C2 <sup>3</sup>	M4x0.7P	M4x0.7P	M5 x 0.8P	M5 x 0.8P	M6 x 1P	M6 x 1P	M8x1.25P	M8x1.25P	M10x1.5P	M10x1.5P	M12x1.75P
C3 <sup>3</sup>	≤11 / ≤12 <sup>4</sup>	≤11 / ≤12 <sup>4</sup>	≤14 / ≤16 <sup>4</sup>	≤14 / ≤15.875 / ≤16 <sup>4</sup>	≤19 / ≤24 <sup>4</sup>	≤19 / ≤24 <sup>4</sup>	≤32	≤32	≤38	≤38	≤48
C4 <sup>3</sup>	25	25	34	34	40	40	50	50	60	60	85
C5 <sup>3</sup>	30	30	50	50	80	80	110	110	130	130	180
C6 <sup>3</sup>	3.5	3.5	8	8	4	4	5	5	6	6	6
C7 <sup>3</sup>	42	42	60	60	90	90	115	115	142	142	190
C8 <sup>3</sup>	29.5	29.5	19	19	17	17	19.5	19.5	22.5	22.5	29
C9 <sup>3</sup>	114	143.5	159	194.5	207.5	207.5	258	298	316	340	415
C10 <sup>3</sup>	8.75	8.75	13.5	13.5	10.75	10.75	13	13	15	15	20.75
B1 <sub>hg</sub>	5	5		6		10		12		16	20
H1	15	18		24.5		35		43		59	79.5
X DIN5480	-	W16x0.8x 30x18x6m		W22x1.25x 30x16x6m		W32x1.25x 30x24x6m		W40x2x 30x18x6m		W55x2x 30x26x6m	W70x2x 30x34x6m

3. C1-C10 are motor specific dimensions (metric std shown). Refer to www.apexdyna.com and Design Tool to view your specific motor mounting system.

4. AF042M1 offers C3 ≤ 12 option; AF060/A M1 offers C3 ≤ 12/16 option; AF075/A M1 offers C3 ≤ 16/24 option; AF075 M2 offers C3 ≤ 15.875 option. AF100M1 offers C3 ≤ 24 option.

# Specifications / AFR Series

## Gearbox Performance

Model No.		Stage	Ratio <sup>(1)</sup>	AFR042	AFR060	AFR060A	AFR075	AFR075A	AFR100	AFR100A	AFR140	AFR140A	AFR180	AFR220	
Nominal Output Torque $T_{2N}$	Nm	1	3	9	36	-	90	-	195	-	342	-	588	1,140	
			4	12	48	-	120	-	260	-	520	-	1,040	1,680	
			5	15	60	-	150	-	325	-	650	-	1,200	2,000	
			6	18	55	-	150	-	310	-	600	-	1,100	1,900	
			7	19	50	-	140	-	300	-	550	-	1,100	1,800	
			8	17	45	-	120	-	260	-	500	-	1,000	1,600	
			9	14	40	-	100	-	230	-	450	-	900	1,500	
			10	14	60	-	150	-	325	-	650	-	1,200	2,000	
			12	-	55	-	150	-	310	-	600	-	1,100	1,900	
			14	-	42	-	140	-	300	-	550	-	1,100	1,800	
			16	-	45	-	120	-	260	-	500	-	1,000	1,600	
			20	-	40	-	100	-	230	-	450	-	900	1,500	
		2	12	12	-	-	-	-	-	-	-	-	-	-	-
			15	14	-	-	-	-	-	-	-	-	-	-	-
			16	15	-	-	-	-	-	-	-	-	-	-	-
			20	14	-	-	-	-	-	-	-	-	-	-	-
			25	15	60	60	150	150	325	325	650	650	1,200	2,000	
			28	19	50	50	140	140	300	300	550	550	1,100	1,800	
			30	20	55	55	150	150	310	310	600	600	1,100	1,900	
			32	17	45	45	120	120	260	260	500	500	1,000	1,600	
			35	19	50	50	140	140	300	300	550	550	1,100	1,800	
			40	17	45	45	120	120	260	260	500	500	1,000	1,600	
			45	14	40	40	100	100	230	230	450	450	900	1,500	
			48	-	-	55	150	150	310	310	600	600	1,100	1,900	
			50	14	60	60	150	150	325	325	650	650	1,200	2,000	
			60	20	55	55	150	150	310	310	600	600	1,100	1,900	
			64	-	-	45	120	120	260	260	500	500	1,000	1,600	
			70	19	50	50	140	140	300	300	550	550	1,100	1,800	
			80	17	45	45	120	120	260	260	500	500	1,000	1,600	
			90	14	40	40	100	100	230	230	450	450	900	1,500	
			100	14	40	60	150	150	325	325	650	650	1,200	2,000	
			120	-	-	55	150	150	310	310	600	600	1,100	1,900	
		140	-	-	50	140	140	300	300	550	550	1,100	1,800		
		160	-	-	45	120	120	260	260	500	500	1,000	1,600		
		180	-	-	40	100	100	230	230	450	450	900	1,500		
		200	-	-	40	100	100	230	230	450	450	900	1,500		
Emergency Stop Torque $T_{2NOT}^{(2)}$	Nm	1,2	3~200	3 times of Nominal Output Torque											
Nominal Input Speed $n_{1N}$	rpm	1,2	3~200	5,000	5,000	5,000	4,000	4,000	4,000	4,000	3,000	3,000	3,000	2,000	
Max. Input Speed $n_{1B}$	rpm	1,2	3~200	10,000	10,000	10,000	8,000	8,000	8,000	8,000	6,000	6,000	6,000	4,000	
Micro Backlash P0	arcmin	1	3~20	-	-	-	≤2	-	≤2	-	≤2	-	≤2	≤2	
		2	12~200	-	-	-	≤4	≤4	≤4	≤4	≤4	≤4	≤4	≤4	
Reduced Backlash P1	arcmin	1	3~20	≤4	≤4	-	≤4	-	≤4	-	≤4	-	≤4	≤4	
		2	12~200	≤7	≤7	≤7	≤7	≤7	≤7	≤7	≤7	≤7	≤7	≤7	
Standard Backlash P2	arcmin	1	3~20	≤6	≤6	-	≤6	-	≤6	-	≤6	-	≤6	≤6	
		2	12~200	≤9	≤9	≤9	≤9	≤9	≤9	≤9	≤9	≤9	≤9	≤9	
Torsional Rigidity	Nm/arcmin	1,2	3~200	3	7	7	14	14	25	25	50	50	145	225	
Max. Radial Load $F_{2RB}^{(3)}$	N	1,2	3~200	610	1,400	1,400	4,100	4,100	9,200	9,200	14,000	14,000	18,000	33,000	
Max. Axial Load $F_{2AB}^{(3)}$	N	1,2	3~200	320	1,100	1,100	3,700	3,700	5,800	5,800	11,400	11,400	19,500	16,300	
Max. Tilting Moment $M_{2K}$	Nm		3~200	20	85	85	380	380	970	970	1,840	1,840	2,740	5,030	
Efficiency $\eta$	%	1	3~20	≥95%											
		2	12~200	≥92%											
Weight	kg	1	3~20	0.9	2.1	-	6.4	-	11.3	-	22.5	-	44	77	
		2	12~200	1.2	1.9	2.8	4.8	8	10.6	15.1	21	29.2	41	75	
Operating Temp	°C	1,2	3~200	-10°C~+90°C											
Lubrication		1,2	3~200	Synthetic lubrication oils											
Degree of Gearbox Protection		1,2	3~200	IP65											
Mounting Position		1,2	3~200	all directions											
Noise <sup>(4)</sup>	dB(A)	1,2	3~200	≤61	≤63	≤65	≤65	≤68	≤68	≤70	≤70	≤72	≤72	≤74	

(1) Ratio ( $i = N_{in} / N_{out}$ )

(2) Max. acceleration torque  $T_{2B} = 60\%$  of  $T_{2NOT}$

(3) Applied to the output shaft center at 100 rpm

(4) The dB values are measured by gearbox with ratio 10 (1-stage) or ratio 100 (2-stage), no loading at 3,000 RPM or at the respective Nominal Input Speed by bigger model size.

By lower ratio and/or higher RPM, the noise level could be 3 to 5 dB higher.



## Gearbox Inertia

Model No.	Stage	Ratio	AFR042	AFR060	AFR060 A	AFR075	AFR075A	AFR100	AFR100A	AFR140	AFR140A	AFR180	AFR220	
Mass Moments of Inertia J <sub>1</sub>	1	3~10	0.09	0.35	—	2.25	—	6.84	—	23.4	—	68.9	135.4	
		12~20	—	0.31	—	1.87	—	6.25	—	21.8	—	65.6	119.8	
	2	12~20	0.09	—	—	—	—	—	—	—	—	—	—	—
		25~90	0.09	0.09	0.35	0.35	2.25	2.25	6.84	6.84	23.4	23.4	68.9	—
		48, 64	—	—	0.31	0.31	1.87	1.87	6.25	6.25	21.8	21.8	65.6	—
		100~200	—	—	0.31	0.31	1.87	1.87	6.25	6.25	21.8	21.8	65.6	—

www.e-motionsupply.com

# Dimensions (1-stage, Ratio $i=3\sim 20$ ) / AFR Series

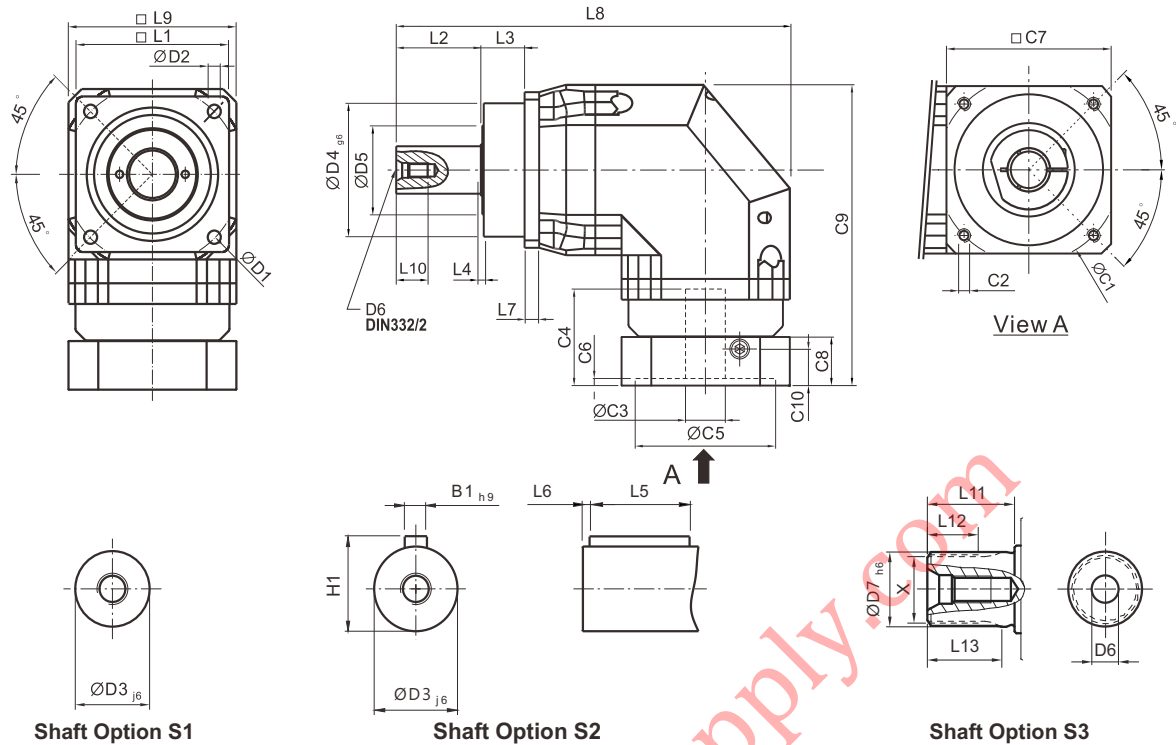

[unit: mm]

Dimension	AFR042	AFR060	AFR075	AFR100	AFR140	AFR180	AFR220
D1	50	68	85	120	165	215	250
D2	3.4	5.5	6.8	9	11	13	17
D3 <sub>j6</sub>	13	16	22	32	40	55	75
D4 <sub>g6</sub>	35	60	70	90	130	160	180
D5	22	45	60	80	75	95	115
D6	M4 x 0.7P	M5 x 0.8P	M8 x 1.25P	M12 x 1.75P	M16 x 2P	M20 x 2.5P	M20 x 2.5P
D7 <sub>h6</sub>	-	16	22	32	40	55	75
L1	42	62	76	105	142	180	220
L2	19.5	28.5	36	58	82	82	105
L3	6.5	20	20	30	30	30	33
L4	1	1.5	2	2	3	3	3
L5	16	25	32	40	63	70	90
L6	2	2	3	5	5	6	7
L7	4	6	7	10	12	15	20
L8	111.5	150	219	269.5	338.5	397	484
L9	42	60	90	115	142	180	220
L10	10	12.5	19	28	36	42	42
L11	-	26	26	26	40	41.5	52
L12	-	15	15	15	20	21.5	28
L13	-	21	22.5	23	33.5	33.5	45
C1 <sup>1</sup>	46	70	100	130	165	215	235
C2 <sup>1</sup>	M4 x 0.7P	M5 x 0.8P	M6 x 1P	M8 x 1.25P	M10 x 1.5P	M12 x 1.75P	M12 x 1.75P
C3 <sup>1</sup>	≤11 / ≤12 <sup>2</sup>	≤14 / ≤16 <sup>2</sup>	≤19 / ≤24 <sup>2</sup>	≤32	≤38	≤48	≤55
C4 <sup>1</sup>	25	34	40	50	60	85	116
C5 <sup>1</sup>	30	50	80	110	130	180	200
C6 <sup>1</sup>	3.5	8	4	5	6	6	6
C7 <sup>1</sup>	42	60	90	115	142	190	220
C8 <sup>1</sup>	29.5	19	17	19.5	22.5	29	63
C9 <sup>1</sup>	90.5	111.5	152.5	191.5	235.5	303.5	378.5
C10 <sup>1</sup>	8.75	13.5	10.75	13	15	20.75	53
B1 <sub>h9</sub>	5	5	6	10	12	16	20
H1	15	18	24.5	35	43	59	79.5
X DIN5480	-	W16x0.8x 30x18x6m	W22x1.25x 30x16x6m	W32x1.25x 30x24x6m	W40x2x 30x18x6m	W55x2x 30x26x6m	W70x2x 30x34x6m

1. C1~C10 are motor specific dimensions (metric std shown). Refer to [www.apexdyna.com](http://www.apexdyna.com) and Design Tool to view your specific motor mounting system.  
 2. AFR042M1 offers C3 ≤ 12 option; AFR060M1 offers C3 ≤ 16 option; AFR075M1 offers C3 ≤ 24 option.

# Dimensions (2-stage, Ratio i=12~200) / AFR Series

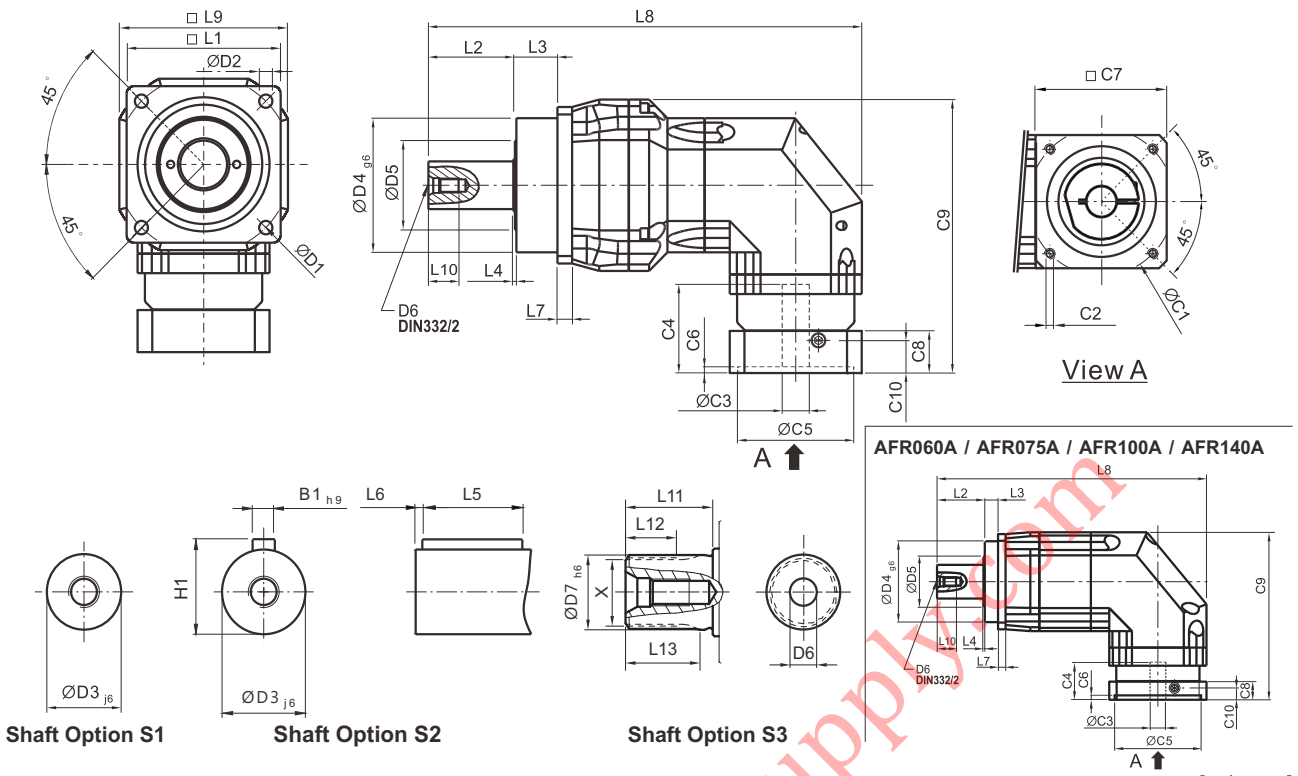

[unit: mm]

Dimension	AFR042	AFR060	AFR060A	AFR075	AFR075A	AFR100	AFR100A	AFR140	AFR140A	AFR180	AFR220
D1	50	68		85		120		165		215	250
D2	3.4	5.5		6.8		9		11		13	17
D3 <sub>j6</sub>	13	16		22		32		40		55	75
D4 <sub>g6</sub>	35	60		70		90		130		160	180
D5	22	45		60		80		75		95	115
D6	M4x0.7P	M5 x 0.8P		M8 x 1.25P		M12 x 1.75P		M16 x 2P		M20x2.5P	M20x2.5P
D7	-	16		22		32		40		55	75
L1	42	62		76		105		142		180	220
L2	19.5	28.5		36		58		82		82	105
L3	6.5	20		20		30		30		30	33
L4	1	1.5		2		2		3		3	3
L5	16	25		32		40		63		70	90
L6	2	2		3		5		5		6	7
L7	4	6		7		10		12		15	20
L8	139	168.5	187	222.5	267	295.5	330.5	370.5	410	434	521
L9	42	60		90		115		142		180	220
L10	10	12.5		19		28		36		42	42
L11	-	26		26		26		40		41.5	52
L12	-	15		15		15		20		21.5	28
L13	-	21		22.5		23		33.5		33.5	45
C1 <sup>3</sup>	46	46	70	70	100	100	130	130	165	165	215
C2 <sup>3</sup>	M4x0.7P	M4x0.7P	M5 x 0.8P	M5 x 0.8P	M6 x 1P	M6 x 1P	M8x1.25P	M8x1.25P	M10x1.5P	M10x1.5P	M12x1.75P
C3 <sup>3</sup>	≤11 / ≤12 <sup>4</sup>	≤11 / ≤12 <sup>4</sup>	≤14 / ≤16 <sup>4</sup>	≤14 / ≤15.875 / ≤16 <sup>4</sup>	≤19 / ≤24 <sup>4</sup>	≤19 / ≤24 <sup>4</sup>	≤32	≤32	≤38	≤38	≤48
C4 <sup>3</sup>	25	25	34	34	40	40	50	50	60	60	85
C5 <sup>3</sup>	30	30	50	50	80	80	110	110	130	130	180
C6 <sup>3</sup>	3.5	3.5	8	8	4	4	5	5	6	6	6
C7 <sup>3</sup>	42	42	60	60	90	90	115	115	142	142	190
C8 <sup>3</sup>	29.5	29.5	19	19	17	17	19.5	19.5	22.5	22.5	29
C9 <sup>3</sup>	90.5	99.5	111.5	126.5	152.5	165	191.5	205	235.5	254.5	323.5
C10 <sup>3</sup>	8.75	8.75	13.5	13.5	10.75	10.75	13	13	15	15	20.75
B1 <sub>h9</sub>	5	5		6		10		12		16	20
H1	15	18		24.5		35		43		59	79.5
X DIN5480	-	W16x0.8x 30x18x6m		W22x1.25x 30x16x6m		W32x1.25x 30x24x6m		W40x2x 30x18x6m		W55x2x 30x26x6m	W70x2x 30x34x6m

3. C1~C10 are motor specific dimensions (metric std shown). Refer to [www.apexdyna.com](http://www.apexdyna.com) and Design Tool to view your specific motor mounting system.

4. AFR042M1 offers C3 ≤ 12 option; AFR060/A M1 offers C3 ≤ 12/16 option; AFR075/A M1 offers C3 ≤ 16/24 option; AFR075 M2 offers C3 ≤ 15.875. AFR100M1 offers C3 ≤ 24 option.

# Selection of the Optimum Gearbox

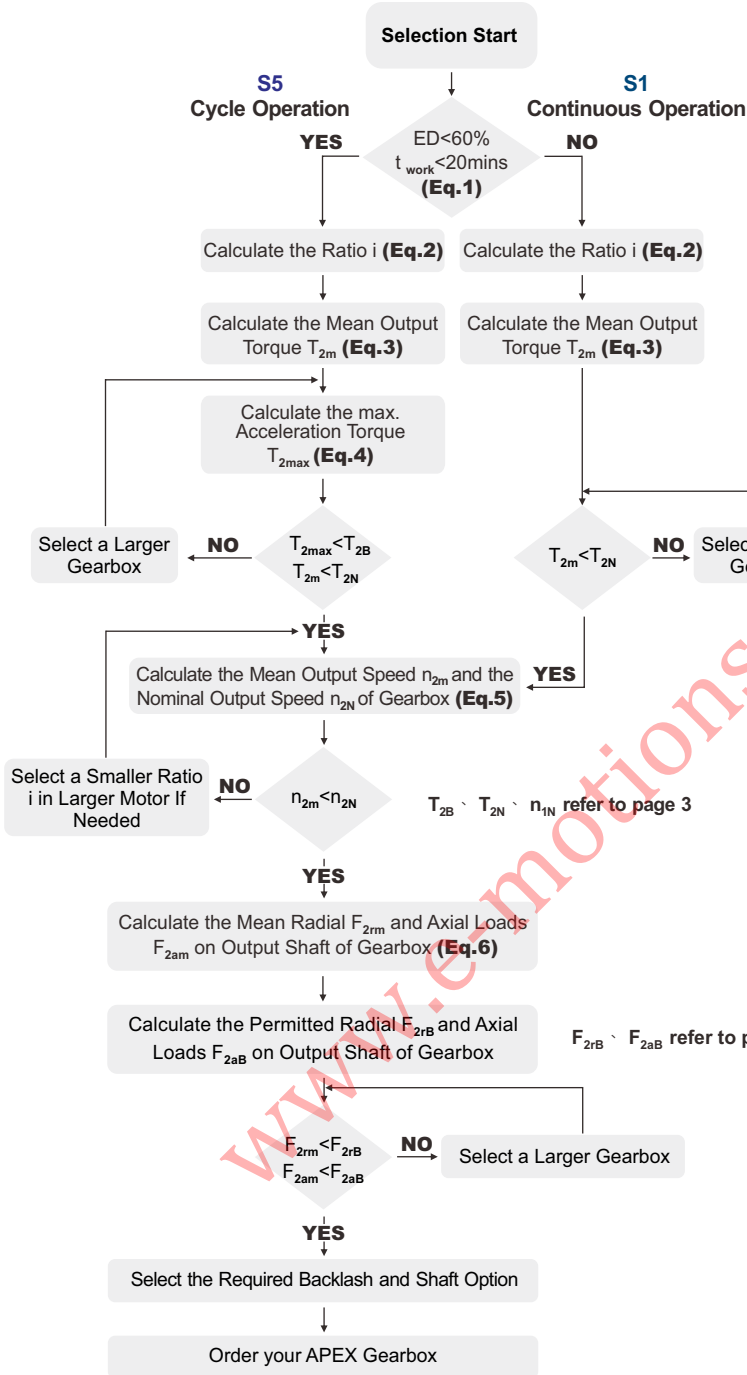

**Recommended (for S5 Cycle Operation)**

The general design is given for

$$\frac{J_L}{i^2} \leq 4 \times J_m$$

The optimal design is given for

$$\frac{J_L}{i^2} \cong J_m$$

$J_L$  Load Inertia  
 $J_m$  Motor Inertia

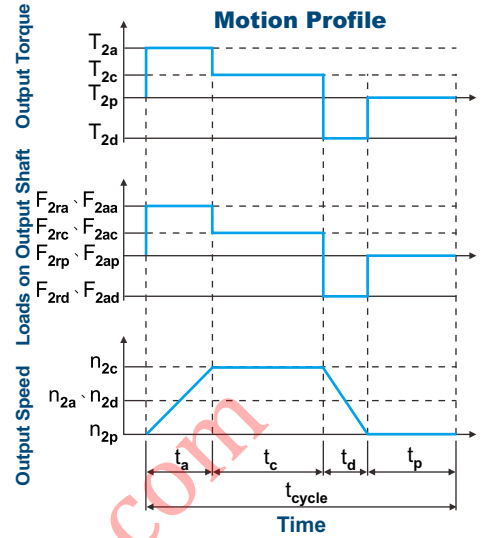

$$1. ED = \frac{t_a + t_c + t_d}{t_{cycle}} \times 100\%, t_{work} = t_a + t_c + t_d$$

Index : a. Acceleration, c. Constant, d. Deceleration, p. Pause (Eq.1)

$$2. i \cong \frac{n_m}{n_{work}}$$

$n_m$  Output Speed of the Motor  
 $n_{work}$  Working Speed (Eq.2)

$$3. T_{2m} = 3 \sqrt{\frac{n_{2a} \times t_a \times T_{2a}^3 + n_{2c} \times t_c \times T_{2c}^3 + n_{2d} \times t_d \times T_{2d}^3}{n_{2a} \times t_a + n_{2c} \times t_c + n_{2d} \times t_d}}$$

(Eq.3)

4.  $T_{2max} = T_{mB} \times i \times k_s \times \eta$   
 where  $K_s$  is

$K_s$	No. of Cycles / hr
1.0	0 ~ 1,000
1.1	1,000 ~ 1,500
1.3	1,500 ~ 2,000
1.6	2,000 ~ 3,000
1.8	3,000 ~ 5,000

$T_{mB}$  Max. Output Torque of the Motor  
 $\eta$  Efficiency of the Gearbox (Eq.4)

$$5. n_{2a} = n_{2d} = \frac{1}{2} \times n_{2c}$$

$$n_{2m} = \frac{n_{2a} \times t_a + n_{2c} \times t_c + n_{2d} \times t_d}{t_a + t_c + t_d}$$

$$n_{2N} = \frac{n_{1N}}{i}$$

(Eq.5)

$$6. F_{2rm} = 3 \sqrt{\frac{n_{2a} \times t_a \times F_{2ra}^3 + n_{2c} \times t_c \times F_{2rc}^3 + n_{2d} \times t_d \times F_{2rd}^3}{n_{2a} \times t_a + n_{2c} \times t_c + n_{2d} \times t_d}}$$

$$F_{2am} = 3 \sqrt{\frac{n_{2a} \times t_a \times F_{2aa}^3 + n_{2c} \times t_c \times F_{2ac}^3 + n_{2d} \times t_d \times F_{2ad}^3}{n_{2a} \times t_a + n_{2c} \times t_c + n_{2d} \times t_d}}$$

(Eq.6)

# Permitted Radial and Axial Loads

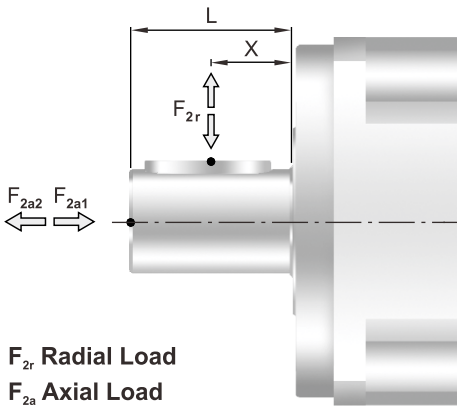

The permitted radial and axial loads on output shaft of the gearbox depend on the design of the gearbox supporting bearings. APEX use the extension straddle oversized ball bearing design. It can take heavy load from both axes.

$F_{2r}$  Radial Load  
 $F_{2a}$  Axial Load

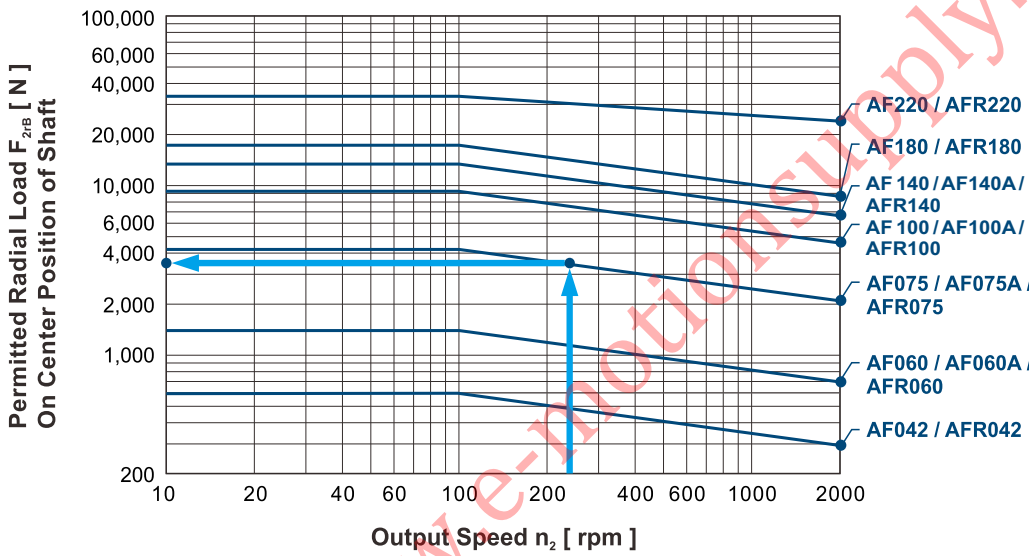

If radial force  $F_{2r}$  is exerted on the center of the output shaft  $X=1/2 \times L$ . The permitted radial load is given on left diagram.

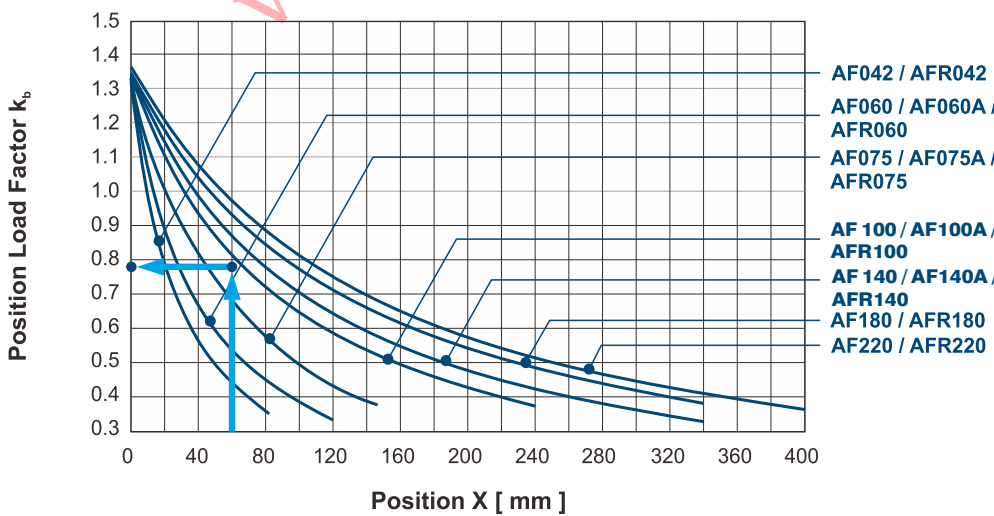

If radial force  $F_{2r}$  is not exerted on the center of the output shaft  $X < 1/2 \times L$  or  $X > 1/2 \times L$ . The permitted radial and axial loads can be calculated by the position load factor  $k_b$  on the left diagram.

# Note

[www.e-motionsupply.com](http://www.e-motionsupply.com)

# Note

[www.e-motionsupply.com](http://www.e-motionsupply.com)