

Golden Ding Series Analog Servo Drives



| Power Range | |
|--------------------|-------------|
| Peak Current | 40 A |
| Continuous Current | 20 A |
| Supply Voltage | 10 - 80 VDC |

Description

The CABH40A80X PWM servo drive is designed to drive brushless DC motors at a high switching frequency. The CABH40A80X is fully protected against over-voltage, under-voltage, over-current, over-heating, invalid commutation, and short-circuits. A single digital output indicates operating status. The drive interfaces with digital controllers that have analog $\pm 10V$ output. The CABH40A80X can utilize either Hall Sensor or Tachometer feedback for velocity control.

The CABH40A80X conforms to the following specifications and is designed to the Environmental Engineering Considerations as defined in MIL-STD-810F.s

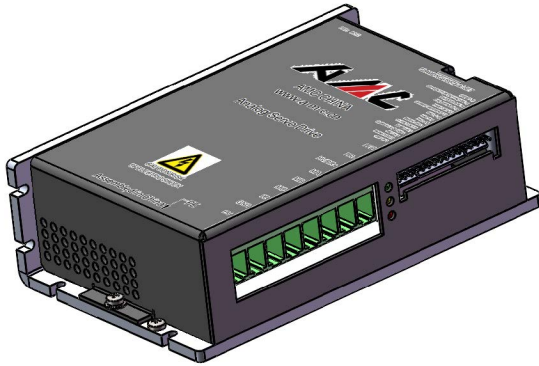

Extended Environment Performance

| | |
|---------------------|--|
| Ambient Temperature | -40°C to +85°C (-40°F to +185°F) |
| Storage Temperature | -50°C to +100°C (-58°F to +212°F) |
| Thermal Shock | -40°C to +85°C (-40°F to +185°F) in 2 min. |
| Relative Humidity | 0 to 95% Non-Condensing |
| Vibration | 30 Grms for 5 min. in 3 axes |



See Part Numbering Information on last page of datasheet for additional ordering options.

Features

- Four Quadrant Regenerative Operation
- Built-in regenerative and shunt regulator
- Lightweight
- High Switching Frequency
- Wide Temperature Range
- High Performance Thermal Dissipation
- Hall Velocity Mode
- Digital Fault Output Monitor
- 12VDC Operation
- Current Monitor Output
- Compact Size
- High Power Density

HARDWARE PROTECTION

- Over-Voltage
- Under-Voltage
- Over-Current
- Over-Temperature
- Short-circuit (phase-phase)
- Short-circuit (phase-ground)

INPUTS/OUTPUTS

- Digital Fault Output
- Digital Inhibit Input
- Analog Current Monitor
- Analog Command Input
- Analog Current Reference

COMMUTATION

- Trapezoidal

FEEDBACK SUPPORTED

- Hall Sensors
- Tachometer (± 60 VDC)

MODES OF OPERATION

- Current
- Duty Cycle (Open Loop)
- Hall Velocity
- Tachometer Velocity

MOTORS SUPPORTED

- Three Phase (Brushless)
- Single Phase (Brushed, Voice Coil, Inductive Load)

COMMAND SOURCE

- ± 10 V Analog

AGENCY APPROVALS & COMPLIANCE CONSIDERATIONS

- MIL-STD-810F (as stated)
- MIL-STD-1275D (optional)
- MIL-STD-461E (optional)
- MIL-STD-704F (optional)
- MIL-HDBK-217 (optional)

SPECIFICATIONS

| Power Specifications | | |
|---|---------|---|
| Description | Units | Value |
| DC Supply Voltage Range | VDC | 10 - 80 |
| DC Bus Under Voltage Limit | VDC | 9 |
| DC Bus Over Voltage Limit | VDC | 88 |
| Maximum Peak Output Current ¹ | A | 40 |
| Maximum Continuous Output Current | A | 20 |
| Maximum Continuous Output Power | W | 1520 |
| Maximum Power Dissipation at Continuous Current | W | 80 |
| Minimum Load Inductance (Line-To-Line) ² | μH | 100 |
| Internal Bus Capacitance ³ | μF | 530 |
| Low Voltage Supply Outputs | - | +6 VDC (30 mA) |
| Switching Frequency | kHz | 33 |
| Control Specifications | | |
| Description | Units | Value |
| Command Sources | - | ±10 V Analog |
| Feedback Supported | - | Halls, Tachometer (± 60 VDC) |
| Commutation Methods | - | Trapezoidal |
| Modes of Operation | - | Current, Hall Velocity, Duty Cycle, Tachometer Velocity |
| Motors Supported | - | Three Phase (Brushless), Single Phase (Brushed, Voice Coil, Inductive Load) |
| Hardware Protection | - | Invalid Commutation Feedback, Over Current, Over Temperature, Over Voltage, Short Circuit (Phase-Phase & Phase-Ground) |
| Mechanical Specifications | | |
| Description | Units | Value |
| Agency Approvals | - | MIL-STD-810F (as stated), MIL-STD-1275D (optional), MIL-STD-461E (optional), MIL-STD-704F (optional), MIL-HDBK-217 (optional) |
| Size (H x W x D) | mm | 145 x 92 x 44 |
| Baseplate Operating Temperature Range | °C (°F) | -40 - 105 (-40 - 221) |
| Ambient Temperature Range | °C (°F) | -40 - 85 (-40 - 185) |
| Storage Temperature Range | °C (°F) | -50 - 100 (-58 - 212) |
| Thermal Shock | °C (°F) | -40 - 85 (-40 - 185) in 2 minutes |
| Vibration | Grms | 30 for 5 minutes in 3 axes |
| Relative Humidity | - | 0 - 95% Non-Condensing |
| P1 Connector | - | 16 Pin, pitch 2.54 mm connector |
| P2 Connector | - | 8Pin pitch 7.62 mm Pluggable terminal block |

Notes

1. Maximum duration of peak current is ~2 seconds. Peak RMS value must not exceed continuous current rating of the drive.
2. Lower inductance is acceptable for bus voltages well below maximum. If the motor inductance is lower than the minimum inductance, please contact the factory for customized modification.

BLOCK DIAGRAM

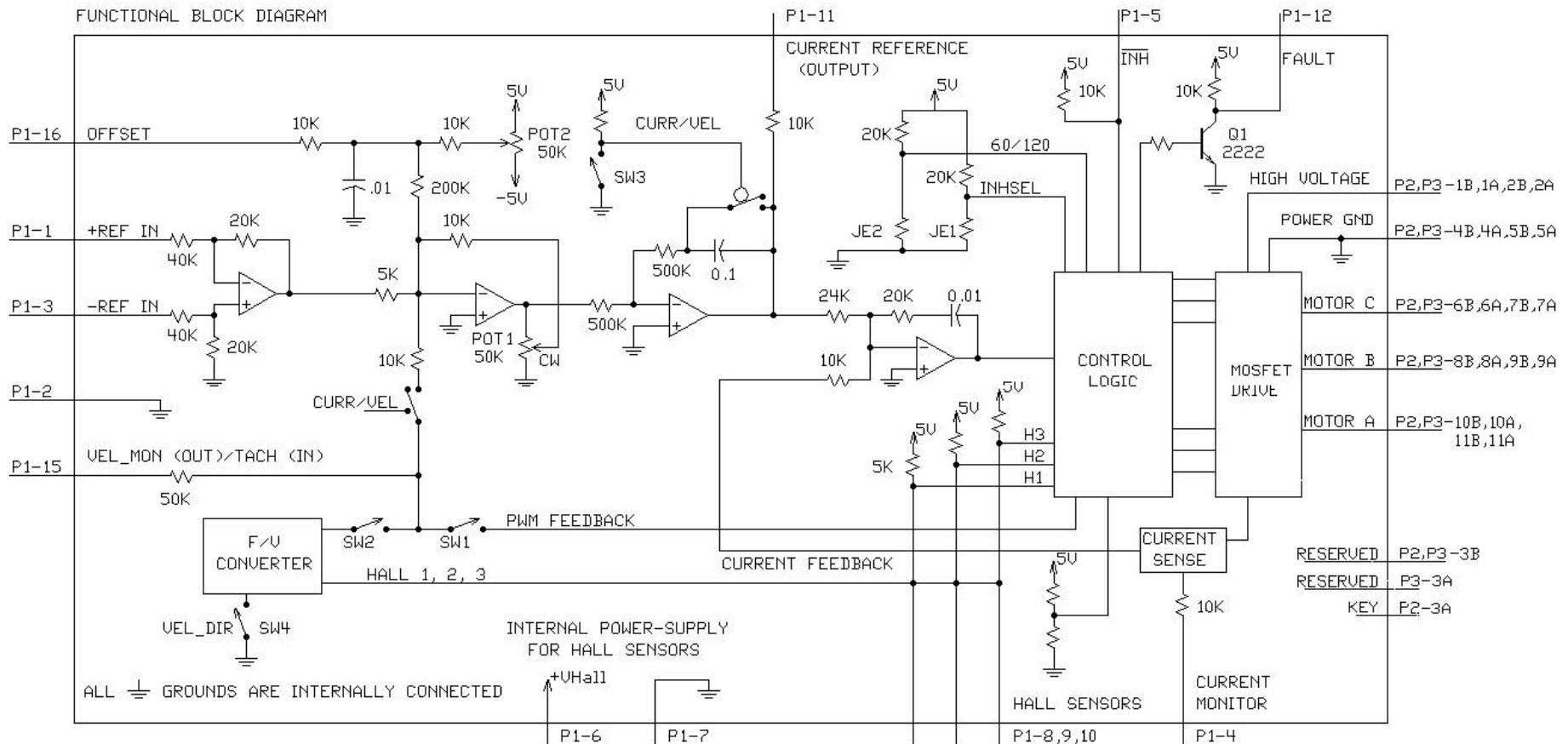

Information on Approvals and Compliances

| | |
|---------------|---|
| MIL-STD-810F | Environmental Engineering Considerations and Laboratory Tests - (as stated) |
| MIL-STD-1275D | Characteristics of 28 Volt DC Electrical Systems in Military Vehicles - (optional) |
| MIL-STD-461E | Requirements for the Control of Electromagnetic Interference Characteristics of Subsystems and Equipment - (optional) |
| MIL-STD-704F | Aircraft Electric Power Characteristics - (optional) |
| MIL-HDBK-217 | Reliability Prediction of Electronic Equipment (MTBF) - (optional) |

HARDWARE SETTINGS

Switch Functions

The DIP Switch bank is located on the underside of the drive. The tables below describe switch functionality.

| Switch | Description | Setting | |
|--------|--|-----------------|-------------|
| | | On | Off |
| 1 | Duty Cycle mode selector. Activates internal PWM feedback. | Duty Cycle mode | Other modes |
| 2 | Activate velocity feedback or monitor. For Encoder Velocity mode, activates feedback. For Current mode, activates velocity monitor. | Active | Inactive |
| 3 | Current mode selector. | Current mode | Other modes |
| 4 | Velocity feedback polarity. Changes the polarity of the internal feedback signal and the velocity monitor output signal. Inversion of the feedback polarity may be required to prevent a motor run-away condition. | Standard | Inverted |

Mode Selection Table

| | SW1 | SW2 | SW3 |
|---------------------|-----|-----|-----|
| CURRENT | OFF | ON | ON |
| DUTY CYCLE | ON | OFF | OFF |
| ENCODER VELOCITY* | OFF | ON | OFF |
| TACHOMETER VELOCITY | OFF | OFF | OFF |

*NOTE: See details of switch 4 for further Encoder Velocity configuration information.

Jumper Settings

Jumpers are SMT, 0 ohm resistors located on the underside of the drive PCB. By default, the drive is configured with the jumpers installed. Typical drive operation will not require the jumpers to be removed. Please contact the factory before jumper removal.

| Jumper | Description SMT Jumper (0Ω Resistor) | Configuration | |
|--------|---|---------------|-------------|
| | | Not Installed | Installed |
| JE1 | Inhibit logic. Sets the logic level of inhibit pins. Labeled JE1 on the PCB of the drive. | Low Enable | Low Inhibit |
| JE2 | Hall sensor phasing. Selects 120 or 60 degree commutation phasing. Labeled JE2 on the PCB of the drive. | 60 degree | 120 degree |

Potentiometer Functions

Potentiometers are located between the PCB and the drive baseplate, and are accessible from the side. Potentiometers are approximately linear and have 12 active turns with 1 inactive turn on each end.

| Potentiometer | Description | Turning CW |
|---------------|--|--------------------------------------|
| 1 | Loop gain adjustment for duty cycle / velocity modes. Turn this pot fully CCW in current mode. Located closest to the corner of the PCB. | Increases gain |
| 2 | Offset. Used to adjust any imbalance in the input signal or in the amplifier. Located furthest from the corner of the PCB. | Adjusts offset in negative direction |

PIN FUNCTIONS

| P1 Signal Interface Definitions | | |
|---------------------------------|---------------------------|--|
| Connector information | | 16 Pin, pitch 2.54 mm connector |
| Matching Connector | Part No. | Molex: P/N 22-01-3167 (Housings) and P/N 08-50-0114 (CRIMP TERMINAL) |
| | Remark | Connectors need to be ordered separately |
| Pin | Signal | Description |
| 1 | +REF IN | Differential Reference Input (± 10 V Operating Range, ± 15 V Maximum Input) |
| 2 | SIGNAL GND | Signal Ground |
| 3 | -REF IN | Differential Reference Input (± 10 V Operating Range, ± 15 V Maximum Input) |
| 4 | CURRENT MONITOR | Current Monitor. Analog output signal proportional to the actual current output. Polarity is reversed from command voltage. Scaling is 5.13 A/V. Measure relative to signal ground. |
| 5 | INHIBIT IN | TTL level (+5 V) inhibit/enable input. Leave open to enable drive. Pull to ground to inhibit drive. Inhibit turns off all power devices. |
| 6 | +V HALL OUT | Low Power Supply For Hall Sensors (+6 V @ 30 mA). Referenced to signal ground. Short circuit protected. |
| 7 | SIGNAL GND | Signal Ground |
| 8 | HALL 1 | Single-ended Hall/Commutation Sensor Inputs (+5 V logic level) |
| 9 | HALL 2 ¹ | |
| 10 | HALL 3 | |
| 11 | CURRENT REFERENCE | Measures the command signal to the internal current-loop. This pin has a maximum output of ± 7.3 V when the drive outputs maximum peak current. Measure relative to signal ground. |
| 12 | FAULT OUT | TTL level (+5 V) output becomes high when power devices are disabled due to at least one of the following conditions: inhibit, invalid Hall state, output short circuit, over voltage, over temperature, power-up reset. |
| 13 | NC | Not Connected (Reserved) |
| 14 | NC | Not Connected (Reserved) |
| 15 | VEL MONITOR OUT / TACH IN | Velocity Monitor. Analog output proportional to motor speed. In Hall Velocity mode, output is proportional to the electrical cycle frequency. Hall Velocity scaling is 100 Hz/V. For Tachometer Velocity mode, feedback voltage range is ± 60 VDC max. |
| 16 | OFFSET | Connection to external resistance for command offset adjustments. Apply a \pm VDC (10V Max) signal through an external potentiometer into this pin to offset the input gain. |

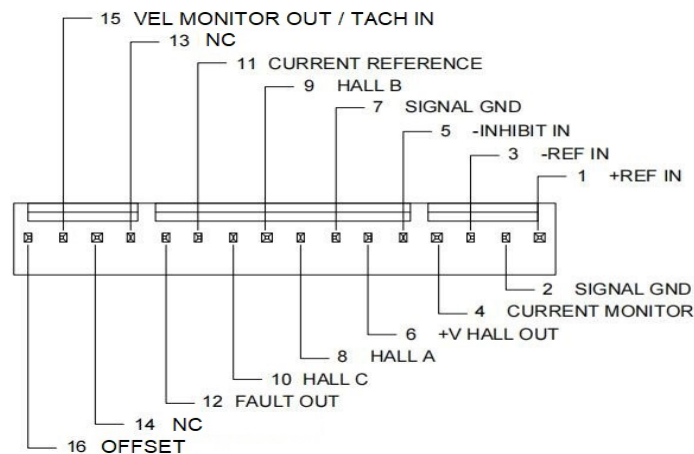

- For use with Single Phase (Brushed) motors, ground Hall 2 and only connect motor leads to Motor A and Motor B.

| P2 Power Interface Definitions | | |
|--------------------------------|----------|---|
| Connector information | | 8Pin pitch 7.62 mm Pluggable terminal block |
| Matching Connector | Part No. | KF2EDGSK-7.62mm/KF2EDGAK-7.62mm |
| | Remark | Connectors need to be ordered separately |
| Pin | Signal | Description |
| 1 | HV | DC+ Power Input |
| 2 | GND | Power Ground (Common With Signal Ground). |
| 3 | PE | Protective ground (Connect motor cable shield) |
| 4 | MC | Motor Phase W |
| 5 | MB | Motor Phase V |
| 6 | MA | Motor Phase U |
| 7 | HV/BR+ | External braking resistor connection. Connect a resistor between BR+ and BR-. |
| 8 | BR- | |

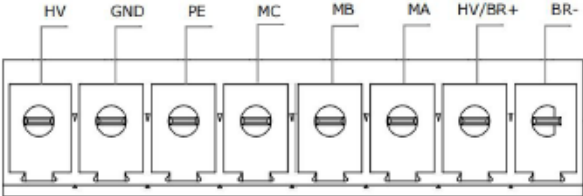

Golden Ding Series Analog Servo Drives



DIMENSIONS (mm)

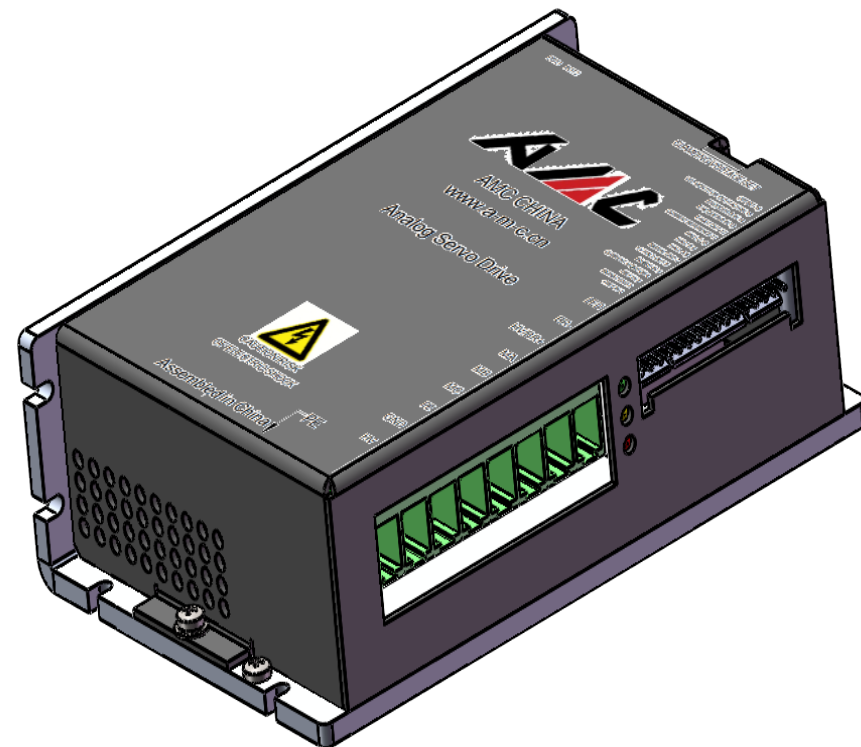
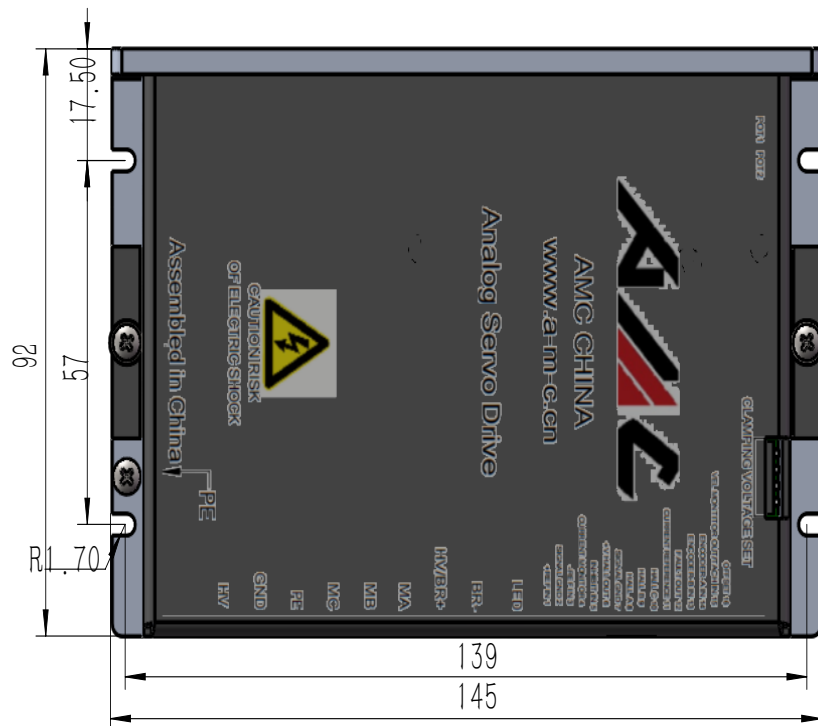
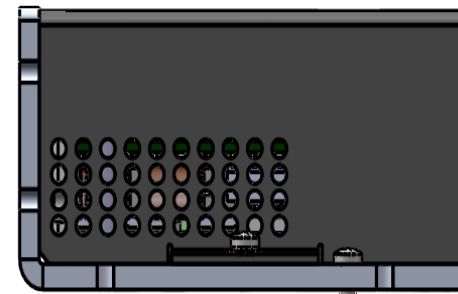
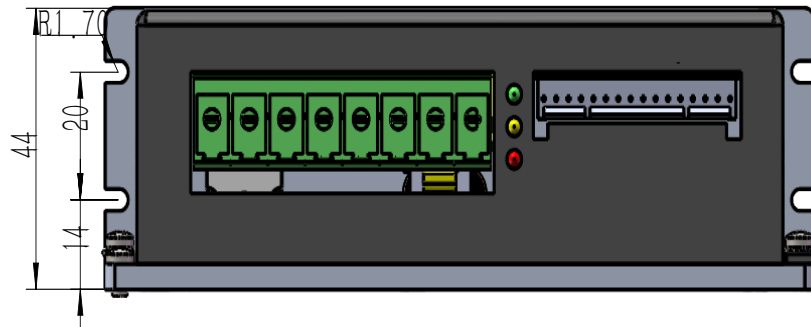

PART NUMBERING INFORMATION

