

GLENTEK DC BRUSH SERVO MOTORS GM3300 SERIES

Revision: 3/24/2017



Glentek's GM3300 series of high performance, permanent magnet DC brush servo motors utilize traditional ferrite magnets, which are ideal for cost sensitive applications. In addition, the higher inertia armatures provide improved motor to load inertia matching for medium to high inertia loads. This helps to reduce the mechanical shaft resonance, which allows higher servo gains with increased stability. These motors incorporate skewed armatures, which provide ultra smooth operation (i.e. low cogging torque) at all speeds.

- Continuous Torque Range:
4.4 Lb-in (0.5 Nm) to 10.6 Lb-in (1.2 Nm)
- Peak Torque Range:
22.0 Lb-in (2.5 Nm) to 53.0 Lb-in (5.99 Nm)

GM3300 SERIES FEATURES

Skewed armature design provides ultra smooth operation (i.e. low cogging torque) at all speeds.
Various electrical windings are available as standard to suit both low and high voltage amplifiers in order to provide optimum speed and torque characteristics. Optional custom electrical windings are available to meet virtually any requirement.
Worldwide standard mounting configurations are available (Square, Round, and NEMA 34). Optional custom mounting configurations are available to meet virtually any requirement.
Industry standard lead termination configurations. (i.e. MS connectors, fluid tight strain relief cable exit, NPT hole with flying leads and terminal boxes)
Optional industry standard feedback devices. (i.e. high performance silver commutator tachometers, and encoders)
Class H insulation standard.
Standard operating temperature is dependent on the feedback device installed. Motors with resolver feedback can be specially configured to operate down to -40°C.
Optional 24VDC holding brakes are available.
Optional IP65 sealing is available
CSA and UL recognized.
CE marked.
UL Recognized Component for US and Canada.

GM3300 SERIES ENVIRONMENTAL CONDITIONS

Storage Temperature:	-20°C to 70°C
Operating Temperature:	Standard: -20°C to 40°C, without derating, derate torque 10% per 10°C above 40°C Special: -40°C to 40°C, without derating, derate torque 10% per 10°C above 40°C
Humidity:	5% to 95% relative humidity, non-condensing
Altitude:	Up to 1000m without derating, derate torque 10% per 1000m above 1000m

GM3300 SERIES SELECTION TABLE

K_T = Torque Constant • K_V = BEMF = Volts/1000 RPM • L_A = Inductance

Model Number	Power @ Max Speed		Cont. Stall Rating			Peak Stall Rating			K_T		R_A	L_A	RPM	K_V	Armature Inertia	
	HP	KW	Lb-in	Nm	Amps	Lb-in	Nm	Amps	Lb-in/A	Nm/A	Ω	mH	Max	V/Krpm	Lb-in-sec ²	Kg-m ²
GM3310-25	0.24	0.179	4.4	0.50	2.1	22.0	2.50	10.5	2.1	0.24	6.5	9.00	3400	25	0.00192	0.000217
GM3320-22	0.42	0.313	7.5	0.85	4.4	37.5	4.24	22.0	1.70	0.19	2.1	4.00	3500	22	0.00208	0.000235
GM3320-30	0.38	0.283	7.5	0.85	3.0	37.5	4.24	15.0	2.50	0.28	3.2	9.00	3200	30	0.00208	0.000235
GM3340-22	0.59	0.44	10.6	1.20	6.3	53.0	5.99	31.5	1.69	0.19	1.0	2.00	3500	22	0.00310	0.000350
GM3340-27	0.56	0.414	10.6	1.20	4.2	53.0	5.99	23.6	2.25	0.25	1.3	2.40	3300	27	0.00310	0.000350
GM3340-30	0.54	0.403	10.6	1.20	4.2	53.0	5.99	21.0	2.53	0.29	2.0	2.70	3200	30	0.00310	0.000350

NOTE: All ratings based on a 40°C ambient temperature with the motor face mounted to a 12" x 12" x 1/2" aluminum heatsink.

GM3300 SERIES DIMENSIONS

C1 = Bare Motor, C2 = Motor with Tachometer or Encoder, C3 = Motor with Tachometer and Encoder.

Note: Dimensions are in inches (mm)

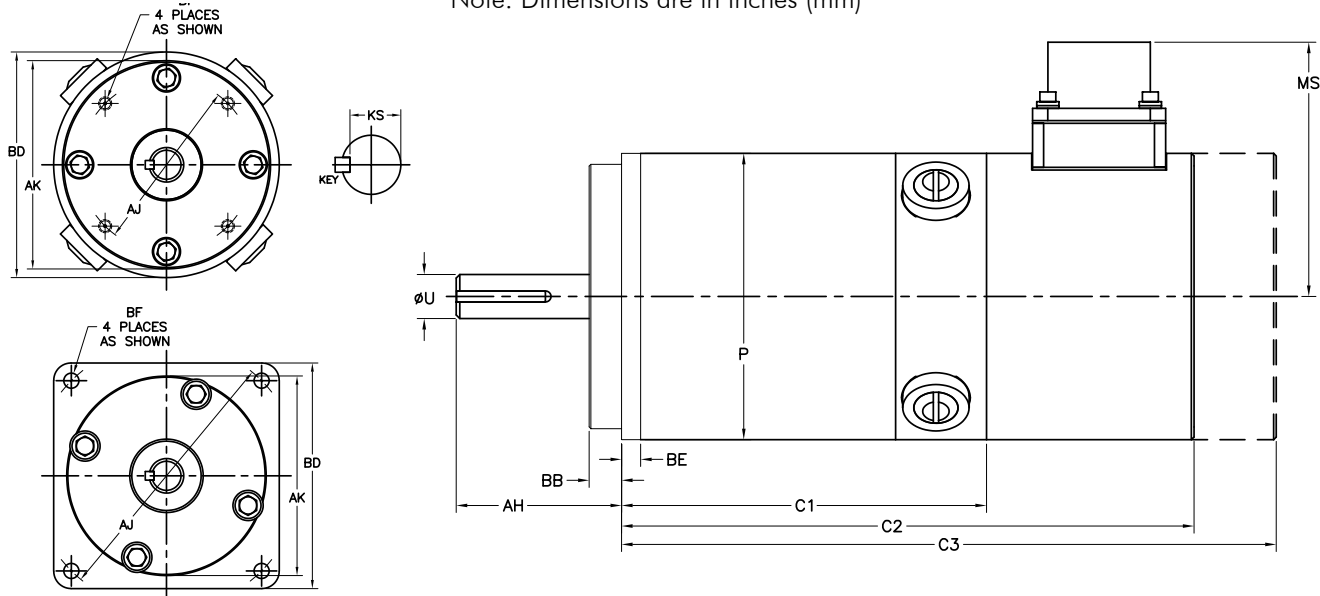

Model Number	Lbs (kg)	C1		C2		C3		P	Connectors	MS
		RND	SQR	RND	SQR	RND	SQR			
GM3310	5.0 (2.3)	3.72 (94.49)	3.98 (101.09)	6.45 (163.83)	6.71 (170.43)	7.71 (195.83)	7.97 (202.44)	3.25 (82.55)	6-Pin	2.689 (68.3)
GM3320	7.0 (3.2)	4.34 (110.24)	4.61 (117.09)	7.07 (186.58)	7.34 (186.44)	8.33 (211.58)	8.60 (218.44)	3.25 (82.55)	14-Pin	2.886 (73.3)
GM3330	8.0 (3.6)	5.65 (143.51)	5.92 (150.37)	8.38 (212.85)	8.65 (219.71)	9.64 (244.86)	9.91 (251.71)	3.25 (82.55)	16-Pin	2.979 (75.7)
GM3340	10.0 (4.5)	6.31 (160.27)	6.57 (166.88)	9.04 (229.62)	9.30 (236.22)	10.30 (261.62)	10.56 (268.22)	3.25 (82.55)	Liquid Tight	2.691 (68.35)

Flange Type	Shaft				Flange/Face				Mounting Hole		
	AH	U (MAX)	KEY	KS	AJ	AK	BB	BD	BE (MAX)	BF Dia.	Tap
Round	1.87 (47.50)	0.5000 (12.70)	0.125 SQ. X 1.00	0.420- 0.430	2.500 (63.50)	3.000 (76.20)	0.37 (9.40)	3.25 (82.55)	0.22 (5.59)	-	10-32 ∇.50
Square Flange	1.60 (40.64)	0.5000 (12.70)	0.125 SQ. X 1.00	0.420- 0.430	3.875 (98.43)	2.875 (73.03)	0.10 (2.54)	3.25 (82.55)	0.48 (12.19)	0.22 (5.59)	THRU
NEMA 34	1.19 (30.23)	0.3750 (9.53)	-	-	3.875 (98.43)	2.875 (73.03)	0.10 (2.54)	3.25 (82.55)	0.48 (12.19)	0.22 (5.59)	THRU

BRAKE OPTION

Brake requires 24V DC input voltage. The values for "Extension" represent the nominal maximum length that the brake will add to the motor. For some models, the extension will be less. Please contact one of our sales engineers for the exact values.

Extension	Torque		Power
in. (mm)	Lb-in	Nm	Watts
1.91 (49)	39.8	4.5	12

CONNECTORS & PIN-OUT INFORMATION

With a positive voltage applied to the red motor lead (Motor +) with respect to the black motor lead (Motor -), the motor drive shaft will turn in the clockwise direction as viewed from the shaft end.

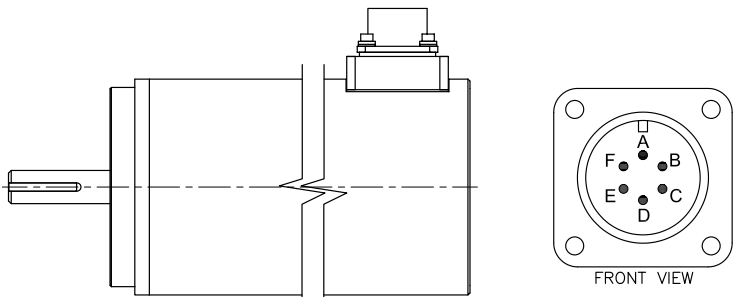
GM 3300 Series Standard 6-pin MS Connector Location	MS3102R-14-6P	Function
 <p style="text-align: center;">FRONT VIEW</p> <ul style="list-style-type: none"> •Straight Mating Connector: MS3106F-20-27S •90° Mating Connector: MS3108E-20-27S 	6-Pin	
	A	Motor +
	B	Motor -
	C	Tachometer +
	D	Tachometer -
	E (W/O Brake) E (W/ Brake)	Tachometer Cable Shield
	F	Brake + Brake -

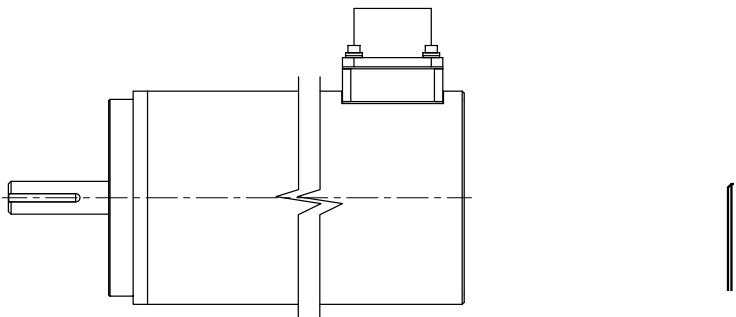
GM 3300 Series Standard 14-pin MS Connector Location	MS3102R-20-27P	Encoder Feedback	Resolver Feedback
 <p style="text-align: center;">FRONT VIEW</p> <ul style="list-style-type: none"> •Straight Mating Connector: MS3106F-20-27S •90° Mating Connector: MS3108E-20-27S 	14-Pin	Function	Function
	A	Channel A+	Sine Sig (S1)
	B	Channel A-	Sine Com (S2)
	C	Channel B+	Cosine Sig (S3)
	D	Channel B-	Cosine Com (S4)
	E	Channel Z+	Reference Sig (R1)
	F	Channel Z-	Reference Com (R2)
	G	+5 VDC	N/C
	H	Common	N/C
	I	Cable Shield	N/C
	J	Tachometer +	Tachometer -
	K	Tachometer -	Tachometer Cable Shield
	L	Tachometer Cable Shield	Brake +
	-	Brake +	Motor +
	N	Motor +	Brake -
	-	Brake -	Motor -
	P	Motor -	

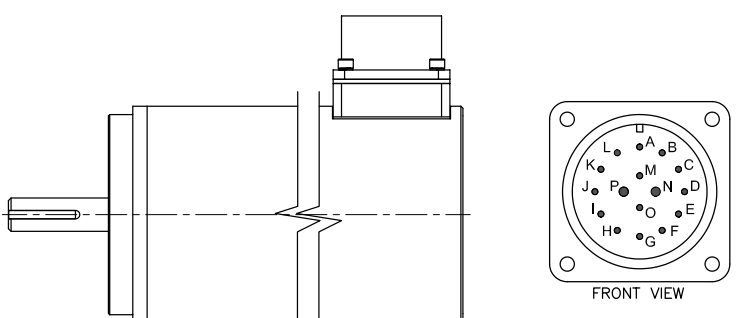
GM 3300 Series Standard 16-pin MS Connector Location	MS3102R-24-07P	Encoder Feedback	Resolver Feedback
 <p style="text-align: center;">FRONT VIEW</p> <ul style="list-style-type: none"> •Straight Mating Connector: MS3106F-20-27S •90° Mating Connector: MS3108E-20-27S 	16-Pin	Function	Function
	A	Channel A+	Sine Sig (S1)
	B	Channel A-	Sine Com (S2)
	C	Channel B+	Cosine Sig (S3)
	D	Channel B-	Cosine Com (S4)
	E	Channel Z+	Reference Sig (R1)
	F	Channel Z-	Reference Com (R2)
	G	+5 VDC	N/C
	H	Common	N/C
	I	Cable Shield	N/C
	J	Tachometer +	Tachometer -
	K	Tachometer -	Tachometer Cable Shield
	L	Tachometer Cable Shield	Brake +
	M	Brake +	Motor +
	N	Motor +	Brake -
	O	Brake -	Motor -
	P	Motor -	

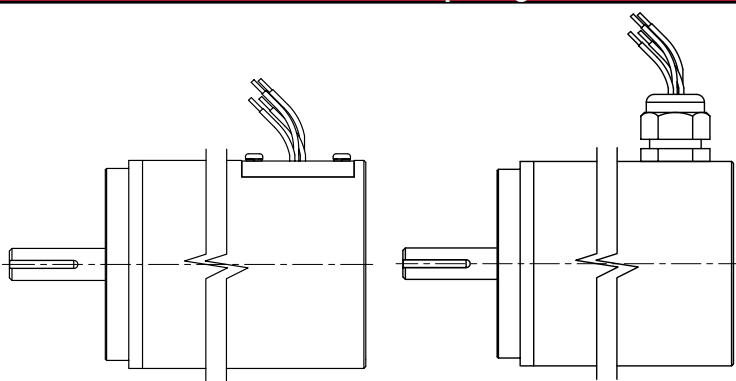
GM 3300 Series standard NPT & Liquid Tight Strain Relief	
 <p style="text-align: center;">Standard NPT Liquid Tight Strain Relief</p>	<p>Glentek's GM3300 Series offer Special mounting options please contact a Glentek Sales Engineer for detailed information.</p>

GM3310-25 PERFORMANCE DATA

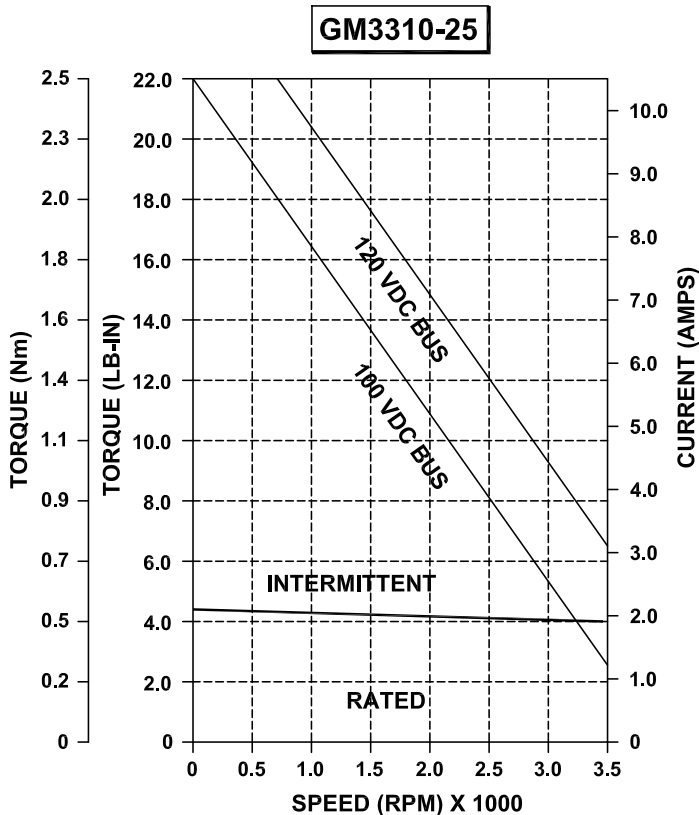

Power @ Max Speed	HP	0.24
	KW	0.179
Cont. Stall Rating	Lb-in	4.4
	Nm	0.50
	Amps	2.1
Peak Stall Rating	Lb-in	22.0
	Nm	2.50
	Amps	10.5
Torque Constant	Lb-in/A	2.1
	Nm/A	0.24
Resistance	Ohms	6.5
Inductance	mH	9.0
Maximum Speed	RPM	3400
Back EMF	V/Krpm	25
Armature Inertia	Lb-in-sec²	0.00192
	Kg-m²	0.00217

GM3320-22 PERFORMANCE DATA

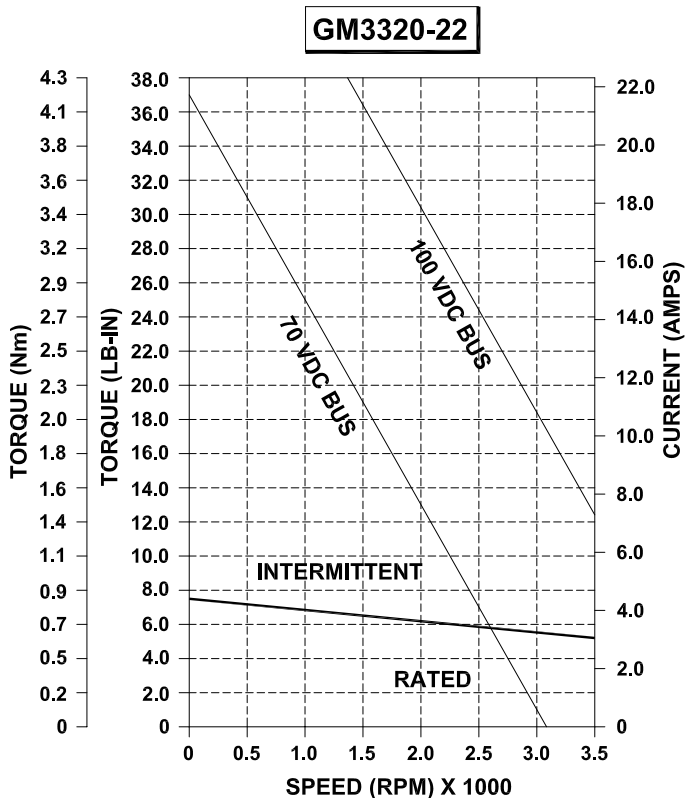

Power @ Max Speed	HP	0.42
	KW	0.313
Cont. Stall Rating	Lb-in	7.5
	Nm	0.85
	Amps	4.4
Peak Stall Rating	Lb-in	37.5
	Nm	4.24
	Amps	22.0
Torque Constant	Lb-in/A	1.7
	Nm/A	0.19
Resistance	Ohms	2.1
Inductance	mH	4.0
Maximum Speed	RPM	3500
Back EMF	V/Krpm	22
Armature Inertia	Lb-in-sec²	0.00208
	Kg-m²	0.000235

NOTE: All ratings based on a 40°C ambient temperature with the motor face mounted to a 12" x 12" x 1/2" aluminum heatsink.

GM3320-30 PERFORMANCE DATA

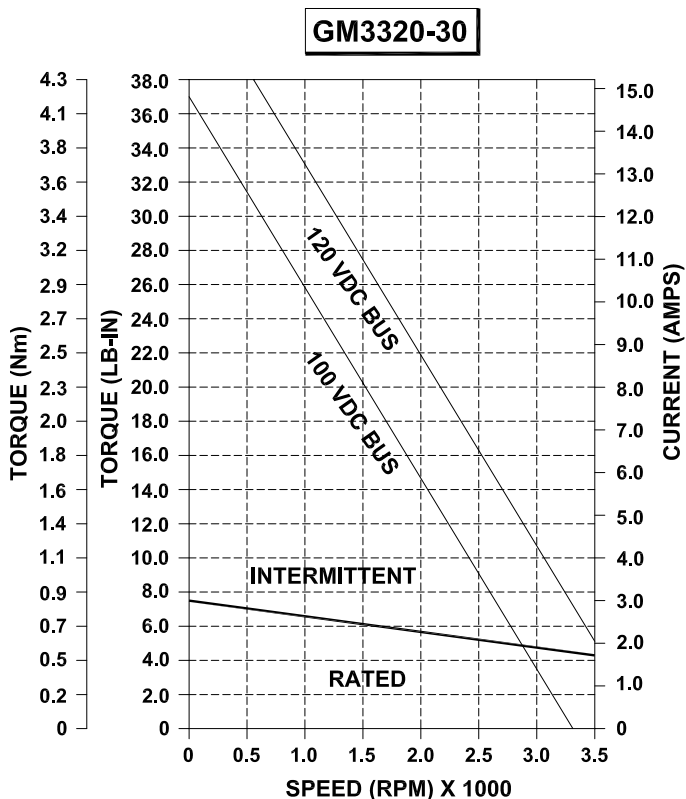

Power @ Max Speed	HP	0.38
	KW	0.283
Cont. Stall Rating	Lb-in	7.5
	Nm	0.85
	Amps	3.0
Peak Stall Rating	Lb-in	37.5
	Nm	4.24
	Amps	15.0
Torque Constant	Lb-in/A	2.5
	Nm/A	0.28
Resistance	Ohms	3.2
Inductance	mH	9.0
Maximum Speed	RPM	3200
Back EMF	V/Krpm	30
Armature Inertia	Lb-in-sec²	0.00208
	Kg-m²	0.000235

GM3340-22 PERFORMANCE DATA

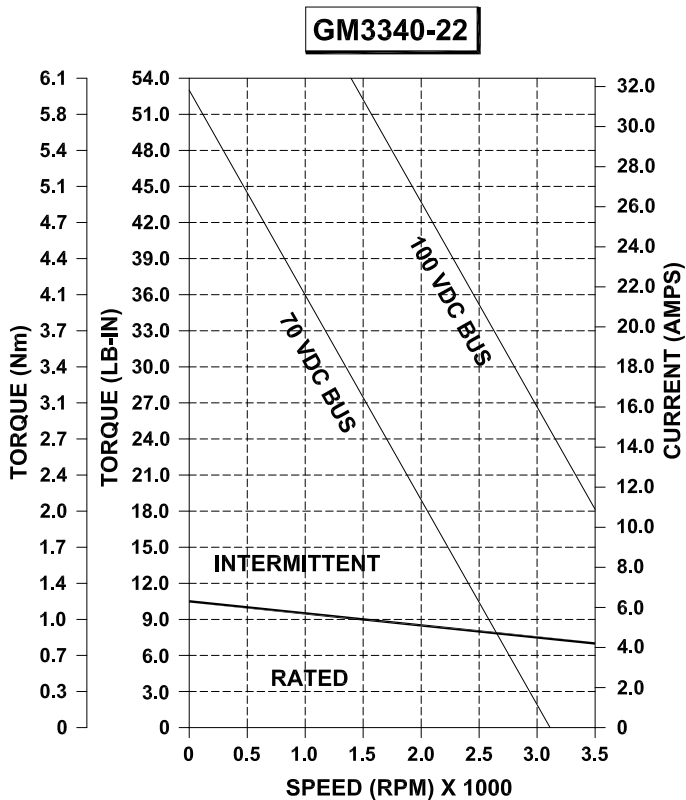

Power @ Max Speed	HP	0.59
	KW	0.44
Cont. Stall Rating	Lb-in	10.6
	Nm	1.2
	Amps	6.3
Peak Stall Rating	Lb-in	53.0
	Nm	5.99
	Amps	31.5
Torque Constant	Lb-in/A	1.69
	Nm/A	0.19
Resistance	Ohms	1.0
Inductance	mH	2.0
Maximum Speed	RPM	3500
Back EMF	V/Krpm	22
Armature Inertia	Lb-in-sec²	0.0031
	Kg-m²	0.00035

NOTE: All ratings based on a 40°C ambient temperature with the motor face mounted to a 12" x 12" x 1/2" aluminum heatsink.

GM3340-27 PERFORMANCE DATA

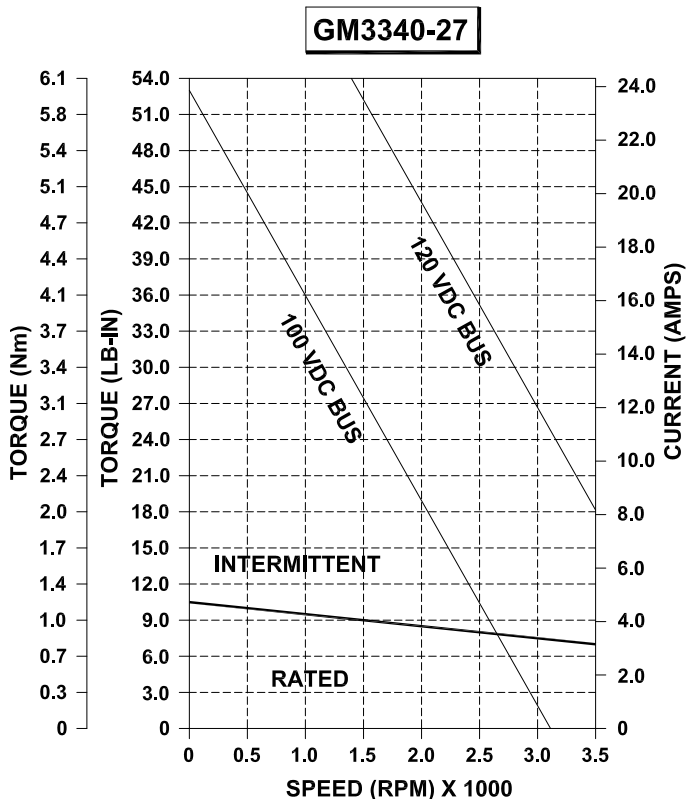

Power @ Max Speed	HP	0.56
	KW	0.414
Cont. Stall Rating	Lb-in	10.6
	Nm	1.2
	Amps	4.7
Peak Stall Rating	Lb-in	53.0
	Nm	5.99
	Amps	23.6
Torque Constant	Lb-in/A	2.25
	Nm/A	0.25
Resistance	Ohms	1.3
Inductance	mH	2.4
Maximum Speed	RPM	3300
Back EMF	V/Krpm	27
Armature Inertia	Lb-in-sec²	0.0031
	Kg-m²	0.00035

GM3340-30 PERFORMANCE DATA

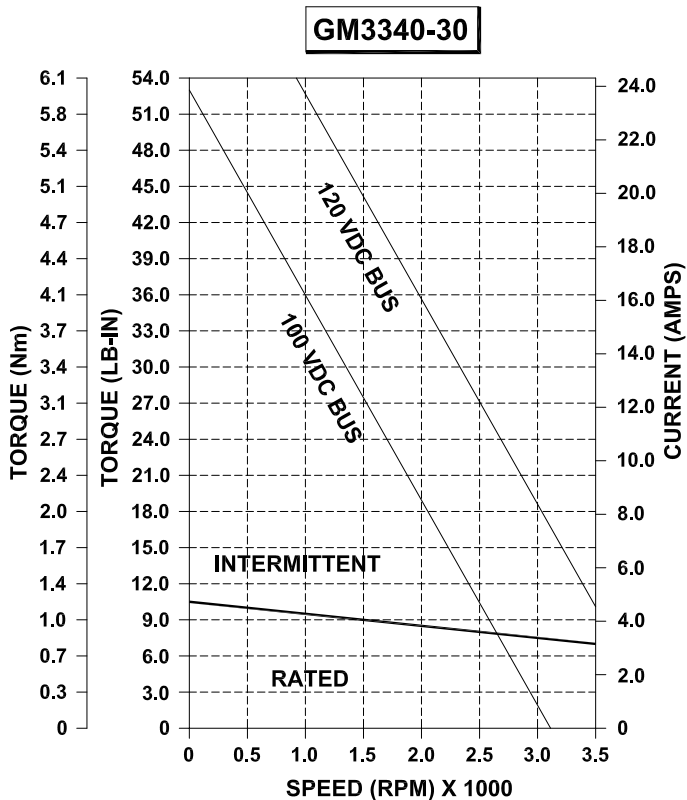

Power @ Max Speed	HP	0.54
	KW	0.403
Cont. Stall Rating	Lb-in	10.6
	Nm	1.2
	Amps	4.2
Peak Stall Rating	Lb-in	53.0
	Nm	5.99
	Amps	21.0
Torque Constant	Lb-in/A	2.53
	Nm/A	0.29
Resistance	Ohms	2.0
Inductance	mH	2.7
Maximum Speed	RPM	3200
Back EMF	V/Krpm	30
Armature Inertia	Lb-in-sec²	0.0031
	Kg-m²	0.00035

NOTE: All ratings based on a 40°C ambient temperature with the motor face mounted to a 12" x 12" x 1/2" aluminum heatsink.

GM3300 SERIES MODEL NUMBERING

This section explains the model numbering system for Glentek's GM3300 Series DC Brush Servo Motors. The model numbering system is designed so that you, our customer, will be able to quickly and accurately create the model number for the drive that best suits your requirements. Please complete the drive configuration code you require using the information on this page. After completing your model number, please contact a Glentek Sales Engineer to confirm that the model number you have created is correct.

GM
33
20
-
22
-
0
2
8
0
1
5
0
0
-

- Frame Size** 33 = 3.3" Motor
- Stack Length** 20 = 2.0 inch stack
- Back EMF Constant** 22 = 22 V/Krpm
- Brake Option** 0 = No brake installed
- Tachometer Option** 2 = 7 VDC tachometer
- Encoder Option** 8 = 2500 PPR
- Brushless Resolver Option** 0 = No resolver installed
- Flange Type** 1 = Standard Square
- Lead Termination** 5 = Male MS connector, MS3102R-24-07P (16-pin style)
- Wiring Diagram** 0 = Glentek Standard
- Sealing Option** 0 = No shaft seal
- Factory Assigned Option** Leave blank

GM

-

-

-

Frame Size	
33	3.3" Motor

Stack Length			
10	1.0 inch Stack	40	4.0 inch stack
20	2.0 inch Stack		

Back EMF Constant					
1.0" only		2.0" only		4.0" only	
25	25 V/Krpm	22	22 V/Krpm	22	22 V/Krpm
		30	30 V/Krpm	27	27 V/Krpm
		-	-	30	30 V/Krpm
For custom Back EMF, Please Contact Glentek					

Brake Option					
0	No brake installed	1	24 VDC Brake	2	Special

Tachometer Option					
0	No tachometer installed	2	7 VDC tachometer	4	Special
1	3 VDC tachometer	3	9.5 VDC tachometer	-	-

Encoder Option					
0	No encoder installed	4	1000 PPR	8	2500 PPR
2	500 PPR	6	2000 PPR	9	Special

Brushless Resolver Option					
0	No resolver installed	1	Brushless resolver	2	Special

Flange Type					
0	Standard Round	6	Special		
1	Standard Square	8	NEMA 34		

Lead Termination					
0	Flying leads exiting through a rubber grommet	4	14-Pin, Male MS connector		
1	.5" NPT with flying leads	5	16-Pin, Male MS connector		
2	.75" NPT with flying leads	6	Liquid tight strain relief with flying leads		
3	6-Pin, Male MS connector	8	Special		

Wiring Diagram (MS conector lead termination only)					
0	Glentek Standard	1	Special		

Sealing Option					
0	No shaft seal	1	Shaft Seal	2	Special

Factory Assigned Option

A numerical code will be assigned by Glentek to motors whoes specifications vary from the standard configuration