

Power Range	
Peak Current	8 A
Continuous Current	4 A
Supply Voltage	10 - 80 VDC



Description

The CABDC8A80X PWM servo drive is designed to drive brushless and brushed DC motors at a high switching frequency. The CABDC8A80X is fully protected against over-voltage, under-voltage, over-current, over-heating and short-circuits. A single digital output indicates operating status. The drive interfaces with digital controllers that have digital PWM output. The PWM IN duty cycle determines the output current and DIR input determines the direction of rotation.

The CABDC8A80X conforms to the following specifications and is designed to the Environmental Engineering Considerations as defined in MIL-STD-810F.

Extended Environment Performance	
Ambient Temperature	-40°C to +85°C (-40°F to +185°F)
Storage Temperature	-50°C to +100°C (-58°F to +212°F)
Thermal Shock	-40°C to +85°C (-40°F to +185°F) in 2 min.
Relative Humidity	0 to 95% Non-Condensing
Vibration	30 Grms for 5 min. in 3 axes

See Part Numbering Information on last page of datasheet for additional ordering options.

Features	
➤ High Power Density	➤ Wide Temperature Range
➤ Compact Size	➤ High Performance Thermal Dissipation
➤ Built-in regenerative and shunt regulator	➤ Differential Input Command
➤ Lightweight	➤ Current Monitor Output
➤ High Switching Frequency	➤ Digital Fault Output Monitor
➤ Four Quadrant Regenerative Operation	➤ 12VDC Operation

HARDWARE PROTECTION

- Over-Voltage
- Under-Voltage
- Over-Current
- Over-Temperature
- Short-circuit (phase-phase)
- Short-circuit (phase-ground)

INPUTS/OUTPUTS

- Digital Fault Output
- Digital Inhibit Input
- Analog Current Monitor
- Analog Command Input
- Analog Current Reference

FEEDBACK SUPPORTED

- Hall Sensors

MODES OF OPERATION

- Current

COMMUTATION

- Trapezoidal

MOTORS SUPPORTED

- Three Phase (Brushless)
- Single Phase (Brushed, Voice Coil, Inductive Load)

COMMAND SOURCE

- PWM

COMPLIANCE CONSIDERATIONS

- MIL-STD-810F (as stated)
- MIL-STD-1275D (optional)
- MIL-STD-461E (optional)
- MIL-STD-704F (optional)
- MIL-HDBK-217 (optional)

BLOCK DIAGRAM

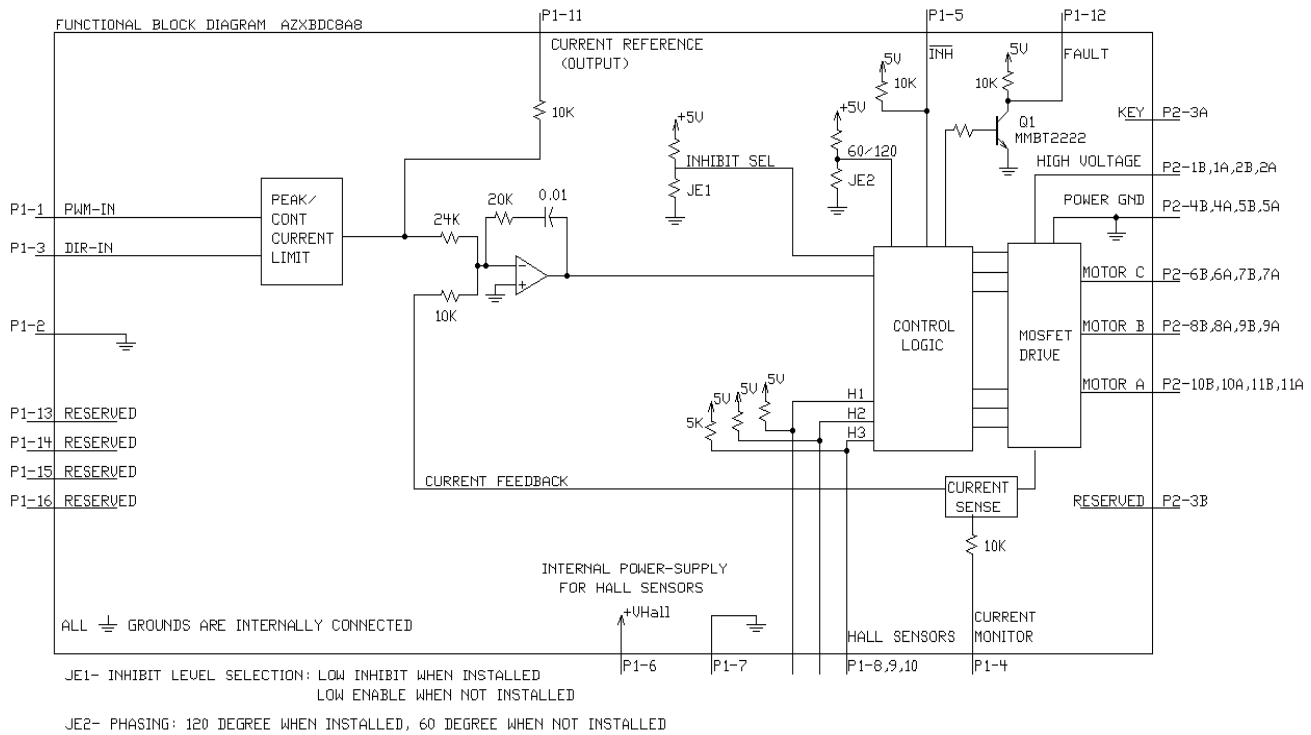

Information on Approvals and Compliances

MIL-STD-810F	Environmental Engineering Considerations and Laboratory Tests – (as stated)
MIL-STD-1275D	Characteristics of 28 Volt DC Electrical Systems in Military Vehicles – (optional)
MIL-STD-461E	Requirements for the Control of Electromagnetic Interference Characteristics of Subsystems and Equipment – (optional)
MIL-STD-704F	Aircraft Electric Power Characteristics – (optional)
MIL-HDBK-217	Reliability Prediction of Electronic Equipment (MTBF) – (optional)

HARDWARE SETTINGS

Jumper Settings

Jumpers are SMT, 0 ohm resistors located on the underside of the drive PCB. By default, the drive is configured with the jumpers installed. Typical drive operation will not require the jumpers to be removed. Please contact the factory before jumper removal.

Jumpe	Description	Configuration	
		Not Installed	Installed
JE1	Inhibit logic. Sets the logic level of inhibit pins. Labeled JE1 on the PCB of the drive.	Low Enable	Low Inhibit
JE2	Hall sensor phasing. Selects 120 or 60 degree commutation phasing. Labeled JE2 on the PCB of the drive.	60 degree	120 degree

Notes:

Any damage done to the drive while performing these modifications will void the product warranty. It is recommended to contact AMC China's technical staff before setting of JPE1 and JPE2.

SPECIFICATIONS

Description	Power Specifications		Value
	Units		
DC Supply Voltage Range	VDC	10 - 80	
DC Bus Over Voltage Limit	VDV	88	
DC Bus Under Voltage Limit	VDC	9	
Maximum Peak Output Current ¹	A	8	
Maximum Continuous Output Current	A	4	
Maximum Continuous Output Power	W	304	
Maximum Power Dissipation at Continuous Current	W	16	
Minimum Load Inductance (Line-To-Line) ²	µH	100	
Internal Bus Capacitance ³	µF	320	
Low Voltage Supply Outputs	-	+6 VDC (30 mA)	
Switching Frequency	kHz	31	
Description	Control Specifications		Value
	Units		
Command Sources	-	PWM	
PWM Input Frequency Range	kHz	10-25	
Feedback Supported	-	Halls	
Commutation Methods	-	Trapezoidal	
Modes of Operation	-	Current	
Motors Supported	-	Single Phase (Brushed, Voice Coil, Inductive Load), Three Phase (Brushless)	
Hardware Protection	-	Invalid Commutation Feedback, Over Current, Over Temperature, Over Voltage, Under Voltage, Short Circuit (Phase-Phase & Phase-Ground)	
Description	Mechanical Specifications		Value
	Units		
Agency Approvals	-	RoHS, MIL-STD-810F (as stated), MIL-STD-1275D (optional), MIL-STD-461E (optional), MIL-STD-704F (optional), MIL-HDBK-217 (optional)	
Size (H x W x D)	mm	127 x 77.5 x 44.5	
Baseplate Operating Temperature Range	°C (°F)	-40 - 105 (-40 - 221)	
Ambient Temperature Range	°C (°F)	-40 - 85 (-40 - 185)	
Storage Temperature Range	°C (°F)	-50 - 100 (-58 - 212)	
Thermal Shock	°C (°F)	-40 - 85 (-40 - 185) in 2 minutes	
Vibration	Grms	30 for 5 minutes in 3 axes	
Relative Humidity	-	0 - 95% Non-Condensing	
P1 Connector	-	16 Pin, pitch 2.54 mm connector	
P2 Connector	-	8Pin pitch 5.08 mm Pluggable terminal block	

Notes

1. Maximum duration of peak current is ~2 seconds. Peak RMS value must not exceed continuous current rating of the drive.
2. Lower inductance is acceptable for bus voltages well below maximum. If the motor inductance is lower than the minimum inductance, please contact the factory for customized modification.

PIN FUNCTIONS

P1 Signal Interface Definitions		
Connector information		16 Pin, pitch 2.54 mm connector
Matching Connector	Part No.	Molex: P/N 22-01-3167 (Housings) and P/N 08-50-0114 (CRIMP TERMINAL)
	Remark	Connectors need to be ordered separately
Pin	Signal	Description
1	PWM / IN	10 – 25 kHz pulse width modulated digital input command (+5V). Input duty cycle commands the output current.
2	SIGNAL GND	Signal Ground
3	DIRECTION	Direction Input (+5 V)
4	CURRENT MONITOR	Current Monitor. Analog output signal proportional to the actual current output. Polarity is reversed from command voltage. Scaling is 2.7 A/V. Measure relative to signal ground.
5	INHIBIT IN	TTL level (+5 V) inhibit/enable input. Leave open to enable drive. Pull to ground to inhibit drive. Inhibit turns off all power devices.
6	+V HALL OUT	Low Power Supply For Hall Sensors (+6 V @ 30 mA). Referenced to signal ground. Short circuit protected.
7	SIGNAL GND	Signal Ground
8	HALL 1	Single-ended Hall/Commutation Sensor Inputs (+5 V logic level)
9	HALL 2 ¹	
10	HALL 3	
11	CURRENT REFERENCE	Measures the command signal to the internal current-loop. This pin has a maximum output of ± 7.3 V when the drive outputs maximum peak current. Measure relative to signal ground.
12	FAULT OUT	TTL level (+5 V) output becomes high when power devices are disabled due to at least one of the following conditions: inhibit, invalid Hall state, output short circuit, over voltage, over temperature, power-up reset.
13	RESERVED	RESERVED
14	RESERVED	
15	RESERVED	
16	RESERVED	

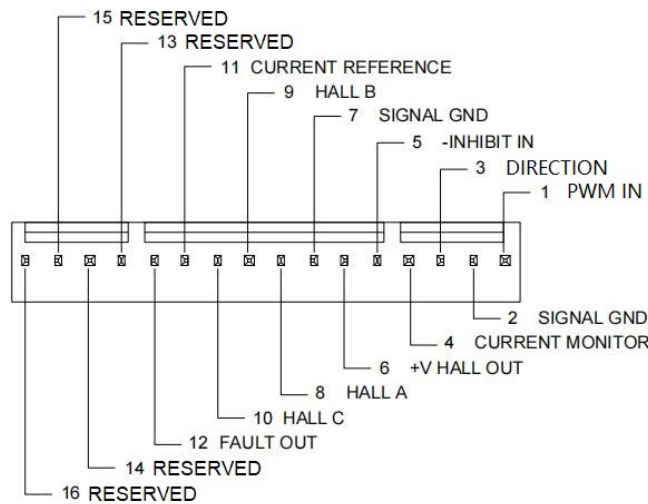

1. For use with Single Phase (Brushed) motors, ground Hall 2 and only connect motor leads to Motor A and Motor B.

P2 Power Interface Definitions		
Connector information		8Pin pitch 5.08 mm Pluggable terminal block
Matching Connector	Part No.	KF2EDGK5.08
	Remark	Connectors need to be ordered separately
Pin	Signal	Description
1	HV	DC+ Power Input
2	GND	Power Ground (Common With Signal Ground).
3	PE	Protective ground (Connect motor cable shield)
4	MC	Motor Phase W
5	MB	Motor Phase V
6	MA	Motor Phase U
7	HV/BR+	External braking resistor connection. Connect a resistor between BR+ and BR-.
8	BR-	

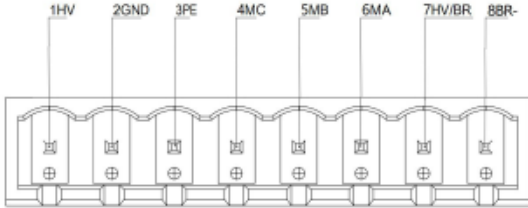

Golden Ding Series Analog Servo Drives



DIMENSIONS (mm)

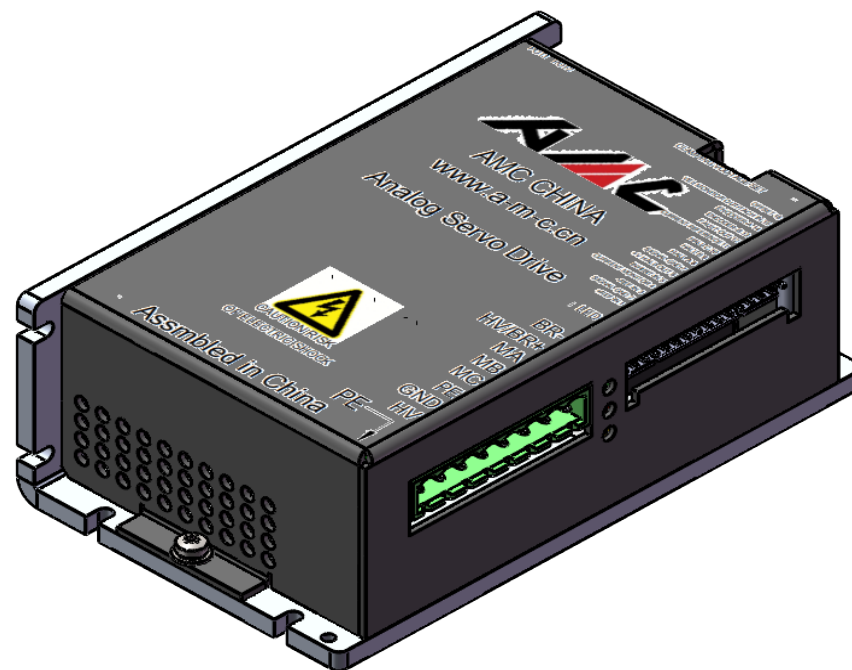
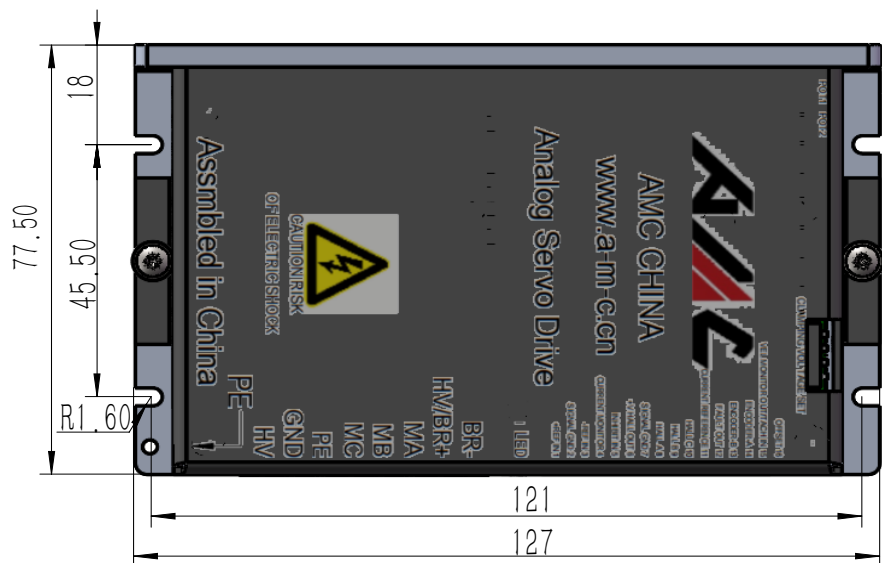
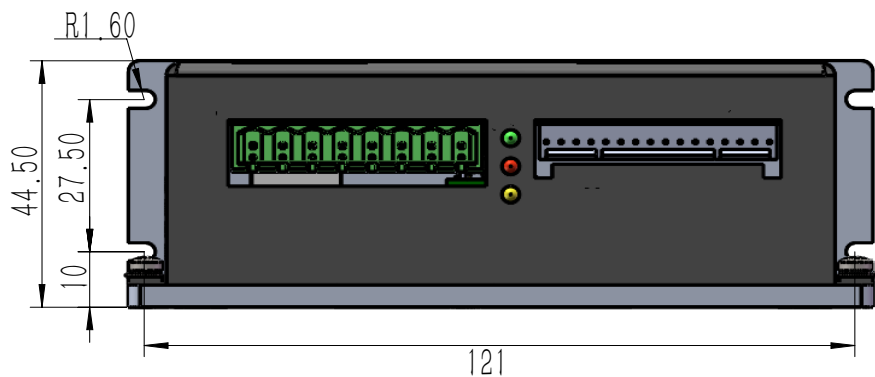

PART NUMBERING INFORMATION

